

High Voltage, High-Side Current Sense Amplifier in SOT-23

FEATURES

- **Supply Range:**
5V to 100V, 105V Absolute Maximum (LTC6101HV)
4V to 60V, 70V Absolute Maximum (LTC6101)
- **Low Offset Voltage: 300µV Max**
- **Fast Response: 1µs Response Time (0V to 2.5V on a 5V Output Step)**
- **Gain Configurable with 2 Resistors**
- Low Input Bias Current: 170nA Max
- PSRR: 118dB Min
- Output Current: 1mA Max
- Low Supply Current: 250µA, $V_S = 12V$
- Specified Temperature Range: $-40^{\circ}C$ to $125^{\circ}C$
- Operating Temperature Range: $-55^{\circ}C$ to $125^{\circ}C$
- Package Option for High Voltage Spacing
- Low Profile (1mm) SOT-23 (ThinSOT™) Package

APPLICATIONS

- Current Shunt Measurement
- Battery Monitoring
- Remote Sensing
- Power Management

All registered trademarks and trademarks are the property of their respective owners.

DESCRIPTION

The LTC®6101/LTC6101HV are versatile, high voltage, high side current sense amplifiers. Design flexibility is provided by the excellent device characteristics; 300µV Max offset and only 375µA (typical at 60V) of current consumption. The LTC6101 operates on supplies from 4V to 60V and LTC6101HV operates on supplies from 5V to 100V.

The LTC6101 monitors current via the voltage across an external sense resistor (shunt resistor). Internal circuitry converts input voltage to output current, allowing for a small sense signal on a high common mode voltage to be translated into a ground referenced signal. Low DC offset allows the use of a small shunt resistor and large gain-setting resistors. As a result, power loss in the shunt is reduced.

The wide operating supply range and high accuracy make the LTC6101 ideal for a large array of applications from automotive to industrial and power management. A maximum input sense voltage of 500mV allows a wide range of currents to be monitored. The fast response makes the LTC6101 the perfect choice for load current warnings and shutoff protection control. With very low supply current, the LTC6101 is suitable for power sensitive applications.

The LTC6101 is available in 5-lead SOT-23 and 8-lead MSOP packages.

TYPICAL APPLICATION

16-Bit Resolution Unidirectional Output into LTC2433 ADC

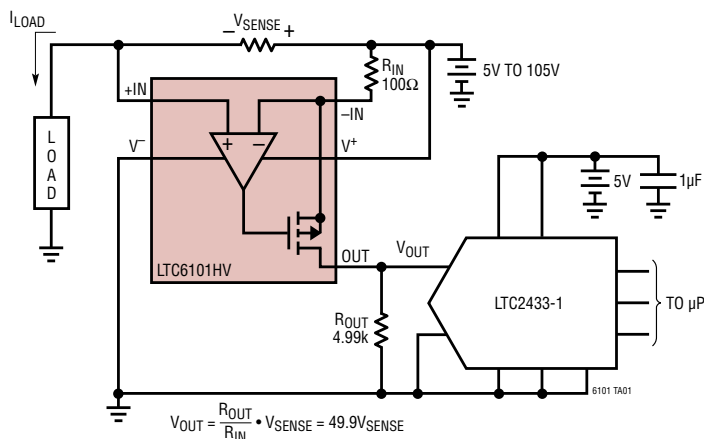

Step Response

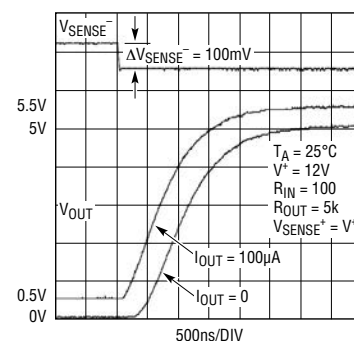

6101 TA01b

LTC6101HV

ABSOLUTE MAXIMUM RATINGS

(Note 1)

| | | | | | | |
|---|---------------------|-------|----------------|--------------------------------------|-------|----------------|
| Total Supply Voltage (V^+ to V^-) | LTC6101/LTC6101HV | | 70V / 105V | LTC6101I/LTC6101HVI | | -40°C to 85°C |
| Minimum Input Voltage ($-IN$ Pin) | LTC6101/LTC6101HV | | ($V^+ - 4V$) | LTC6101H/LTC6101HVH | | -55°C to 125°C |
| Maximum Output Voltage (Out Pin) | LTC6101/LTC6101HV | | 9V | Specified Temperature Range (Note 2) | | |
| Input Current | LTC6101/LTC6101HV | | $\pm 10mA$ | LTC6101C/LTC6101HVC | | 0°C to 70°C |
| Output Short-Circuit Duration (to V^-) | LTC6101/LTC6101HV | | Indefinite | LTC6101I/LTC6101HVI | | -40°C to 85°C |
| Operating Temperature Range | LTC6101/LTC6101HV | | -40°C to 85°C | LTC6101H/LTC6101HVH | | -40°C to 125°C |
| | LTC6101C/LTC6101HVC | | -40°C to 85°C | Storage Temperature Range | | -65°C to 150°C |
| | | | | Lead Temperature (Soldering, 10 sec) | | 300°C |

PIN CONFIGURATION

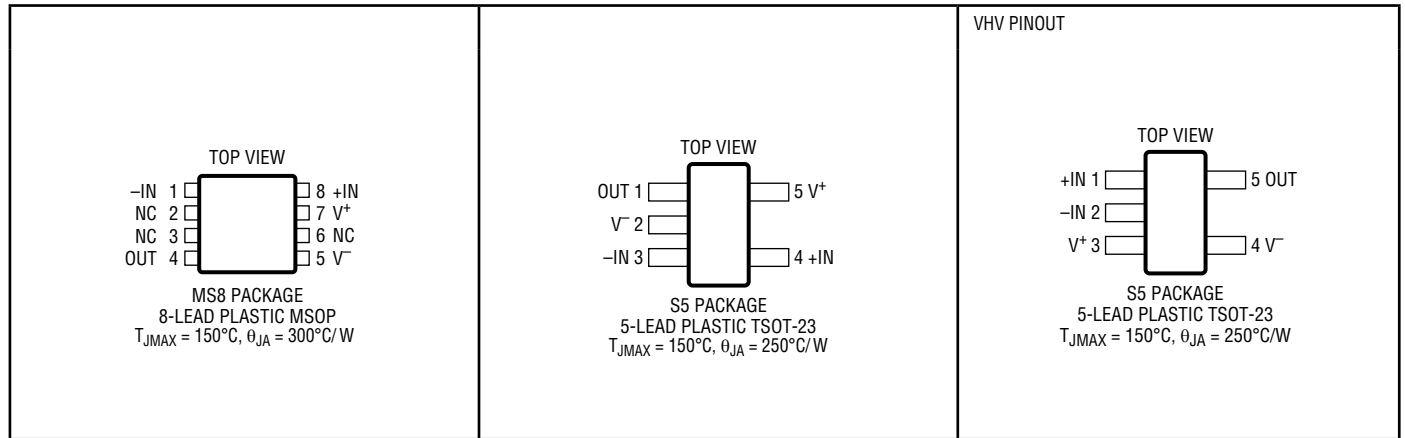

ORDER INFORMATION

<http://www.linear.com/product/LTC6101#orderinfo>

| LEAD FREE FINISH | TAPE AND REEL | PART MARKING* | PACKAGE DESCRIPTION | SPECIFIED TEMPERATURE RANGE |
|--------------------|----------------------|---------------|---------------------|-----------------------------|
| LTC6101ACMS8#PBF | LTC6101ACMS8#TRPBF | LTBSB | 8-Lead Plastic MSOP | 0°C to 70°C |
| LTC6101AIMS8#PBF | LTC6101AIMS8#TRPBF | LTBSB | 8-Lead Plastic MSOP | -40°C to 85°C |
| LTC6101AHMS8#PBF | LTC6101AHMS8#TRPBF | LTBSB | 8-Lead Plastic MSOP | -40°C to 125°C |
| LTC6101HVACMS8#PBF | LTC6101HVACMS8#TRPBF | LTBSX | 8-Lead Plastic MSOP | 0°C to 70°C |
| LTC6101HVAIMS8#PBF | LTC6101HVAIMS8#TRPBF | LTBSX | 8-Lead Plastic MSOP | -40°C to 85°C |
| LTC6101HVAHMS8#PBF | LTC6101HVAHMS8#TRPBF | LTBSX | 8-Lead Plastic MSOP | -40°C to 125°C |

ORDER INFORMATION

Lead Free Finish

| TAPE AND REEL (MINI) | TAPE AND REEL | PART MARKING* | PACKAGE DESCRIPTION | SPECIFIED TEMPERATURE RANGE |
|-----------------------|----------------------|---------------|----------------------------------|-----------------------------|
| LTC6101ACS5#TRMPBF | LTC6101ACS5#TRPBF | LTBND | 5-Lead Plastic TSOT-23 | 0°C to 70°C |
| LTC6101AIS5#TRMPBF | LTC6101AIS5#TRPBF | LTBND | 5-Lead Plastic TSOT-23 | -40°C to 85°C |
| LTC6101AHS5#TRMPBF | LTC6101AHS5#TRPBF | LTBND | 5-Lead Plastic TSOT-23 | -40°C to 125°C |
| LTC6101BCS5#TRMPBF | LTC6101BCS5#TRPBF | LTBND | 5-Lead Plastic TSOT-23 | 0°C to 70°C |
| LTC6101BIS5#TRMPBF | LTC6101BIS5#TRPBF | LTBND | 5-Lead Plastic TSOT-23 | -40°C to 85°C |
| LTC6101BHS5#TRMPBF | LTC6101BHS5#TRPBF | LTBND | 5-Lead Plastic TSOT-23 | -40°C to 125°C |
| LTC6101CCS5#TRMPBF | LTC6101CCS5#TRPBF | LTBND | 5-Lead Plastic TSOT-23 | 0°C to 70°C |
| LTC6101CIS5#TRMPBF | LTC6101CIS5#TRPBF | LTBND | 5-Lead Plastic TSOT-23 | -40°C to 85°C |
| LTC6101CHS5#TRMPBF | LTC6101CHS5#TRPBF | LTBND | 5-Lead Plastic TSOT-23 | -40°C to 125°C |
| LTC6101HVACS5#TRMPBF | LTC6101HVACS5#TRPBF | LTBSZ | 5-Lead Plastic TSOT-23 | 0°C to 70°C |
| LTC6101HVAIS5#TRMPBF | LTC6101HVAIS5#TRPBF | LTBSZ | 5-Lead Plastic TSOT-23 | -40°C to 85°C |
| LTC6101HVAHS5#TRMPBF | LTC6101HVAHS5#TRPBF | LTBSZ | 5-Lead Plastic TSOT-23 | -40°C to 125°C |
| LTC6101HVBCS5#TRMPBF | LTC6101HVBCS5#TRPBF | LTBSZ | 5-Lead Plastic TSOT-23 | 0°C to 70°C |
| LTC6101HVBIS5#TRMPBF | LTC6101HVBIS5#TRPBF | LTBSZ | 5-Lead Plastic TSOT-23 | -40°C to 85°C |
| LTC6101HVBHS5#TRMPBF | LTC6101HVBHS5#TRPBF | LTBSZ | 5-Lead Plastic TSOT-23 | -40°C to 125°C |
| LTC6101HVCCS5#TRMPBF | LTC6101HVCCS5#TRPBF | LTBSZ | 5-Lead Plastic TSOT-23 | 0°C to 70°C |
| LTC6101HVCIS5#TRMPBF | LTC6101HVCIS5#TRPBF | LTBSZ | 5-Lead Plastic TSOT-23 | -40°C to 85°C |
| LTC6101HVCHS5#TRMPBF | LTC6101HVCHS5#TRPBF | LTBSZ | 5-Lead Plastic TSOT-23 | -40°C to 125°C |
| LTC6101VHVACS5#TRMPBF | LTC6101VHVACS5#TRPBF | LTHHD | 5-Lead Plastic TSOT-23 HV Pinout | 0°C to 70°C |
| LTC6101VHVAIS5#TRMPBF | LTC6101VHVAIS5#TRPBF | LTHHD | 5-Lead Plastic TSOT-23 HV Pinout | -40°C to 85°C |
| LTC6101VHVAHS5#TRMPBF | LTC6101VHVAHS5#TRPBF | LTHHD | 5-Lead Plastic TSOT-23 HV Pinout | -40°C to 125°C |
| LTC6101VHVBCS5#TRMPBF | LTC6101VHVBCS5#TRPBF | LTHHD | 5-Lead Plastic TSOT-23 HV Pinout | 0°C to 70°C |
| LTC6101VHVBIS5#TRMPBF | LTC6101VHVBIS5#TRPBF | LTHHD | 5-Lead Plastic TSOT-23 HV Pinout | -40°C to 85°C |
| LTC6101VHVBHS5#TRMPBF | LTC6101VHVBHS5#TRPBF | LTHHD | 5-Lead Plastic TSOT-23 HV Pinout | -40°C to 125°C |
| LTC6101VHVCCS5#TRMPBF | LTC6101VHVCCS5#TRPBF | LTHHD | 5-Lead Plastic TSOT-23 HV Pinout | 0°C to 70°C |
| LTC6101VHVCIS5#TRMPBF | LTC6101VHVCIS5#TRPBF | LTHHD | 5-Lead Plastic TSOT-23 HV Pinout | -40°C to 85°C |
| LTC6101VHVCHS5#TRMPBF | LTC6101VHVCHS5#TRPBF | LTHHD | 5-Lead Plastic TSOT-23 HV Pinout | -40°C to 125°C |

TRM = 500 pieces. *Temperature grades are identified by a label on the shipping container.

Consult ADI Marketing for parts specified with wider operating temperature ranges.

Consult ADI Marketing for information on lead based finish parts.

For more information on lead free part marking, go to: <http://www.linear.com/leadfree/>

For more information on tape and reel specifications, go to: <http://www.linear.com/tapeand reel/>

LTC6101HV

ELECTRICAL CHARACTERISTICS (LTC6101) The ● denotes the specifications which apply over the full specified temperature range, otherwise specifications are at $T_A = 25^\circ\text{C}$, $R_{IN} = 100\Omega$, $R_{OUT} = 10k$, $V_{SENSE}^+ = V^+$ (see Figure 1 for details), $4V \leq V_S \leq 60V$ unless otherwise noted.

| SYMBOL | PARAMETER | CONDITIONS | MIN | TYP | MAX | UNITS | |
|--------------------------|--|---|-----|-----|---------------|---------------|------------------------------|
| V_S | Supply Voltage Range | | ● | 4 | 60 | V | |
| V_{OS} | Input Offset Voltage | $V_{SENSE} = 5\text{mV}$, Gain = 100, LTC6101A | ● | | ± 85 | ± 300 | μV |
| | | $V_{SENSE} = 5\text{mV}$, Gain = 100, LTC6101AC, LTC6101AI | ● | | | ± 450 | μV |
| | | $V_{SENSE} = 5\text{mV}$, Gain = 100, LTC6101AH | ● | | | ± 535 | μV |
| | | $V_{SENSE} = 5\text{mV}$, Gain = 100, LTC6101B | ● | | ± 150 | ± 450 | μV |
| | | $V_{SENSE} = 5\text{mV}$, Gain = 100, LTC6101C | ● | | ± 400 | 800 | μV |
| | | | | | 1200 | μV | |
| $\Delta V_{OS}/\Delta T$ | Input Offset Voltage Drift | $V_{SENSE} = 5\text{mV}$, LTC6101A | ● | | ± 1 | | $\mu\text{V}/^\circ\text{C}$ |
| | | $V_{SENSE} = 5\text{mV}$, LTC6101B | ● | | ± 3 | | $\mu\text{V}/^\circ\text{C}$ |
| | | $V_{SENSE} = 5\text{mV}$, LTC6101C | ● | | ± 5 | | $\mu\text{V}/^\circ\text{C}$ |
| I_B | Input Bias Current | $R_{IN} = 1\text{M}$ | ● | | 100 | 170 | nA |
| | | | ● | | | 245 | nA |
| I_{OS} | Input Offset Current | $R_{IN} = 1\text{M}$ | ● | | ± 2 | ± 15 | nA |
| $V_{SENSE(MAX)}$ | Input Sense Voltage Full Scale | V_{OS} within Specification, $R_{IN} = 1k$ (Note 3) | ● | 500 | | | mV |
| PSRR | Power Supply Rejection Ratio | $V_S = 6V$ to $60V$, $V_{SENSE} = 5\text{mV}$, Gain = 100 | ● | 118 | 140 | | dB |
| | | | ● | 115 | | | dB |
| | | $V_S = 4V$ to $60V$, $V_{SENSE} = 5\text{mV}$, Gain = 100 | ● | 110 | 133 | | dB |
| | | | ● | 105 | | | dB |
| V_{OUT} | Maximum Output Voltage | $12V \leq V_S \leq 60V$, $V_{SENSE} = 88\text{mV}$ | ● | 8 | | | V |
| | | $V_S = 6V$, $V_{SENSE} = 330\text{mV}$, $R_{IN} = 1k$, $R_{OUT} = 10k$ | ● | 3 | | | V |
| | | $V_S = 4V$, $V_{SENSE} = 550\text{mV}$, $R_{IN} = 1k$, $R_{OUT} = 2k$ | ● | 1 | | | V |
| $V_{OUT(0)}$ | Minimum Output Voltage | $V_{SENSE} = 0V$, Gain = 100, LTC6101A | ● | | 0 | 30 | mV |
| | | $V_{SENSE} = 0V$, Gain = 100, LTC6101AC, LTC6101AI | ● | | | 45 | mV |
| | | $V_{SENSE} = 0V$, Gain = 100, LTC6101AH | ● | | | 53.5 | mV |
| | | $V_{SENSE} = 0V$, Gain = 100, LTC6101B | ● | | 0 | 45 | mV |
| | | | ● | | | 81 | mV |
| | | $V_{SENSE} = 0V$, Gain = 100, LTC6101C | ● | | 0 | 150 | mV |
| | | | ● | | | 250 | mV |
| I_{OUT} | Maximum Output Current | $6V \leq V_S \leq 60V$, $R_{OUT} = 2k$, $V_{SENSE} = 110\text{mV}$, Gain = 20 | ● | 1 | | | mA |
| | | $V_S = 4V$, $V_{SENSE} = 550\text{mV}$, Gain = 2, $R_{OUT} = 2k$ | ● | 0.5 | | | mA |
| t_r | Input Step Response (to 2.5V on a 5V Output Step) | $\Delta V_{SENSE} = 100\text{mV}$ Transient, $6V \leq V_S \leq 60V$, Gain = 50 | | | 1 | | μs |
| | | $V_S = 4V$ | | | 1.5 | | μs |
| BW | Signal Bandwidth | $I_{OUT} = 200\mu\text{A}$, $R_{IN} = 100$, $R_{OUT} = 5k$ | | | 140 | | kHz |
| | | $I_{OUT} = 1\text{mA}$, $R_{IN} = 100$, $R_{OUT} = 5k$ | | | 200 | | kHz |
| I_S | Supply Current | $V_S = 4V$, $I_{OUT} = 0$, $R_{IN} = 1\text{M}$ | ● | | 220 | 450 | μA |
| | | | | | | 475 | μA |
| | | $V_S = 6V$, $I_{OUT} = 0$, $R_{IN} = 1\text{M}$ | ● | | 240 | 475 | μA |
| | | | ● | | | 525 | μA |
| | | $V_S = 12V$, $I_{OUT} = 0$, $R_{IN} = 1\text{M}$ | ● | | 250 | 500 | μA |
| | ● | | | 590 | μA | | |
| | | $V_S = 60V$, $I_{OUT} = 0$, $R_{IN} = 1\text{M}$ LTC6101AI, LTC6101AC, LTC6101BI, LTC6101BC, LTC6101CI, LTC6101CC | ● | | 375 | 640 | μA |
| | | LTC6101AH, LTC6101BH, LTC6101CH | ● | | | 690 | μA |
| | | | ● | | | 720 | μA |

ELECTRICAL CHARACTERISTICS (LTC6101HV) The ● denotes the specifications which apply over the full specified temperature range, otherwise specifications are at $T_A = 25^\circ\text{C}$, $R_{IN} = 100\Omega$, $R_{OUT} = 10k$, $V_{SENSE}^+ = V^+$ (see Figure 1 for details), $5V \leq V_S \leq 100V$ unless otherwise noted.

| SYMBOL | PARAMETER | CONDITIONS | MIN | TYP | MAX | UNITS | |
|--------------------------|--|---|-----|-----|-----------|-----------|------------------|
| V_S | Supply Voltage Range | | ● | 5 | 100 | V | |
| V_{OS} | Input Offset Voltage | $V_{SENSE} = 5mV$, Gain = 100, LTC6101HVA | ● | | ± 85 | ± 300 | μV |
| | | $V_{SENSE} = 5mV$, Gain = 100, LTC6101HVAC, LTC6101HVAI | ● | | | ± 450 | μV |
| | | $V_{SENSE} = 5mV$, Gain = 100, LTC6101HVAH | ● | | | ± 535 | μV |
| | | $V_{SENSE} = 5mV$, Gain = 100, LTC6101HVB | ● | | ± 150 | ± 450 | μV |
| | | | | | | ± 810 | μV |
| | | $V_{SENSE} = 5mV$, Gain = 100, LTC6101HVC | ● | | ± 400 | 800 | μV |
| | | | | | 1200 | μV | |
| $\Delta V_{OS}/\Delta T$ | Input Offset Voltage Drift | $V_{SENSE} = 5mV$, LTC6101HVA | ● | | ± 1 | | $\mu V/^\circ C$ |
| | | $V_{SENSE} = 5mV$, LTC6101HVB | ● | | ± 3 | | $\mu V/^\circ C$ |
| | | $V_{SENSE} = 5mV$, LTC6101HVC | ● | | ± 5 | | $\mu V/^\circ C$ |
| I_B | Input Bias Current | $R_{IN} = 1M$ | ● | | 100 | 170 | nA |
| | | | | | | 245 | nA |
| I_{OS} | Input Offset Current | $R_{IN} = 1M$ | ● | | ± 2 | ± 15 | nA |
| $V_{SENSE(MAX)}$ | Input Sense Voltage Full Scale | V_{OS} within Specification, $R_{IN} = 1k$ (Note 3) | ● | 500 | | | mV |
| PSRR | Power Supply Rejection Ratio | $V_S = 6V$ to 100V, $V_{SENSE} = 5mV$, Gain = 100 | ● | 118 | 140 | | dB |
| | | | | 115 | | | dB |
| | | $V_S = 5V$ to 100V, $V_{SENSE} = 5mV$, Gain = 100 | ● | 110 | 133 | | dB |
| | | | | 105 | | | dB |
| V_{OUT} | Maximum Output Voltage | $12V \leq V_S \leq 100V$, $V_{SENSE} = 88mV$ | ● | 8 | | | V |
| | | $V_S = 5V$, $V_{SENSE} = 330mV$, $R_{IN} = 1k$, $R_{OUT} = 10k$ | ● | 3 | | | V |
| $V_{OUT(0)}$ | Minimum Output Voltage | $V_{SENSE} = 0V$, Gain = 100, LTC6101HVA | ● | | 0 | 30 | mV |
| | | $V_{SENSE} = 0V$, Gain = 100, LTC6101HVAC, LTC6101HVAI | ● | | | 45 | mV |
| | | $V_{SENSE} = 0V$, Gain = 100, LTC6101HVAH | ● | | | 53.5 | mV |
| | | $V_{SENSE} = 0V$, Gain = 100, LTC6101HVB | ● | | 0 | 45 | mV |
| | | | | | 81 | mV | |
| | | $V_{SENSE} = 0V$, Gain = 100, LTC6101HVC | ● | | 0 | 150 | mV |
| | | | | | 250 | mV | |
| I_{OUT} | Maximum Output Current | $5V \leq V_S \leq 100V$, $R_{OUT} = 2k$, $V_{SENSE} = 110mV$, Gain = 20 | ● | 1 | | | mA |
| t_r | Input Step Response (to 2.5V on a 5V Output Step) | $\Delta V_{SENSE} = 100mV$ Transient, $6V \leq V_S \leq 100V$, Gain = 50 | | | 1 | | μs |
| | | $V_S = 5V$ | | | 1.5 | | μs |
| BW | Signal Bandwidth | $I_{OUT} = 200\mu A$, $R_{IN} = 100$, $R_{OUT} = 5k$ | | | 140 | | kHz |
| | | $I_{OUT} = 1mA$, $R_{IN} = 100$, $R_{OUT} = 5k$ | | | 200 | | kHz |
| I_S | Supply Current | $V_S = 5V$, $I_{OUT} = 0$, $R_{IN} = 1M$ | ● | | 200 | 450 | μA |
| | | | | | | 475 | μA |
| | | $V_S = 6V$, $I_{OUT} = 0$, $R_{IN} = 1M$ | ● | | 220 | 475 | μA |
| | | | | | | 525 | μA |
| | | $V_S = 12V$, $I_{OUT} = 0$, $R_{IN} = 1M$ | ● | | 230 | 500 | μA |
| | | | | | | 590 | μA |
| | | $V_S = 60V$, $I_{OUT} = 0$, $R_{IN} = 1M$ LTC6101HVI, LTC6101HVC | ● | | 350 | 640 | μA |
| | | LTC6101HVH | ● | | | 690 | μA |
| | | | | | | 720 | μA |
| | | $V_S = 100V$, $I_{OUT} = 0$, $R_{IN} = 1M$ LTC6101HVAI, LTC6101HVAC, LTC6101HVBI, LTC6101HVBC, LTC6101HVCI, LTC6101HVCC | ● | | 350 | 640 | μA |
| | | LTC6101HVAH, LTC6101HVBH, LTC6101HVCH | ● | | | 690 | μA |
| | | | | | | 720 | μA |

LTC6101HV

ELECTRICAL CHARACTERISTICS

Note 1: Stresses beyond those listed under Absolute Maximum Ratings may cause permanent damage to the device. Exposure to any Absolute Maximum Rating condition for extended periods may affect device reliability and lifetime.

Note 2: The LTC6101C/LTC6101HVC are guaranteed to meet specified performance from 0°C to 70°C. The LTC6101C/LTC6101HVC are designed,

characterized and expected to meet specified performance from -40°C to 85°C but are not tested or QA sampled at these temperatures. LTC6101I/LTC6101HVI are guaranteed to meet specified performance from -40°C to 85°C. The LTC6101H/LTC6101HVH are guaranteed to meet specified performance from -40°C to 125°C.

Note 3: $R_{OUT} = 10k$ for $6V \leq V_S \leq 100V$, $R_{OUT} = 2k$ for $V_S = 4V$.

TYPICAL PERFORMANCE CHARACTERISTICS

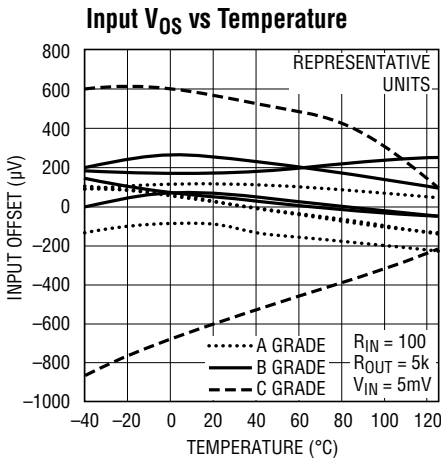

6101 G01

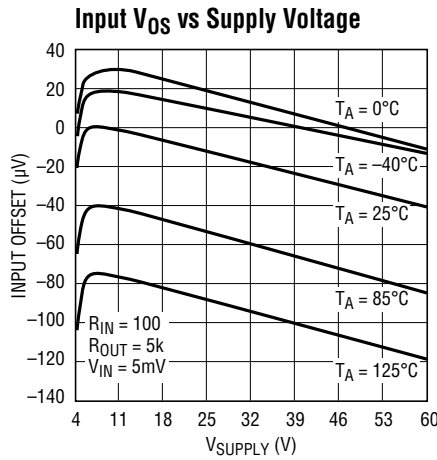

6101 G02

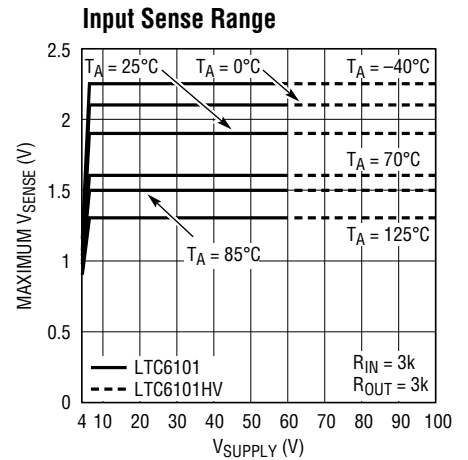

6101 G05

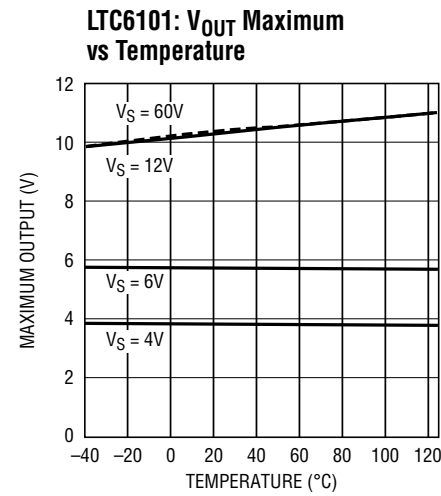

6101 G06

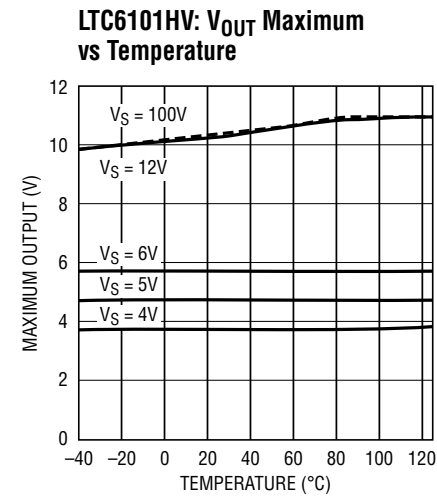

6101 G20

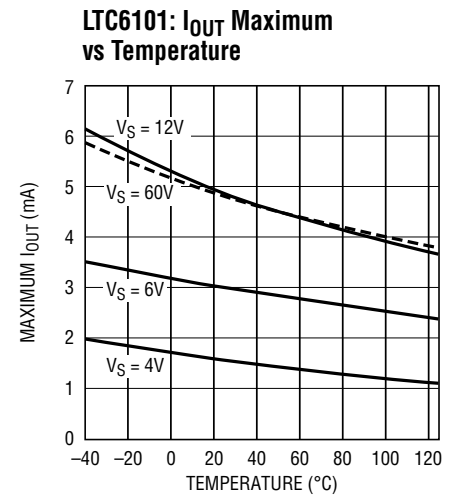

6101 G07

TYPICAL PERFORMANCE CHARACTERISTICS

LTC6101HV: I_{OUT} Maximum vs Temperature

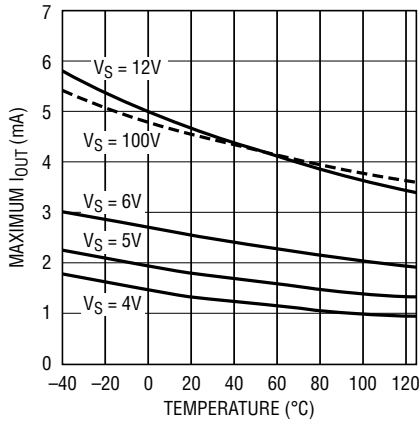

6101 G21

Output Error Due to Input Offset vs Input Voltage

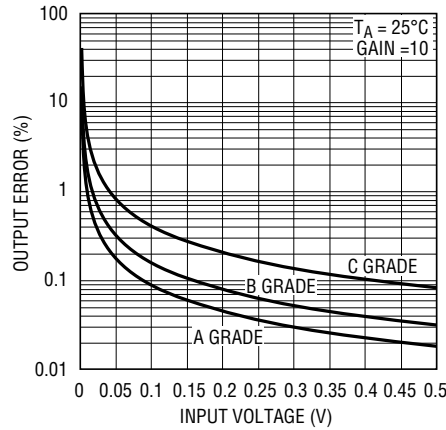

6101 G08

Gain vs Frequency

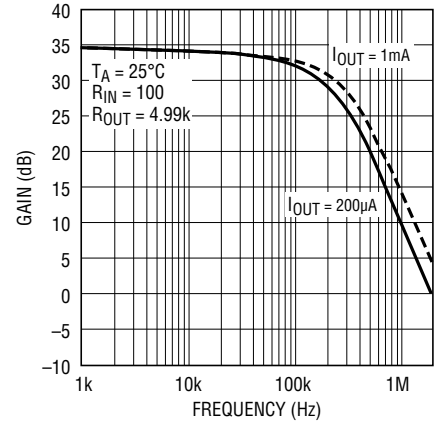

6101 G09

Input Bias Current vs Temperature

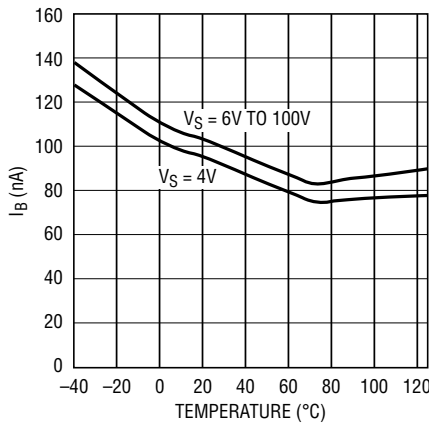

6101 G10

LTC6101: Supply Current vs Supply Voltage

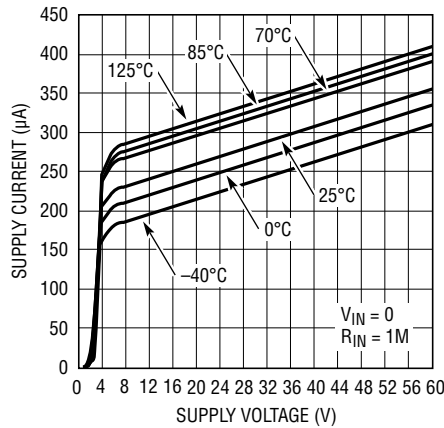

6101 G11

LTC6101HV: Supply Current vs Supply Voltage

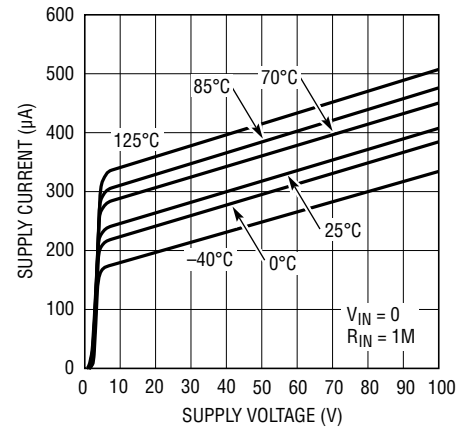

6101 G22

Step Response 0mV to 10mV

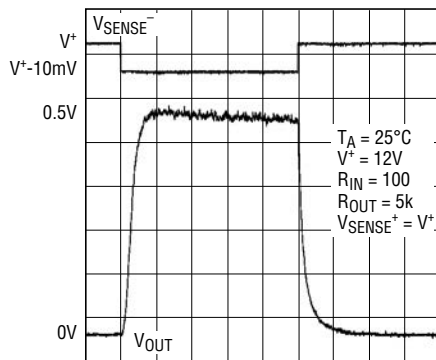

TIME (10µs/DIV)

6101 G12

Step Response 10mV to 20mV

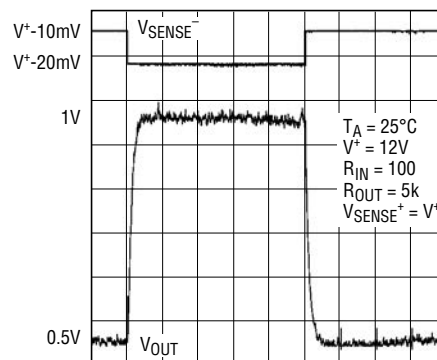

TIME (10µs/DIV)

6101 G13

TYPICAL PERFORMANCE CHARACTERISTICS

Step Response 100mV

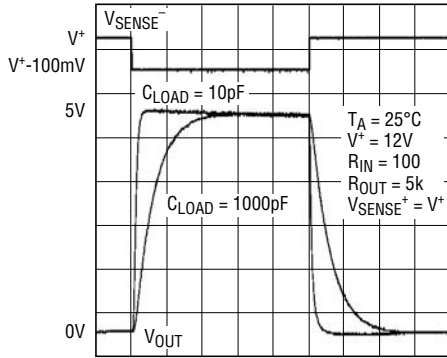

TIME (10 μ s/DIV)

6101 G14

Step Response 100mV

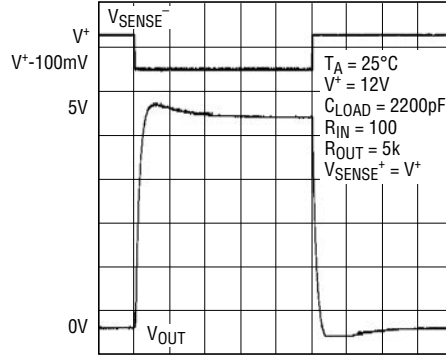

TIME (100 μ s/DIV)

6101 G15

Step Response Rising Edge

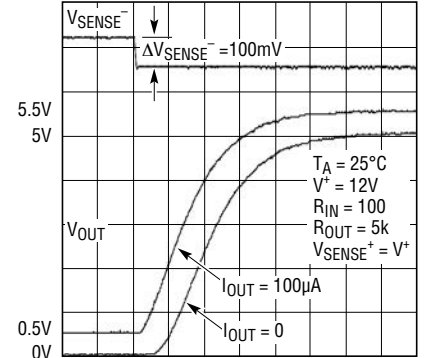

TIME (500ns/DIV)

6101 G16

Step Response Falling Edge

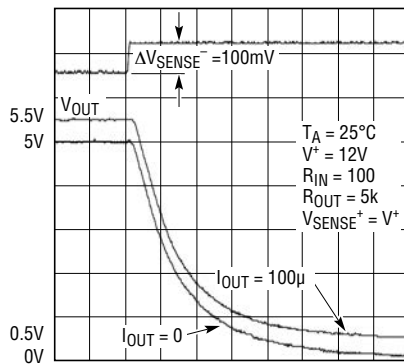

TIME (500ns/DIV)

6101 G17

PSRR vs Frequency

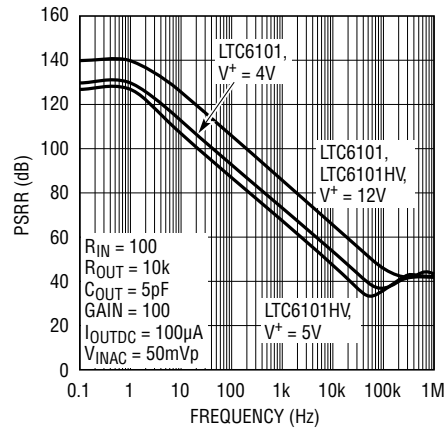

6101 G19

PIN FUNCTIONS

OUT: Current Output. OUT will source a current that is proportional to the sense voltage into an external resistor.

V⁻: Negative Supply (or Ground for Single-Supply Operation).

-IN: The internal sense amplifier will drive IN⁻ to the same potential as IN⁺. A resistor (R_{IN}) tied from V⁺ to IN⁻ sets the output current $I_{OUT} = V_{SENSE}/R_{IN}$. V_{SENSE} is the voltage developed across the external R_{SENSE} (Figure 1).

+IN: Must be tied to the system load end of the sense resistor, either directly or through a resistor.

V⁺: Positive Supply Pin. Supply current is drawn through this pin. **The circuit may be configured so that the LTC6101 supply current is or is not monitored along with the system load current.** To monitor only system load current, connect V⁺ to the more positive side of the sense resistor. To monitor the total current, including the LTC6101 current, connect V⁺ to the more negative side of the sense resistor.

BLOCK DIAGRAM

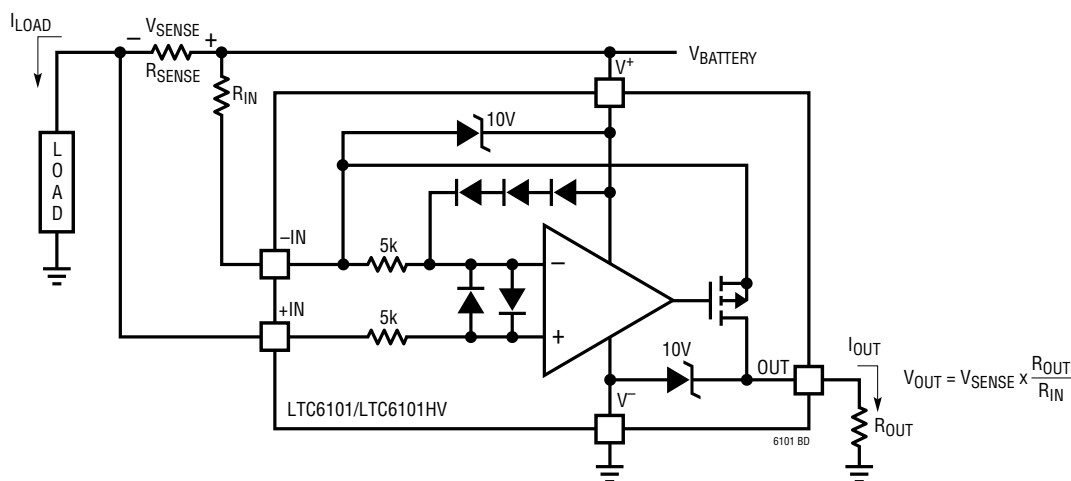

Figure 1. LTC6101/LTC6101HV Block Diagram and Typical Connection

APPLICATIONS INFORMATION

The LTC6101 high side current sense amplifier (Figure 1) provides accurate monitoring of current through a user-selected sense resistor. The sense voltage is amplified by a user-selected gain and level shifted from the positive power supply to a ground-referred output. The output signal is analog and may be used as is or processed with an output filter.

Theory of Operation

An internal sense amplifier loop forces IN⁻ to have the same potential as IN⁺. Connecting an external resis-

tor, R_{IN}, between IN⁻ and V⁺ forces a potential across R_{IN} that is the same as the sense voltage across R_{SENSE}. A corresponding current, V_{SENSE}/R_{IN}, will flow through R_{IN}. The high impedance inputs of the sense amplifier will not conduct this input current, so it will flow through an internal MOSFET to the output pin.

The output current can be transformed into a voltage by adding a resistor from OUT to V⁻. The output voltage is then $V_O = V^- + I_{OUT} \cdot R_{OUT}$.

APPLICATIONS INFORMATION

Useful Gain Configurations

| Gain | R_{IN} | R_{OUT} | V_{SENSE} at $V_{OUT} = 5V$ | I_{OUT} at $V_{OUT} = 5V$ |
|------|----------|-----------|-------------------------------|-----------------------------|
| 20 | 499 | 10k | 250mV | 500 μ A |
| 50 | 200 | 10k | 100mV | 500 μ A |
| 100 | 100 | 10k | 50mV | 500 μ A |

Selection of External Current Sense Resistor

The external sense resistor, R_{SENSE} , has a significant effect on the function of a current sensing system and must be chosen with care.

First, the power dissipation in the resistor should be considered. The system load current will cause both heat and voltage loss in R_{SENSE} . As a result, the sense resistor should be as small as possible while still providing the input dynamic range required by the measurement. Note that input dynamic range is the difference between the maximum input signal and the minimum accurately reproduced signal, and is limited primarily by input DC offset of the internal amplifier of the LTC6101. In addition, R_{SENSE} must be small enough that V_{SENSE} does not exceed the maximum input voltage specified by the LTC6101, even under peak load conditions. As an example, an application may require that the maximum sense voltage be 100mV. If this application is expected to draw 2A at peak load, R_{SENSE} should be no more than 50m Ω .

Once the maximum R_{SENSE} value is determined, the minimum sense resistor value will be set by the resolution or dynamic range required. The minimum signal that can be accurately represented by this sense amp is limited by the input offset. As an example, the LTC6101B has a typical input offset of 150 μ V. If the minimum current is 20mA, a sense resistor of 7.5m Ω will set V_{SENSE} to 150 μ V. This is the same value as the input offset. A larger sense resistor will reduce the error due to offset by increasing the sense voltage for a given load current.

Choosing a 50m Ω R_{SENSE} will maximize the dynamic range and provide a system that has 100mV across the sense resistor at peak load (2A), while input offset causes an error equivalent to only 3mA of load current.

Peak dissipation is 200mW. If a 5m Ω sense resistor is employed, then the effective current error is 30mA, while the peak sense voltage is reduced to 10mV at 2A, dissipating only 20mW.

The low offset and corresponding large dynamic range of the LTC6101 make it more flexible than other solutions in this respect. The 150 μ V typical offset gives 60dB of dynamic range for a sense voltage that is limited to 150mV max, and over 70dB of dynamic range if the rated input maximum of 500mV is allowed.

Sense Resistor Connection

Kelvin connection of the IN^- and IN^+ inputs to the sense resistor should be used in all but the lowest power applications. Solder connections and PC board interconnections that carry high current can cause significant error in measurement due to their relatively large resistances. One 10mm x 10mm square trace of one-ounce copper is approximately 0.5m Ω . A 1mV error can be caused by as little as 2A flowing through this small interconnect. This will cause a 1% error in a 100mV signal. A 10A load current in the same interconnect will cause a 5% error for the same 100mV signal. By isolating the sense traces from the high-current paths, this error can be reduced by orders of magnitude. A sense resistor with integrated Kelvin sense terminals will give the best results. Figure 2 illustrates the recommended method.

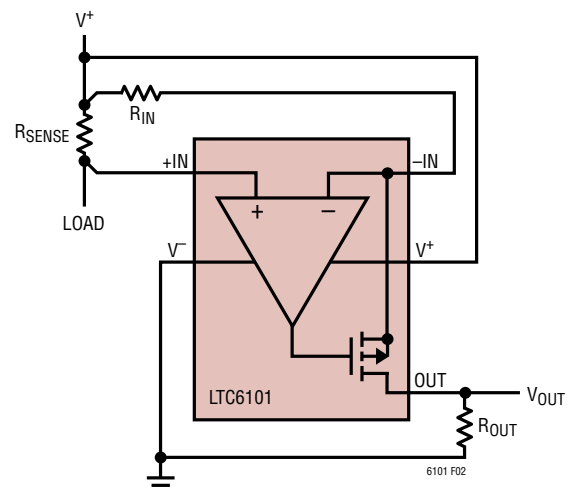

Figure 2. Kelvin Input Connection Preserves Accuracy Despite Large Load Current

APPLICATIONS INFORMATION

Selection of External Input Resistor, R_{IN}

The external input resistor, R_{IN} , controls the transconductance of the current sense circuit. Since $I_{OUT} = V_{SENSE}/R_{IN}$, transconductance $g_m = 1/R_{IN}$. For example, if $R_{IN} = 100$, then $I_{OUT} = V_{SENSE}/100$ or $I_{OUT} = 1\text{mA}$ for $V_{SENSE} = 100\text{mV}$.

R_{IN} should be chosen to allow the required resolution while limiting the output current. At low supply voltage, I_{OUT} may be as much as 1mA. By setting R_{IN} such that the largest expected sense voltage gives $I_{OUT} = 1\text{mA}$, then the maximum output dynamic range is available. Output dynamic range is limited by both the maximum allowed output current and the maximum allowed output voltage, as well as the minimum practical output signal. If less dynamic range is required, then R_{IN} can be increased accordingly, reducing the max output current and power dissipation. If low sense currents must be resolved accurately in a system that has very wide dynamic range, a smaller R_{IN} than the max current spec allows may be used if the max current is limited in another way, such as with a Schottky diode across R_{SENSE} (Figure 3a). This will reduce the high current measurement accuracy by limiting the result, while increasing the low current measurement resolution.

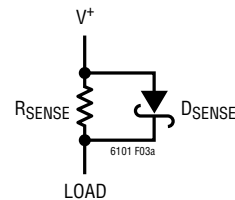

Figure 3a. Shunt Diode Limits Maximum Input Voltage to Allow Better Low Input Resolution Without Overranging

This approach can be helpful in cases where occasional large burst currents may be ignored. It can also be used in a multirange configuration where a low current circuit is added to a high current circuit (Figure 3b). Note that a comparator (LTC1540) is used to select the range, and transistor M1 limits the voltage across $R_{SENSE LO}$.

Care should be taken when designing the board layout for R_{IN} , especially for small R_{IN} values. All trace and interconnect impedances will increase the effective R_{IN} value, causing a gain error. In addition, internal device resistance will add approximately 0.2Ω to R_{IN} .

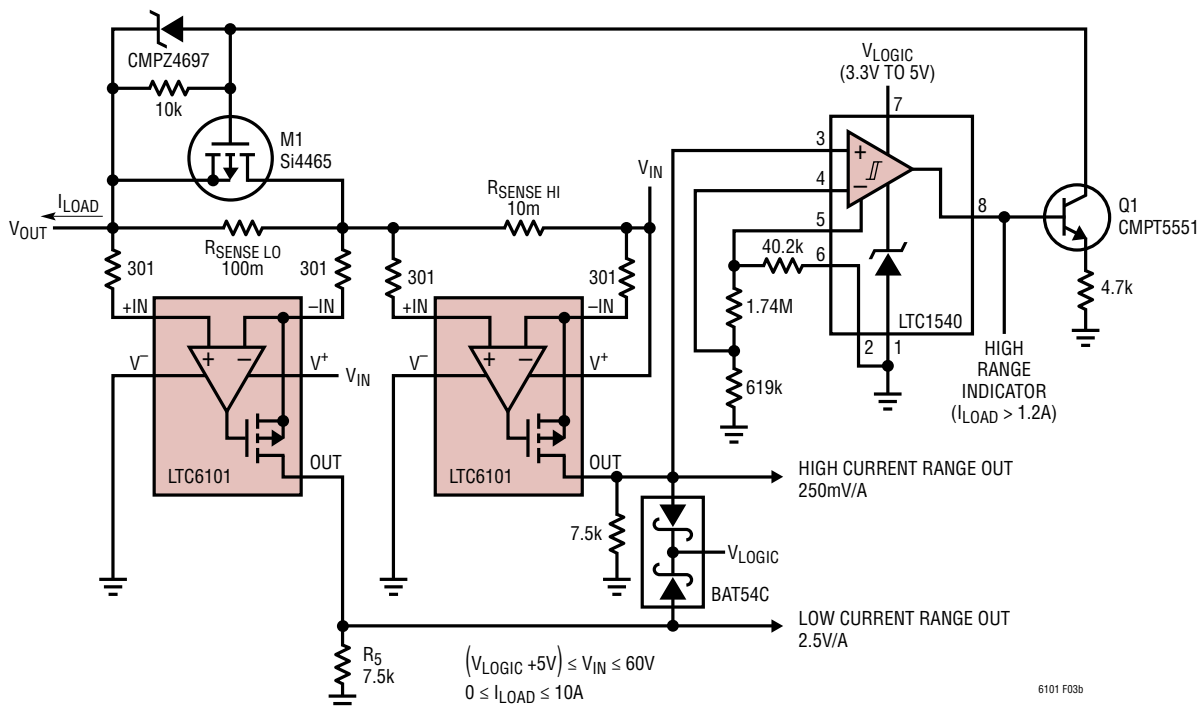

Figure 3b. Dual LTC6101s Allow High-Low Current Ranging

APPLICATIONS INFORMATION

Selection of External Output Resistor, R_{OUT}

The output resistor, R_{OUT} , determines how the output current is converted to voltage. V_{OUT} is simply $I_{OUT} \cdot R_{OUT}$.

In choosing an output resistor, the max output voltage must first be considered. If the circuit that is driven by the output does not limit the output voltage, then R_{OUT} must be chosen such that the max output voltage does not exceed the LTC6101 max output voltage rating. If the following circuit is a buffer or ADC with limited input range, then R_{OUT} must be chosen so that $I_{OUT(MAX)} \cdot R_{OUT}$ is less than the allowed maximum input range of this circuit.

In addition, the output impedance is determined by R_{OUT} . If the circuit to be driven has high enough input impedance, then almost any useful output impedance will be acceptable. However, if the driven circuit has relatively low input impedance, or draws spikes of current, such as an ADC might do, then a lower R_{OUT} value may be required in order to preserve the accuracy of the output. As an example, if the input impedance of the driven circuit is 100 times R_{OUT} , then the accuracy of V_{OUT} will be reduced by 1% since:

$$V_{OUT} = I_{OUT} \cdot \frac{R_{OUT} \cdot R_{IN(DRIVEN)}}{R_{OUT} + R_{IN(DRIVEN)}} \\ = I_{OUT} \cdot R_{OUT} \cdot \frac{100}{101} = 0.99 \cdot I_{OUT} \cdot R_{OUT}$$

Error Sources

The current sense system uses an amplifier and resistors to apply gain and level shift the result. The output is then dependent on the characteristics of the amplifier, such as gain and input offset, as well as resistor matching.

Ideally, the circuit output is:

$$V_{OUT} = V_{SENSE} \cdot \frac{R_{OUT}}{R_{IN}}; V_{SENSE} = R_{SENSE} \cdot I_{SENSE}$$

In this case, the only error is due to resistor mismatch, which provides an error in gain only. However, offset voltage, bias current and finite gain in the amplifier cause additional errors:

Output Error, E_{OUT} , Due to the Amplifier DC Offset Voltage, V_{OS}

$$E_{OUT(VOS)} = V_{OS} \cdot (R_{OUT}/R_{IN})$$

The DC offset voltage of the amplifier adds directly to the value of the sense voltage, V_{SENSE} . This is the dominant error of the system and it limits the available dynamic range. The paragraph "Selection of External Current Sense Resistor" provides details.

Output Error, E_{OUT} , Due to the Bias Currents, $I_B(+)$ and $I_B(-)$

The bias current $I_B(+)$ flows into the positive input of the internal op amp. $I_B(-)$ flows into the negative input.

$$E_{OUT(IBIAS)} = R_{OUT} \cdot (I_B(+) \cdot (R_{SENSE}/R_{IN}) - I_B(-))$$

Since $I_B(+) \approx I_B(-) = I_{BIAS}$, if $R_{SENSE} \ll R_{IN}$ then,

$$E_{OUT(IBIAS)} \approx -R_{OUT} \cdot I_{BIAS}$$

For instance if I_{BIAS} is 100nA and R_{OUT} is 1k Ω , the output error is 0.1mV.

Note that in applications where $R_{SENSE} \approx R_{IN}$, $I_B(+)$ causes a voltage offset in R_{SENSE} that cancels the error due to $I_B(-)$ and $E_{OUT(IBIAS)} \approx 0$. In applications where $R_{SENSE} < R_{IN}$, the bias current error can be similarly reduced if an external resistor $R_{IN(+)} = (R_{IN} - R_{SENSE})$ is connected as shown in Figure 4 below. Under both conditions:

$$E_{OUT(IBIAS)} = \pm R_{OUT} \cdot I_{OS}; I_{OS} = I_B(+) - I_B(-)$$

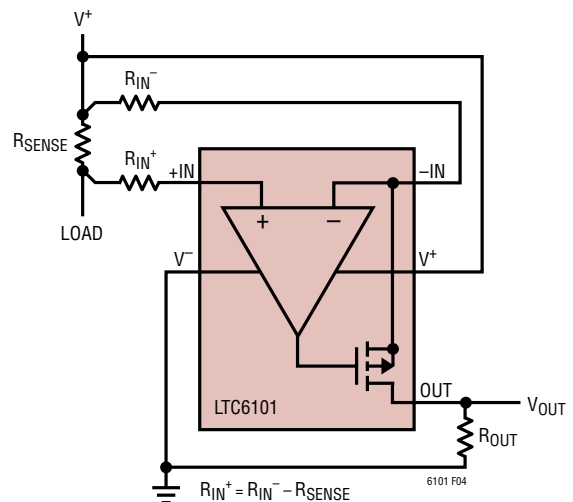

Figure 4. Second Input R Minimizes Error Due to Input Bias Current

APPLICATIONS INFORMATION

If the offset current, I_{OS} , of the LTC6101 amplifier is 2nA, the 100 microvolt error above is reduced to 2 microvolts. Adding R_{IN}^+ as described will maximize the dynamic range of the circuit. For less sensitive designs, R_{IN}^+ is not necessary.

Example:

If an I_{SENSE} range = (1A to 1mA) and $(V_{OUT}/I_{SENSE}) = 3V/1A$

Then, from the Electrical Characteristics of the LTC6101, $R_{SENSE} \approx V_{SENSE}(\text{max}) / I_{SENSE}(\text{max}) = 500\text{mV}/1A = 500\text{m}\Omega$

Gain = $R_{OUT}/R_{IN} = V_{OUT}(\text{max}) / V_{SENSE}(\text{max}) = 3V/500\text{mV} = 6$

If the maximum output current, I_{OUT} , is limited to 1mA, R_{OUT} equals $3V/1\text{mA} \approx 3.01\text{ k}\Omega$ (1% value) and $R_{IN} = 3\text{k}\Omega/6 \approx 499\Omega$ (1% value).

The output error due to DC offset is $\pm 900\mu\text{Volts}$ (typ) and the error due to offset current, I_{OS} is $3\text{k} \times 2\text{nA} = \pm 6\mu\text{Volts}$ (typical), provided $R_{IN}^+ = R_{IN}^-$.

The maximum output error can therefore reach $\pm 906\mu\text{Volts}$ or 0.03% (-70dB) of the output full scale. Considering the system input 60dB dynamic range ($I_{SENSE} = 1\text{mA}$ to 1A), the 70dB performance of the LTC6101 makes this application feasible.

Output Error, E_{OUT} , Due to the Finite DC Open Loop Gain, A_{OL} , of the LTC6101 Amplifier

This error is inconsequential as the A_{OL} of the LTC6101 is very large.

Output Current Limitations Due to Power Dissipation

The LTC6101 can deliver up to 1mA continuous current to the output pin. This current flows through R_{IN} and enters the current sense amp via the $IN(-)$ pin. The power dissipated in the LTC6101 due to the output signal is:

$$P_{OUT} = (V_{-IN} - V_{OUT}) \cdot I_{OUT}$$

$$\text{Since } V_{-IN} \approx V^+, P_{OUT} \approx (V^+ - V_{OUT}) \cdot I_{OUT}$$

There is also power dissipated due to the quiescent supply current:

$$P_Q = I_{DD} \cdot V^+$$

The total power dissipated is the output dissipation plus the quiescent dissipation:

$$P_{TOTAL} = P_{OUT} + P_Q$$

At maximum supply and maximum output current, the total power dissipation can exceed 100mW. This will cause significant heating of the LTC6101 die. In order to prevent damage to the LTC6101, the maximum expected dissipation in each application should be calculated. This number can be multiplied by the θ_{JA} value listed in the package section on page 2 to find the maximum expected die temperature. This must not be allowed to exceed 150°C, or performance may be degraded.

As an example, if an LTC6101 in the S5 package is to be run at 55V \pm 5V supply with 1mA output current at 80°C:

$$P_{Q(MAX)} = I_{DD(MAX)} \cdot V^+(MAX) = 41.4\text{mW}$$

$$P_{OUT(MAX)} = I_{OUT} \cdot V^+(MAX) = 60\text{mW}$$

$$T_{RISE} = \theta_{JA} \cdot P_{TOTAL(MAX)}$$

$$T_{MAX} = T_{AMBIENT} + T_{RISE}$$

$$T_{MAX} \text{ must be } < 150^\circ\text{C}$$

$P_{TOTAL(MAX)} \approx 96\text{mW}$ and the max die temp will be 104°C

If this same circuit must run at 125°C, the max die temp will increase to 150°C. (Note that supply current, and therefore P_Q , is proportional to temperature. Refer to Typical Performance Characteristics section.) In this condition, the maximum output current should be reduced to avoid device damage. Note that the MSOP package has a larger θ_{JA} than the S5, so additional care must be taken when operating the LTC6101A/LTC6101HVA at high temperatures and high output currents.

The LTC6101HV can be used at voltages up to 105V. This additional voltage requires that more power be dissipated for a given level of current. This will further limit the allowed output current at high ambient temperatures.

It is important to note that the LTC6101 has been designed to provide at least 1mA to the output when required, and can deliver more depending on the conditions. Care must be taken to limit the maximum output current by proper choice of sense resistor and, if input fault conditions exist, external clamps.

APPLICATIONS INFORMATION

Output Filtering

The output voltage, V_{OUT} , is simply $I_{OUT} \cdot Z_{OUT}$. This makes filtering straightforward. Any circuit may be used which generates the required Z_{OUT} to get the desired filter response. For example, a capacitor in parallel with R_{OUT} will give a low pass response. This will reduce unwanted noise from the output, and may also be useful as a charge reservoir to keep the output steady while driving a switching circuit such as a mux or ADC. This output capacitor in parallel with an output resistor will create a pole in the output response at:

$$f_{-3dB} = \frac{1}{2 \cdot \pi \cdot R_{OUT} \cdot C_{OUT}}$$

Useful Equations

Input Voltage: $V_{SENSE} = I_{SENSE} \cdot R_{SENSE}$

Voltage Gain: $\frac{V_{OUT}}{V_{SENSE}} = \frac{R_{OUT}}{R_{IN}}$

Current Gain: $\frac{I_{OUT}}{I_{SENSE}} = \frac{R_{SENSE}}{R_{IN}}$

Transconductance: $\frac{I_{OUT}}{V_{SENSE}} = \frac{1}{R_{IN}}$

Transimpedance: $\frac{V_{OUT}}{I_{SENSE}} = R_{SENSE} \cdot \frac{R_{OUT}}{R_{IN}}$

Input Common Mode Range

The inputs of the LTC6101 can function from 1.5V below the positive supply to 0.5V above it. Not only does this allow a wide V_{SENSE} range, it also allows the input reference to be separate from the positive supply (Figure 5). Note that the difference between V_{BATT} and V^+ must be no more than the common mode range listed in the Electrical Characteristics table. If the maximum V_{SENSE} is less than 500mV, the LTC6101 may monitor its own supply current, as well as that of the load (Figure 6).

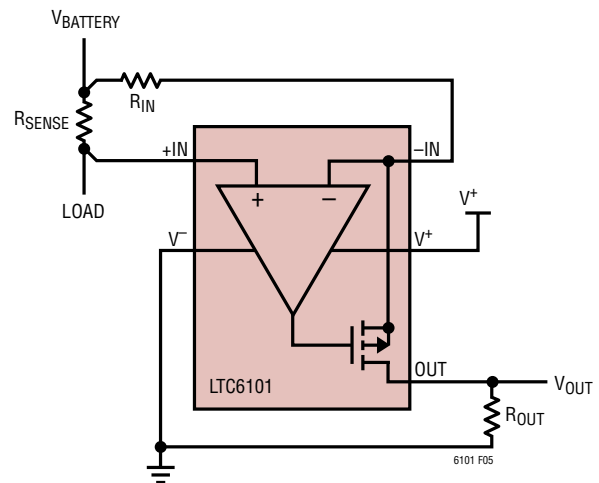

Figure 5. V^+ Powered Separately from Load Supply (V_{BATT})

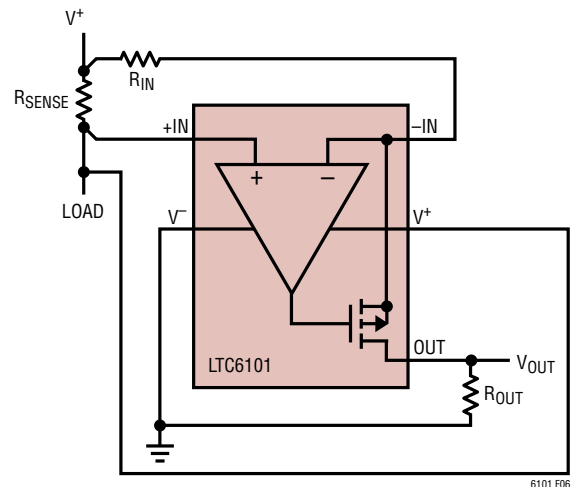

Figure 6. LTC6101 Supply Current Monitored with Load

APPLICATIONS INFORMATION

Reverse Supply Protection

Some applications may be tested with reverse-polarity supplies due to an expectation of this type of fault during operation. The LTC6101 is not protected internally from external reversal of supply polarity. To prevent damage that may occur during this condition, a Schottky diode should be added in series with V^- (Figure 7). This will limit the reverse current through the LTC6101. Note that this diode will limit the low voltage performance of the LTC6101 by effectively reducing the supply voltage to the part by V_D .

In addition, if the output of the LTC6101 is wired to a device that will effectively short it to high voltage (such as through an ESD protection clamp) during a reverse supply condition, the LTC6101's output should be connected through a resistor or Schottky diode (Figure 8).

Response Time

The LTC6101 is designed to exhibit fast response to inputs for the purpose of circuit protection or signal transmission. This response time will be affected by the external circuit in two ways, delay and speed.

If the output current is very low and an input transient occurs, there may be an increased delay before the output voltage begins changing. This can be improved by increasing the minimum output current, either by increasing R_{SENSE} or decreasing R_{IN} . The effect of increased output current is illustrated in the step response curves in the Typical Performance Characteristics section of this data

sheet. Note that the curves are labeled with respect to the initial output currents.

The speed is also affected by the external circuit. In this case, if the input changes very quickly, the internal amplifier will slew the gate of the internal output FET (Figure 1) in order to maintain the internal loop. This results in current flowing through R_{IN} and the internal FET. This current slew rate will be determined by the amplifier and FET characteristics as well as the input resistor, R_{IN} . Using a smaller R_{IN} will allow the output current to increase more quickly, decreasing the response time at the output. This will also have the effect of increasing the maximum output current. Using a larger R_{OUT} will decrease the response time, since $V_{OUT} = I_{OUT} \cdot R_{OUT}$. Reducing R_{IN} and increasing R_{OUT} will both have the effect of increasing the voltage gain of the circuit.

High Voltage Spacing

For applications with higher voltage, the TSOT-23 HV pinout of the LTC6101HV eases the printed circuit board (PCB) layout burden. In the typical high side current sense configuration, the sense voltages will be at or very near the supply; normally the sense difference voltage is small. Therefore V^+ , $+IN$ and $-IN$ will be roughly the same voltage. The TSOT-23 HV pinout provides connection for these three pins on the left side (Top View). Because voltage differences between these high side pins and the OUT and V^- pin may be high, the OUT and V^- pin lie separately, on the right side of the package.

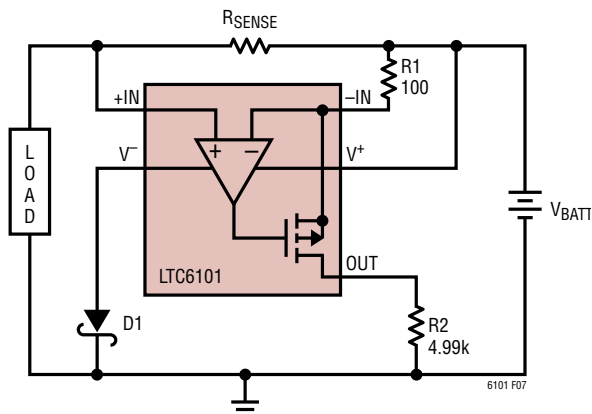

Figure 7. Schottky Prevents Damage During Supply Reversal

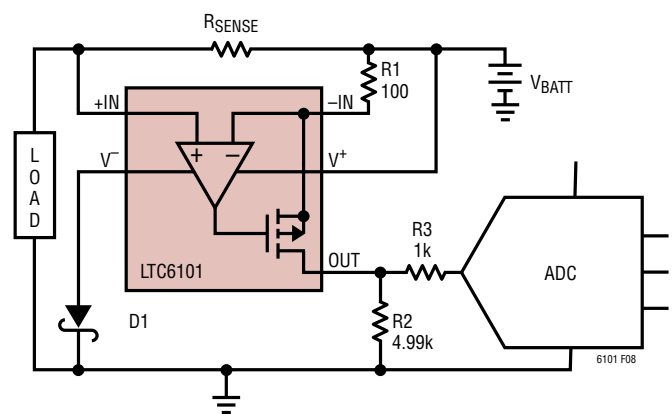
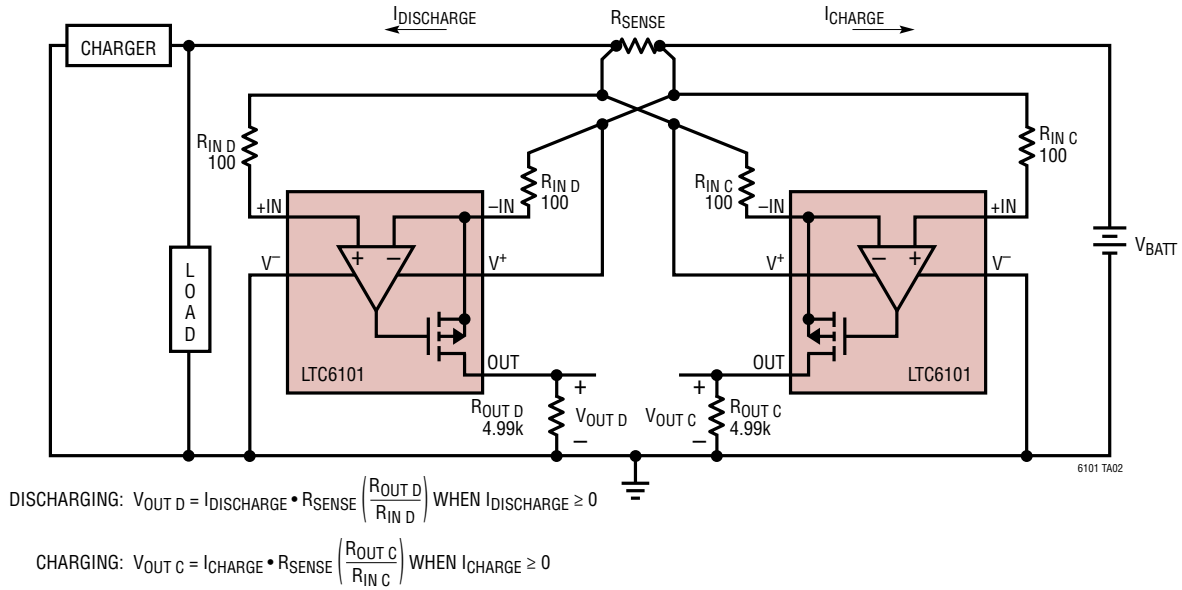

Figure 8. Additional Resistor R3 Protects Output During Supply Reversal

TYPICAL APPLICATIONS

Bidirectional Current Sense Circuit with Separate Charge/Discharge Output



LTC6101 Monitors Its Own Supply Current

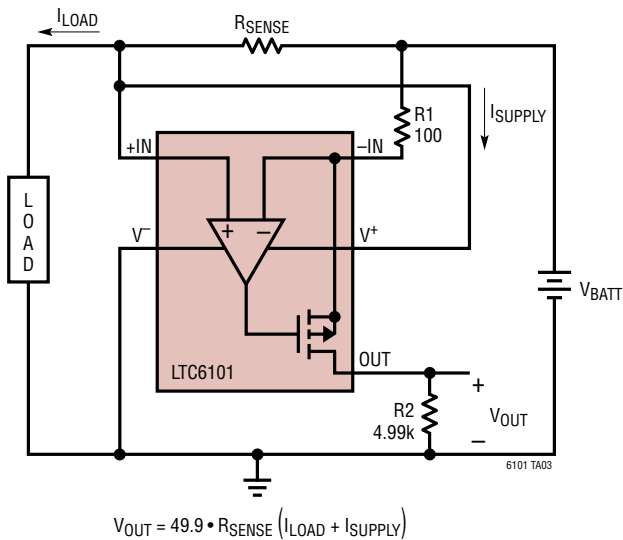

High-Side-Input Transimpedance Amplifier

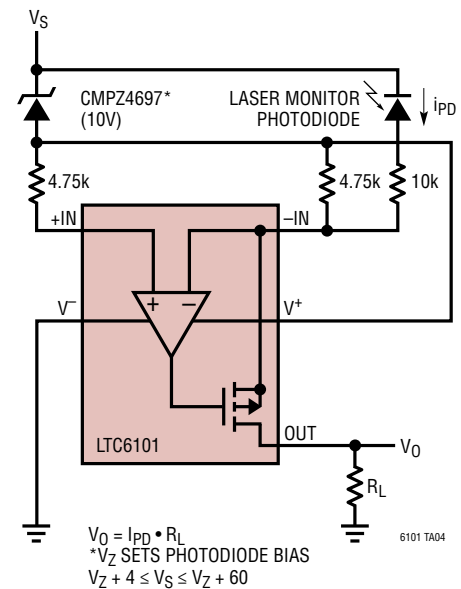

TYPICAL APPLICATIONS

16-Bit Resolution Unidirectional Output into LTC2433 ADC

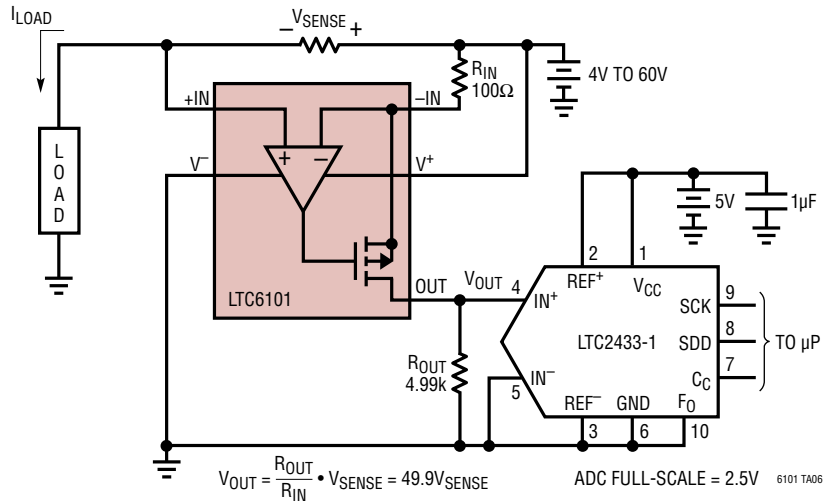

Intelligent High-Side Switch with Current Monitor

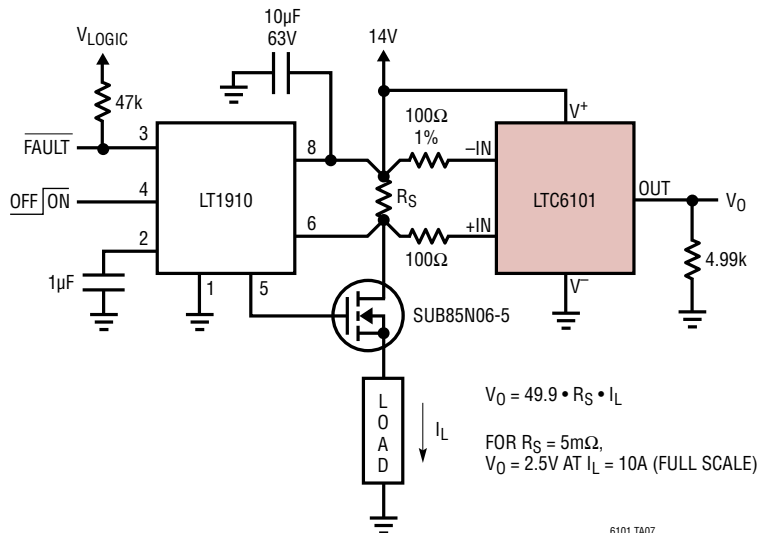

TYPICAL APPLICATIONS

48V Supply Current Monitor with Isolated Output with 105V Survivability

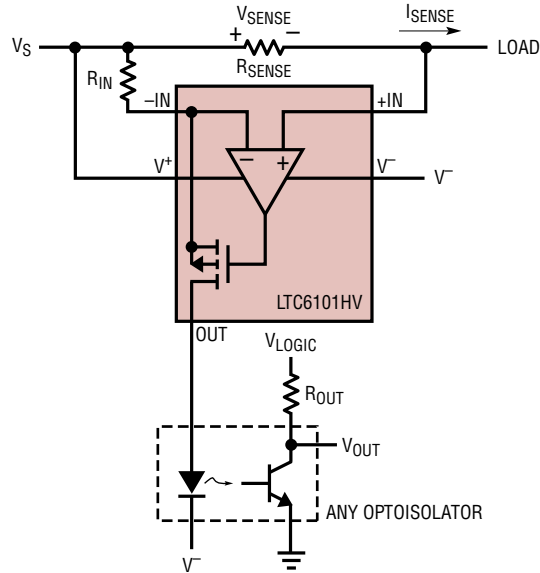

N = OPTOISOLATOR CURRENT GAIN

$$V_{OUT} = V_{LOGIC} - I_{SENSE} \cdot \frac{R_{SENSE}}{R_{IN}} \cdot N \cdot R_{OUT}$$

6101 TA08

Simple 500V Current Monitor

DANGER! Lethal Potentials Present — Use Caution

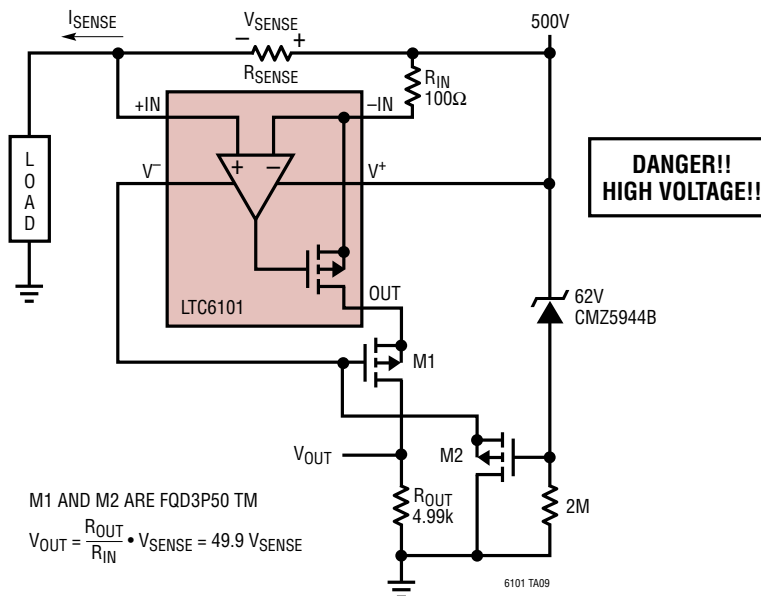

M1 AND M2 ARE FQD3P50 TM

$$V_{OUT} = \frac{R_{OUT}}{R_{IN}} \cdot V_{SENSE} = 49.9 V_{SENSE}$$

6101 TA09

PACKAGE DESCRIPTION

Please refer to <http://www.linear.com/product/LTC6101#packaging> for the most recent package drawings.

MS8 Package 8-Lead Plastic MSOP (Reference LTC DWG # 05-08-1660 Rev G)

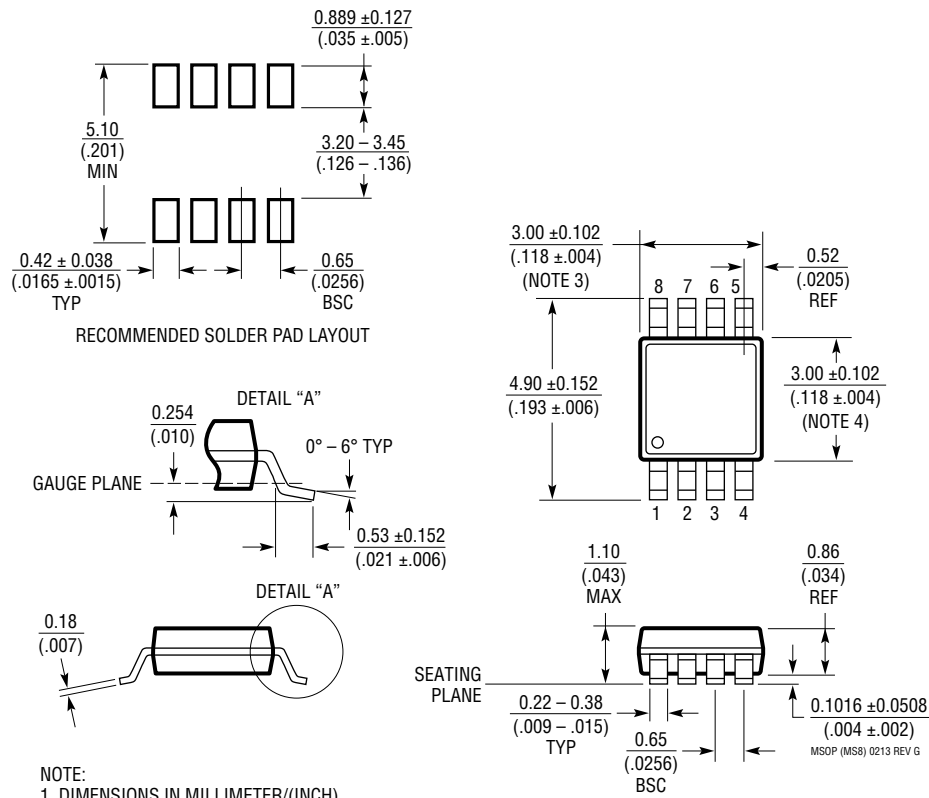

PACKAGE DESCRIPTION

Please refer to <http://www.linear.com/product/LTC6101#packaging> for the most recent package drawings.

S5 Package 5-Lead Plastic TSOT-23 (Reference LTC DWG # 05-08-1635 Rev B)

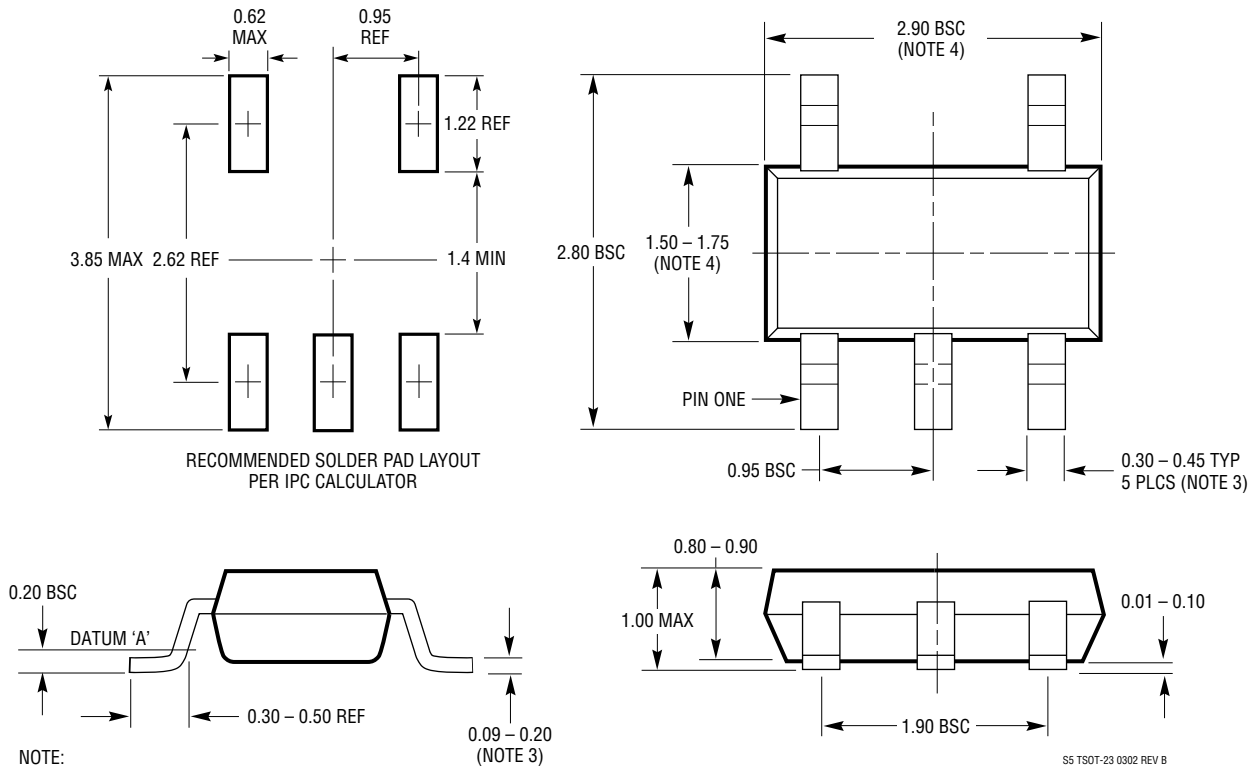

REVISION HISTORY (Revision history begins at Rev H)

| REV | DATE | DESCRIPTION | PAGE NUMBER |
|-----|-------|---|-----------------------------------|
| H | 03/12 | Updated Features | 1 |
| | | Updated Absolute Maximum Ratings and changed Order Information | 2 |
| | | Changed operating temperature range to specified temperature range in Electrical Characteristics header | 4, 5 |
| | | Changed T _A value in curve G02 from 45°C to 25°C | 6 |
| I | 05/18 | Adding new TSOT package option | 1 to 3, 5 to 9, 13, 15, 18, 21 |

TYPICAL APPLICATION

Bidirectional Current Sense Circuit with Combined Charge/Discharge Output

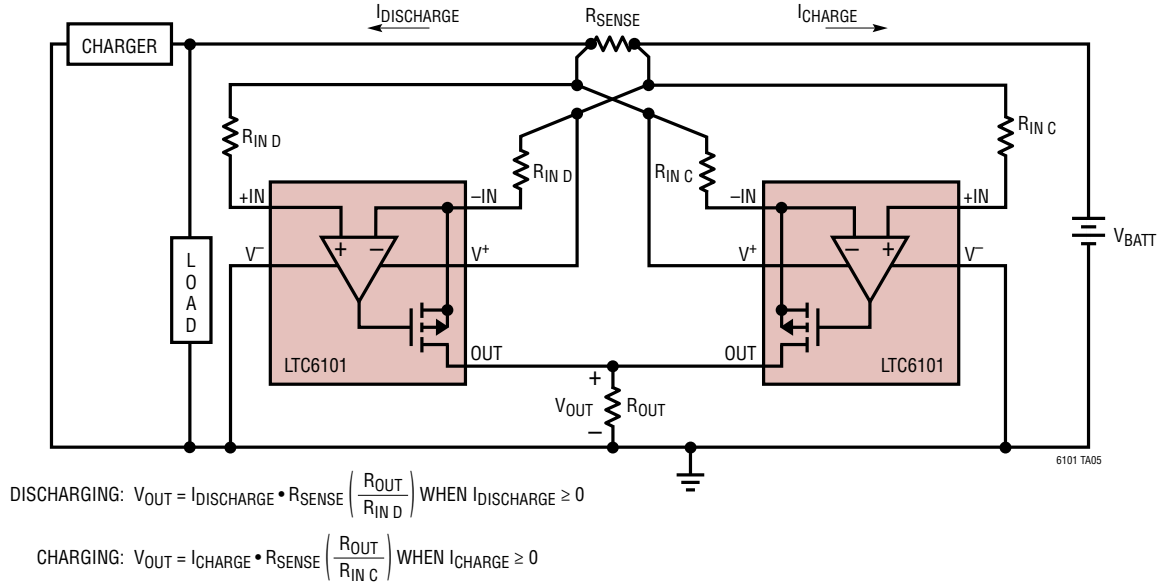

RELATED PARTS

| PART NUMBER | DESCRIPTION | COMMENTS |
|---|---|---|
| LT1636 | Rail-to-Rail Input/Output, Micropower Op Amp | V_{CM} Extends 44V above V_{EE} , 55 μ A Supply Current, Shutdown Function |
| LT1637/LT1638/LT1639 | Single/Dual/Quad, Rail-to-Rail, Micropower Op Amp | V_{CM} Extends 44V above V_{EE} , 0.4V/ μ s Slew Rate, >1MHz Bandwidth, <250 μ A Supply Current per Amplifier |
| LT1787/LT1787HV | Precision, Bidirectional, High Side Current Sense Amplifier | 2.7V to 60V Operation, 75 μ V Offset, 60 μ A Current Draw |
| LTC1921 | Dual -48V Supply and Fuse Monitor | \pm 200V Transient Protection, Drives Three Optoisolators for Status |
| LT1990 | High Voltage, Gain Selectable Difference Amplifier | \pm 250V Common Mode, Micropower, Pin Selectable Gain = 1, 10 |
| LT1991 | Precision, Gain Selectable Difference Amplifier | 2.7V to \pm 18V, Micropower, Pin Selectable Gain = -13 to 14 |
| LTC2050/LTC2051/LTC2052 | Single/Dual/Quad Zero-Drift Op Amp | 3 μ V Offset, 30nV/ $^{\circ}$ C Drift, Input Extends Down to V_{-} |
| LTC4150 | Coulomb Counter/Battery Gas Gauge | Indicates Charge Quantity and Polarity |
| LT6100 | Gain-Selectable High-Side Current Sense Amplifier | 4.1V to 48V Operation, Pin-Selectable Gain: 10, 12.5, 20, 25, 40, 50V/V |