

# Micropower Synchronous Buck-Boost DC/DC Converter for WCDMA Applications

## FEATURES

- Optimized Features for WCDMA Handsets
- Regulated Output with Input Voltages Above, Below, or Equal to the Output
- 0.5V to 5V Output Range
- Up to 400mA Continuous Output Current From a Single Lithium-Ion Cell
- Minimal External Components
- 1.5MHz Fixed Frequency Operation
- Internal Loop Compensation for Fast Response <math><25\mu\text{s}</math> Full Scale Output Slewing;  $C_{\text{OUT}} 4.7\mu\text{F}</math>$
- Output Disconnect in Shutdown
- 2.75V to 5.5V Input
- $<1\mu\text{A}</math> Shutdown Current$
- Internal Soft-Start
- Output Overvoltage Protection
- Single Inductor, No Schottky Diodes Required
- Small, Thermally Enhanced 8-Lead (3mm  $\times$  3mm) DFN Package

## APPLICATIONS

- WCDMA Applications—3G Handsets with High Speed Data Rate Capability
- MP3 Players
- Digital Cameras

## DESCRIPTION

The LTC<sup>®</sup>3444 is a highly efficient, fixed frequency, buck-boost DC/DC converter, which operates from input voltages above, below, and equal to the output voltage. The topology incorporated in the IC provides a continuous transfer function through all operating modes, making the product ideal for a single Lithium-Ion or multi-cell applications where the output voltage can vary over a wide range.

The LTC3444 has been optimized for use in 3G WCDMA applications. A unique design yields high efficiency at very low output voltages while also eliminating external components. The high speed error amplifier provides the fast transient response required to slew the RF power amplifier from standby to transmit and transmit to standby power levels. Output overvoltage protection protects the RF power amplifier.

Operating frequency is internally set to 1.5MHz to minimize external component size while maximizing efficiency.

Other features include  $<1\mu\text{A}</math> shutdown current, internal soft-start, peak current limit and thermal shutdown. The LTC3444 is available in a small, thermally enhanced 8-lead (3mm  $\times$  3mm) DFN package.$

LT, LT, LTC and LTM are registered trademarks of Linear Technology Corporation. All other trademarks are the property of their respective owners. Protected by U.S. Patents including 6404251, 6166527.

## TYPICAL APPLICATION

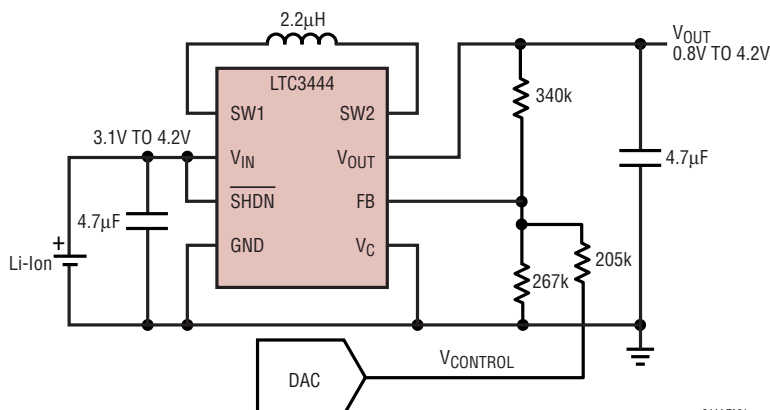

### LTC3444 Dynamic Response

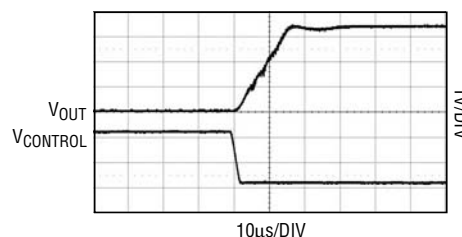

$V_{\text{IN}} = 3.6\text{V}$ ,  $V_{\text{OUT}} = 0.8\text{V TO } 4.2\text{V}$   
 $V_{\text{CONTROL}} = 2.36\text{V TO } 0.28\text{V}$ ,  $I_{\text{LOAD}} = 100\text{mA}$

3444 TA01

3444 G16a



# ELECTRICAL CHARACTERISTICS

The ● denotes specifications which apply over the full operating temperature range, otherwise specifications are  $T_A = 25^\circ\text{C}$ .  $V_{IN} = V_{OUT} = 3.6\text{V}$  unless otherwise noted.

PARAMETER	CONDITIONS		MIN	TYP	MAX	UNITS
SHDN Threshold (On)	IC is Enabled	●	1.4			V
SHDN Threshold (Off)	IC is Disabled	●			0.4	V
SHDN Input Current	$V_{SHDN} = 3.6\text{V}$			0.01	1	$\mu\text{A}$
$V_C$ Output Current	$V_C = \text{GND}$			0.5	2	$\mu\text{A}$

**Note 1:** Stresses beyond those listed under Absolute Maximum Ratings may cause permanent damage to the device. Exposure to any Absolute Maximum Rating condition for extended periods may affect device reliability and lifetime.

**Note 2:** The LTC3444E is guaranteed to meet performance specifications from  $0^\circ\text{C}$  to  $85^\circ\text{C}$ . Specifications over the  $-40^\circ\text{C}$  to  $85^\circ\text{C}$  operating temperature range are assured by design, characterization and correlation with statistical process controls.

**Note 3:** Current measurements are performed when the outputs are not switching.

**Note 4:** This IC includes overtemperature protection that is intended to protect the device during momentary overload conditions. Junction temperature will exceed  $125^\circ\text{C}$  when overtemperature is active. Continuous operation above the specified maximum operating junction temperature may result in device degradation or failure.

# TYPICAL PERFORMANCE CHARACTERISTICS ( $T_A = 25^\circ\text{C}$ unless otherwise specified)

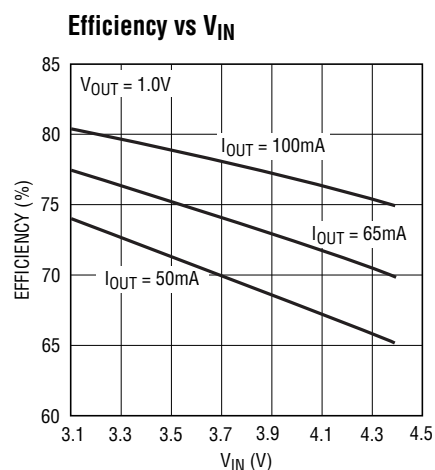

3444 G03

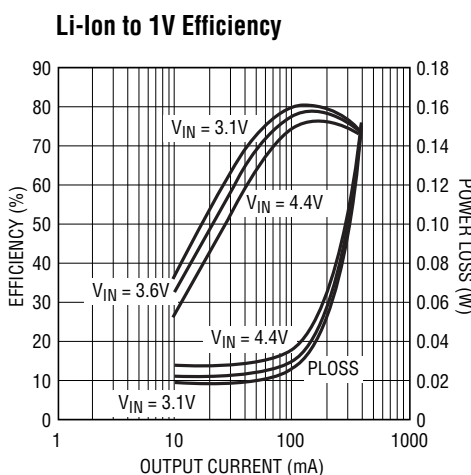

3444 G06

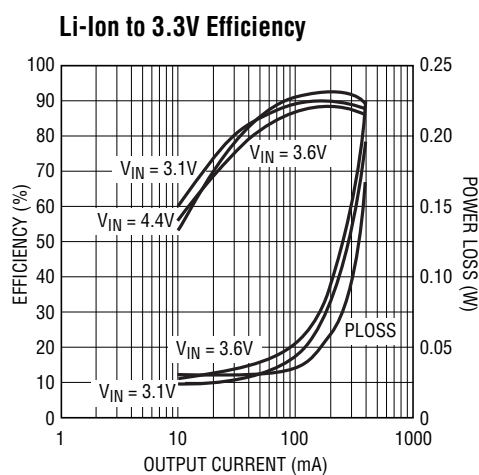

3444 G05

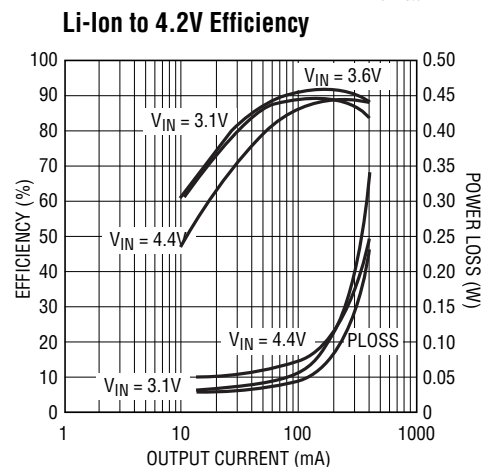

3444 G04

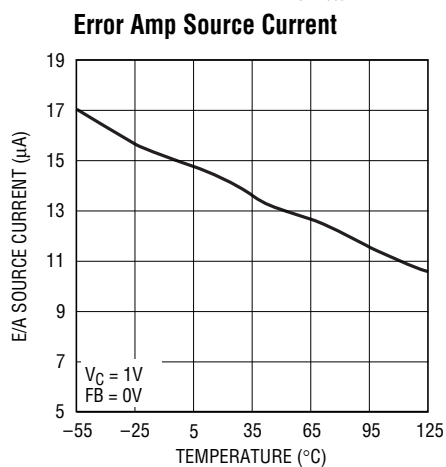

3444 G07

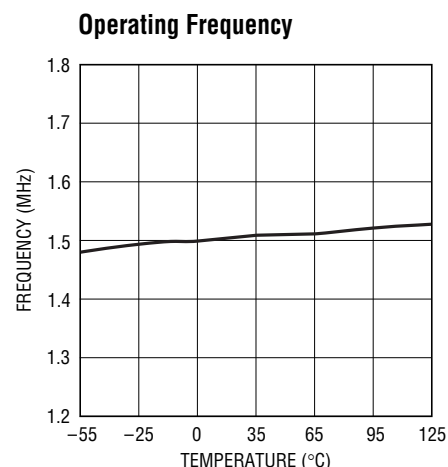

3444 G08

**TYPICAL PERFORMANCE CHARACTERISTICS** ( $T_A = 25^\circ\text{C}$  unless otherwise specified)

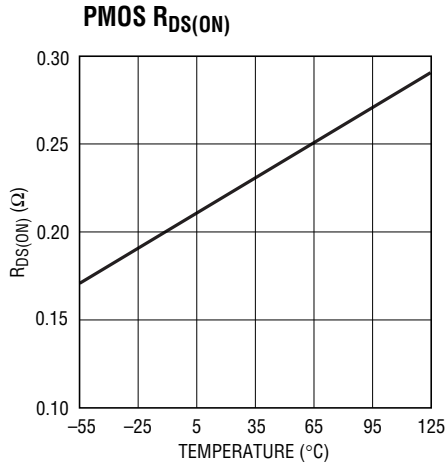

3444 G09

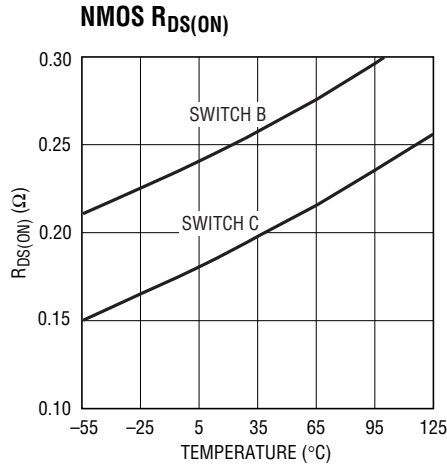

3444 G10

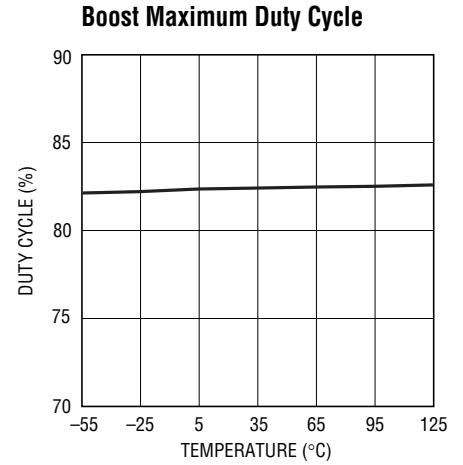

3444 G11

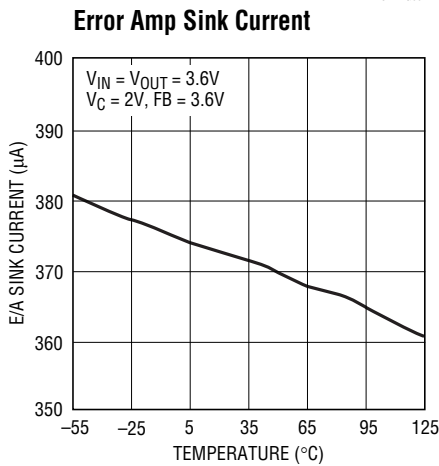

3444 G12

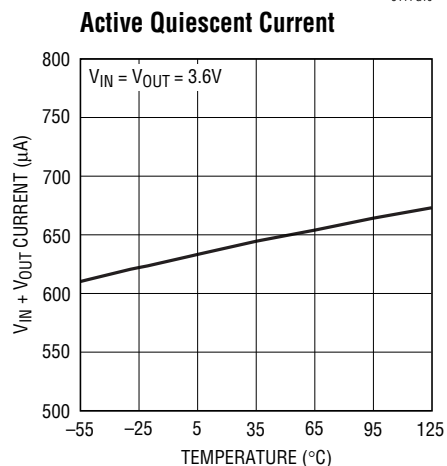

3444 G13

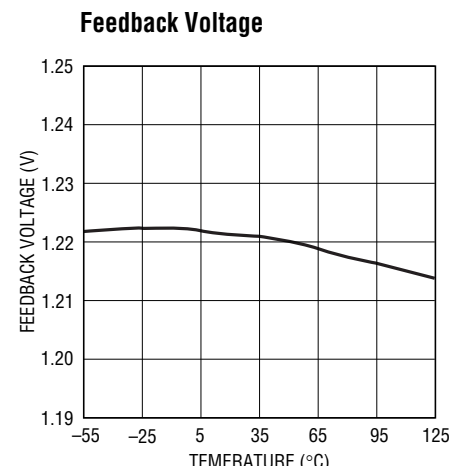

3444 G14

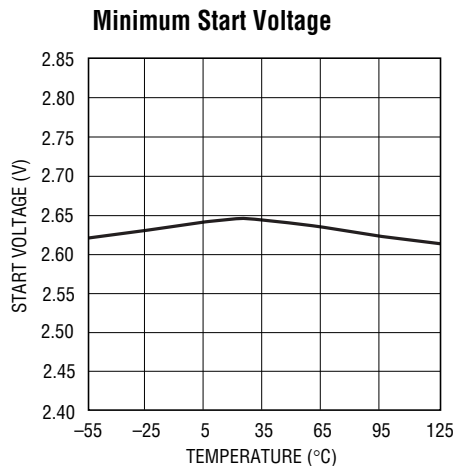

3444 G15

## PIN FUNCTIONS

**SHDN (Pin 1):** Shutdown Function. A logic low input shuts down the IC. A logic high input enables the IC and starts the internal soft-start function by limiting the rise time of the internal PWM command.

**SW1 (Pin 2):** Switch Pin Where the Internal Switches A and B are Connected. Connect inductor from SW1 to SW2. An optional Schottky diode can be connected from ground to SW1 for a moderate efficiency improvement. Minimize trace length to minimize EMI.

**GND (Pin 3):** Ground Pin for the IC.

**SW2 (Pin 4):** Switch Pin Where the Internal Switches C and D are Connected. An optional Schottky diode can be connected from SW2 to  $V_{OUT}$  for a moderate efficiency improvement. Minimize trace length to keep EMI down.

**$V_{OUT}$  (Pin 5):** Output of the Synchronous Rectifier. A filter capacitor is placed from  $V_{OUT}$  to GND. A ceramic bypass capacitor is recommended as close to the  $V_{OUT}$  and GND pins as possible.

**$V_{IN}$  (Pin 6):** Input Supply Pin. Internal  $V_{CC}$  for the IC. A 4.7 $\mu$ F ceramic capacitor is recommended as close to  $V_{IN}$  and GND as possible.

**$V_C$  (Pin 7):** Error Amp Output. Pull  $V_C$  to ground to select internal loop compensation. External compensation may be connected from  $V_C$  to FB. Internal compensation will be disabled if  $V_C$  is tied to an external compensation network.

**FB (Pin 8):** Feedback Pin. Connect resistive divider tap here. The output voltage can be adjusted from 0.5V to 5V. The feedback reference voltage is typically 1.22V.

**GND (Pin 9, Exposed Pad):** Solder to Board GND.

**BLOCK DIAGRAM**

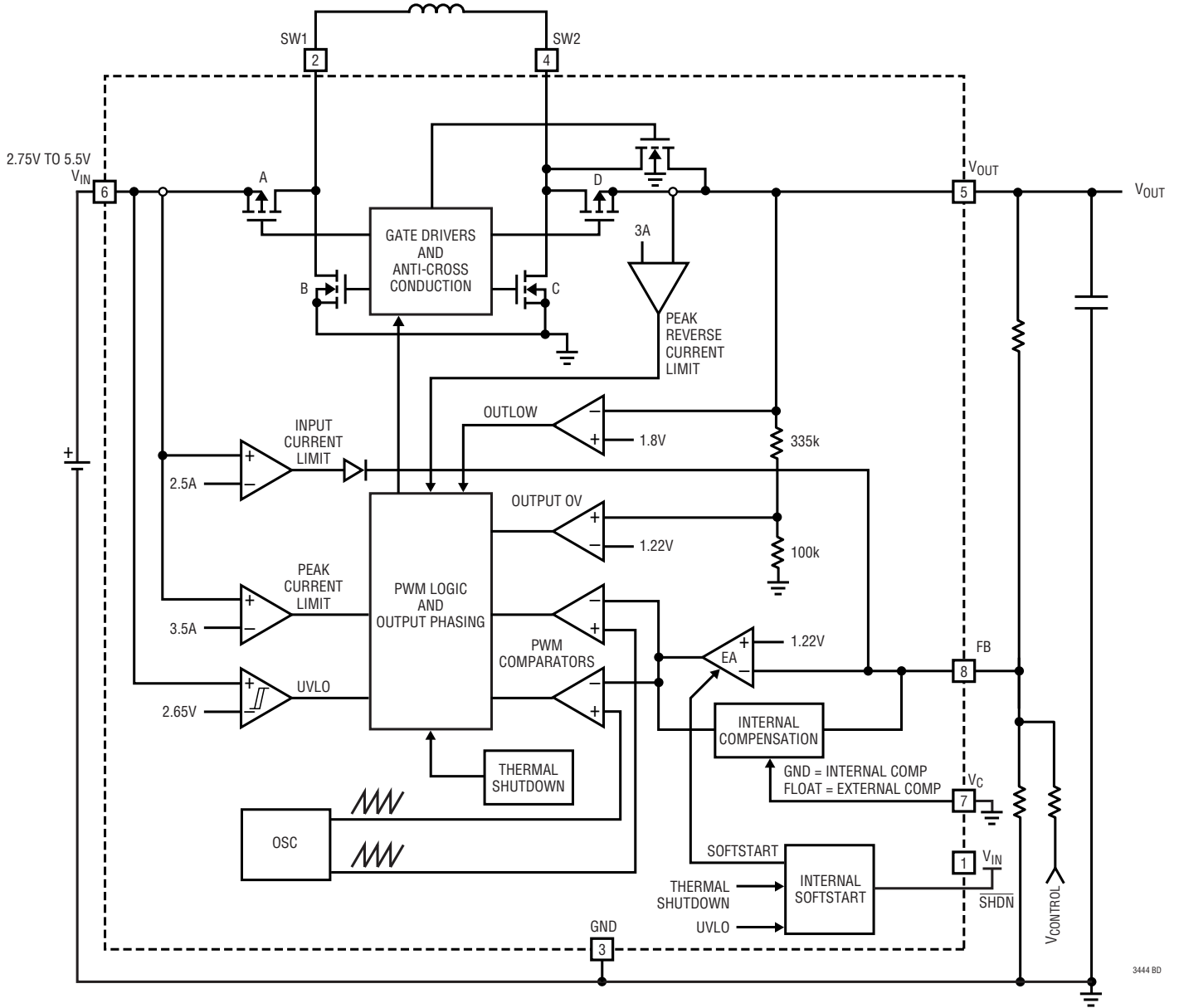

3444 BD

## OPERATION

The LTC3444 is a highly efficient, fixed frequency, buck-boost DC/DC converter, which operates from input voltages above, below, and equal to the output voltage. The topology incorporated in the IC provides a continuous transfer function through all operating modes, making the product ideal for single Lithium-Ion or multi-cell applications where the output voltage can vary over a wide range.

The LTC3444 is designed to provide dynamic voltage control in space constrained 3G WCDMA applications. Due to the high operating frequency and integrated loop compensation a complete WCDMA application requires only six additional components; input and output capacitors (ceramic), an inductor, and three resistors. The high speed error amplifier and integrated loop compensation provide the fast transient response required to slew the RF power amplifier's voltage rail from standby to transmit and transmit to standby levels in  $< 25\mu\text{s}$  while minimizing output overshoot or undershoot.

Efficiency under low output voltage conditions (standby mode) is improved by using an N-channel

MOSFET in parallel to P-channel MOSFET switch D. This parallel MOSFET eliminates the need for an external Schottky. Output overvoltage protection protects the RF power amplifier from voltages greater than 5.5V.

When used with the proper inductance and output capacitance, the LTC3444 internal compensation is designed to be consistent with the transient requirements of a typical WCDMA application. External compensation can be used with other combinations of inductance and output capacitance, however, the transient response may not be consistent with typical WCDMA requirements.

Output voltage programming is accomplished via a summing resistor input to the feedback resistive divider string. The output voltage varies inversely with the command voltage. When using the internal loop compensation, resistor R1 in the feedback resistive divider string must be 340k. There are no constraints on R1 when using external compensation. However, lower value resistors will decrease the resistance value required for programming the output voltage. Care must be taken not to load down the control voltage source.

## OPERATION

### Error Amp

The LTC3444 error amplifier is a voltage mode amplifier. The internal loop compensation is designed to optimize transient response to control input change when the proper output L-C and R1 values are used. Refer to Figure 1.

Internal loop compensation is selected by grounding the  $V_C$  pin. The loop is designed to exhibit a single pole roll-off (-20dB/dec) with a crossover frequency of ~100KHz. External compensation can be used by connecting the compensation components from FB to  $V_C$ . The  $V_C$  pin must be allowed to float when using external compensation. If external compensation is used the internal compensation is automatically disabled. A Type III compensation network is typically required to meet the output transient requirements of WCDMA.

During start-up, the ramp rate of the error amp output is controlled to provide a soft-start function. Refer to Figure 2.

### Internal Current Limit

There are two different current limit circuits in the LTC3444. The two circuits have internally fixed thresholds.

The first circuit sources current out of the FB pin to drop the output voltage once the peak input current exceeds 2.5A minimum. During conditions where  $V_{OUT}$  is near ground, such as during a short circuit or during startup, this threshold is cut in half, providing current foldback protection.

The second circuit is a high-speed peak current limit amplifier that shuts off P-channel MOSFET switch A if the input current exceeds 3.5A typical. The delay to output for this amplifier is typically 50ns.

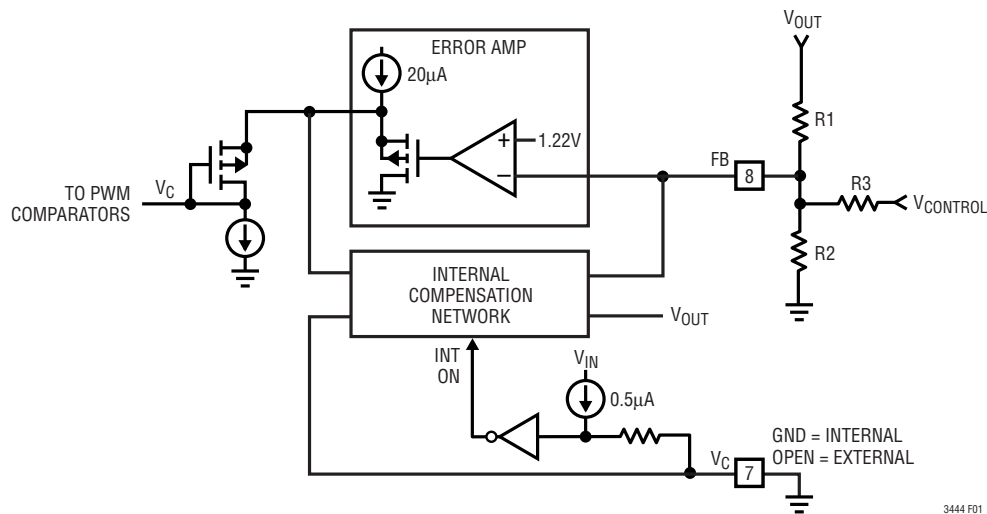

Figure 1. Error Amplifier with Compensation Select Function

3444 F01



## OPERATION

### Reverse Current Limit

The LTC3444 always operates in forced continuous conduction mode. The reverse current limit amplifier monitors the inductor current from the output through switch D. Once the negative inductor current exceeds 3A minimum, the LTC3444 will shut off switch D. The high reverse current is required to meet the transient slew requirements for WCDMA power amplifiers.

### Output Overvoltage Protection

The LTC3444 provides output overvoltage protection. If the output voltage exceeds 5.3V typical, P-channel MOSFET switches A and D are turned off and N-channel MOSFET switches B and C are turned on. Normal switching will

resume once the output voltage drops below  $\sim 5.1V$ . If the condition which caused the output overvoltage is still present the output will charge up to 5.3V again and the overvoltage cycle will be repeat. Normal output regulation will resume once the condition responsible for the output overvoltage is removed.

### Soft-Start

The soft-start function is initiated when the  $\overline{SHDN}$  pin is brought above 1.4V and the LTC3444 is out of UVLO (above minimum input operating specs). The LTC3444 is enabled but the PWM duty cycle is clamped via the error amp output. The soft-start time is internally set to 250 $\mu s$  to minimize output overshoot. A detailed diagram of this function is shown in Figure 2.

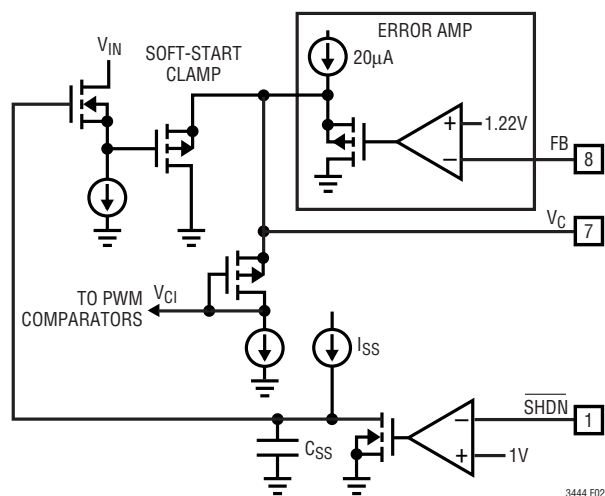

Figure 2. Soft-Start Circuitry

## OPERATION

### Buck-Boost Four-Switch Control

Figure 3 shows a simplified diagram of how the four internal switches are connected to the inductor,  $V_{IN}$ ,  $V_{OUT}$  and GND. Figure 4 shows the regions of operation for the LTC3444 as a function of the internal control voltage,  $V_{CI}$ . Depending on the control voltage, the LTC3444 will operate in either buck, buck-boost or boost mode. The  $V_{CI}$

voltage is a level shifted voltage from the output of the error amp ( $V_C$  pin) (see Figure 2). The four power switches are properly phased so the transfer between operating modes is continuous, smooth and transparent to the user. The buck-boost region is reached when  $V_{IN}$  approaches  $V_{OUT}$ . The conduction time of the four switch region is typically 125ns. The three operating modes of the four switch buck-boost converter are described below. Please refer to Figures 3 and 4.

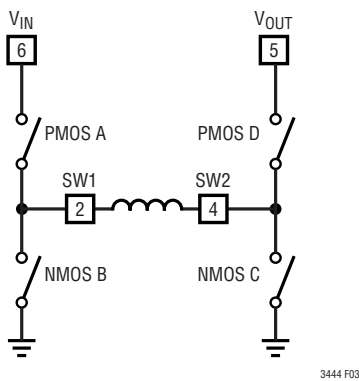

Figure 3. Simplified Diagram of Output Switches

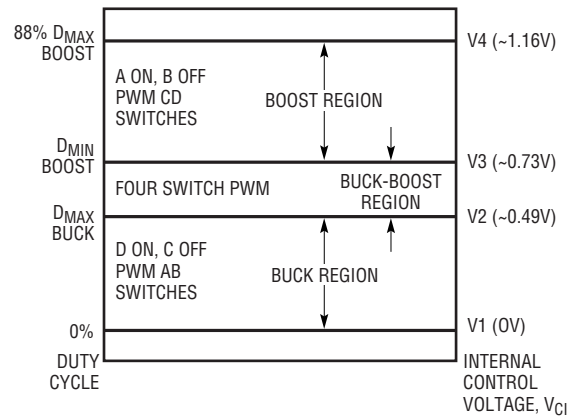

Figure 4. Switch Control vs Internal Control Voltage,  $V_{CI}$

## OPERATION

### Buck Region ( $V_{IN} > V_{OUT}$ )

Switch D is always on and switch C is always off during this mode. When the internal control voltage,  $V_{CI}$ , is above voltage V1, Switch A is on. During the off time of switch A, synchronous switch B turns on for the remainder of the time. Switches A and B will alternate similar to a typical synchronous buck regulator. As the control voltage increases, the duty cycle of switch A increases until the maximum duty cycle of the converter in buck mode reaches  $D_{MAX\_BUCK}$ , given by:

$$D_{MAX\_BUCK} = 100\% - D_{4SW}$$

where  $D_{4SW}$  = duty cycle % of the four switch range.

$$D_{4SW} = (125ns \cdot f) \cdot 100\%$$

where  $f$  = operating frequency, Hz.

Beyond this point the “four switch,” or Buck-Boost region is reached.

### Buck-Boost or Four Switch ( $V_{IN} \sim V_{OUT}$ )

When the internal control voltage,  $V_{CI}$ , is above voltage V2, but below V3, switch pair AD remain on for duty cycle  $D_{MAX\_BUCK}$ , and the switch pair AC begins to phase in. As switch pair AC phases in, switch pair BD phases out accordingly. When the  $V_{CI}$  voltage reaches the edge of the buck-boost range, at voltage V3, the AC switch pair completely phase out the BD pair, and the boost phase begins at duty cycle  $D_{4SW}$ . The input voltage,  $V_{IN}$ , where the four switch region begins is given by:

$$V_{IN} = \frac{V_{OUT}}{1 - (125ns \cdot f)} V$$

The point at which the four switch region ends is given by:

$$V_{IN} = V_{OUT}(1 - D) = V_{OUT}(1 - 125ns \cdot f) V$$

## OPERATION

### Boost Region ( $V_{IN} < V_{OUT}$ )

Switch A is always on and switch B is always off during this mode. When the internal control voltage,  $V_{CI}$ , is above voltage  $V_3$ , switch pair CD will alternately switch to provide a boosted output voltage. This operation is typical to a synchronous boost regulator. The maximum duty cycle of the converter is limited to 82% typical and is reached when  $V_{CI}$  is above  $V_4$ .

### CONTROLLING THE OUTPUT VOLTAGE

The output voltage is controlled via a summing resistor input at the feedback (FB) resistive divider string. Refer to Figure 1. The output voltage has an inverse relation to the control voltage as shown in Figure 5. The resistor values are dependent on the desired output voltage range and the

control voltage range. When using the internal loop compensation,  $V_C = GND$ , **R1 must be 340k**. For external compensation R1 should be chosen first and R2 and R3 calculated from the following equations.

The resistor values are given by:

$$R3 = \frac{(V_{CON(MAX)} - V_{CON(MIN)})}{V_{O(MAX)} - V_{O(MIN)}} \cdot R1 \Omega$$

$$R2 = \frac{1.22}{\frac{(V_{CON(MAX)} - 1.22)}{R3} - \frac{(1.22 - V_{O(MIN)})}{R1}} \Omega$$

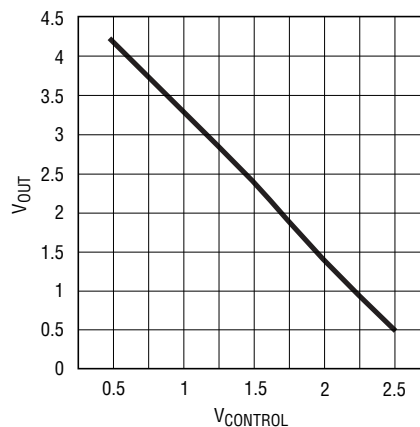

3444 G01

Figure 5.  $V_{OUT}$  vs  $V_{CONTROL}$  with  $R1 = 340k$ ,  $R2 = 249k$ , and  $R3 = 182k$ ,  $V_{CONTROL} = 0.5V$  to  $2.5V$

## OPERATION

Table 1. Shows some typical resistor value combinations for several  $V_{\text{CONTROL}}$  vs  $V_{\text{OUT}}$  voltage ranges. One percent (1%) resistor tolerances were assumed.

**Table 1. Typical Resistor Values for  $V_{\text{OUT}}$  vs  $V_{\text{CONTROL}}$**

$V_{\text{CONTROL}}$ (V)		$V_{\text{OUT}}$ (V)		RESISTANCE (k $\Omega$ )		
MIN	MAX	MIN	MAX	R1	R2	R3
0.35	2.4	0.8	4.2	340	271	205
0.35	2.5	0.5	5.0	340	210	162
0.8	2.35	0.8	4.2	340	200	154
0.5	2.5	0.5	4.2	340	249	182

## COMPONENT SELECTION

### Recommended Component Placement

Figure 6. Shows a recommended component placement. Traces carrying high current should be made short and wide. Trace area at FB and  $V_{\text{C}}$  pins should be minimized. Lead lengths to the battery should be kept short.  $V_{\text{OUT}}$  and  $V_{\text{IN}}$  ceramic capacitors should be placed close to the IC pins. Multiple vias should be used between layers.

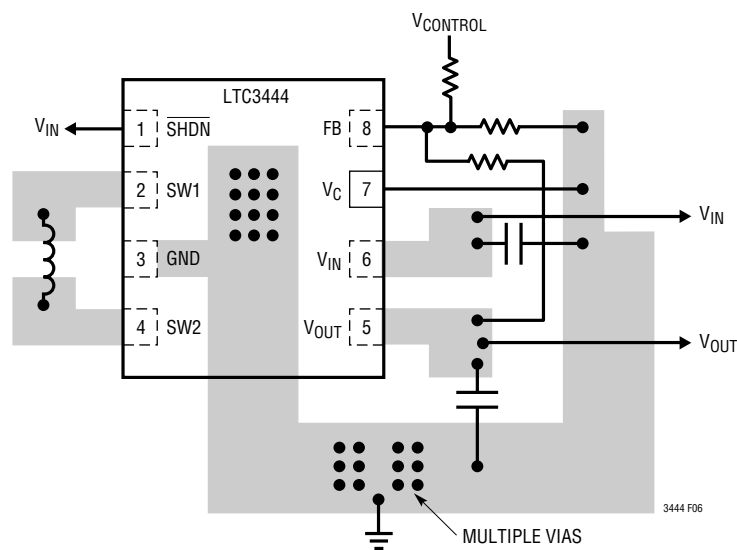

**Figure 6. Recommended Component Placement**

## OPERATION

### Inductor Selection

The high frequency operation of the LTC3444 allows the use of small surface mount inductors. The internal loop compensation is designed to work with a 2.2μH inductor (1.5μH for  $V_{IN} < 3.1V$ ). The 2.2μH inductor was selected to optimize the transient response to the control input. The use of a 2.2μH inductor pushes out the right half plane (RHP) zero frequency and allows the loop crossover to occur at frequencies higher than the output L-C double pole.

For external compensation the inductor selection is based on the desired inductor ripple current. The inductor ripple current is typically set to 20% to 40% of the average inductor current. Increased inductance results in lower ripple current, however, higher inductance pulls in the RHP zero frequency and limits the maximum crossover frequency possible. Refer to Closing the Feedback Loop for more information on the RHP zero. For a given ripple the inductance terms are given as follows:

$$L_{\text{BOOST}} > \frac{V_{\text{IN(MIN)}} \cdot (V_{\text{OUT}} - V_{\text{IN(MIN)}})}{f \cdot I_{\text{OUT(MAX)}} \cdot \Delta I_L \cdot V_{\text{OUT}}} \text{H}$$

$$L_{\text{BUCK}} > \frac{V_{\text{OUT}} \cdot (V_{\text{IN(MAX)}} - V_{\text{OUT}})}{f \cdot I_{\text{OUT(MAX)}} \cdot \Delta I_L \cdot V_{\text{IN(MAX)}}} \text{H}$$

where  $f$  = operating frequency, Hz

$\Delta I_L$  = inductor ripple current, A

$V_{\text{IN(MIN)}}$  = minimum input voltage, V

$V_{\text{IN(MAX)}}$  = maximum input voltage, V

$V_{\text{OUT}}$  = output voltage, V

$I_{\text{OUT(MAX)}}$  = maximum output load current

In most cases, the boost configuration will be used to determine the minimum inductance allowed for a given ripple current.

For high efficiency, choose a ferrite inductor with a high frequency core material to reduce core losses. The inductor should have low ESR (equivalent series resistance) to reduce the  $I^2R$  losses, and must be able to handle the peak inductor current without saturating. To minimize radiated noise, use a shielded inductor. See Table 2 for a suggested list of inductor suppliers.

**Table 2. Inductor Vendor Information**

SUPPLIER	PHONE	FAX	WEB SITE
Coilcraft	(847) 639-6400	(847) 639-1469	www.coilcraft.com
CoEv Magnetics	(800) 227-7040	(650) 361-2508	www.circuitprotection.com/magnetics.asp
COOPER Bussmann	(636) 394-2877	1-800-544-2570	www.coooperET.com
Murata	(814) 237-1431 (800) 831-9172	(814) 238-0490	www.murata.com
Sumida	USA: (847) 956-0666 Japan: 81(3) 3607-5111	USA: (847) 956-0702 Japan: 81(3) 3607-5144	www.sumida.com
TDK	(847) 803-6100	(847) 803-6296	www.component.tdk.com
TOKO	(847) 297-0070	(847) 699-7864	www.tokoam.com

## OPERATION

### Output Capacitor Selection

A 4.7 $\mu$ F, X5R or X7R type ceramic capacitor should be used when using the internal loop compensation. When using external compensation, larger values of output capacitance can be used, however, larger output capacitance will increase the time needed to slew the output voltage as required in typical WCDMA applications. The bulk value of the output filter capacitor is set to reduce the ripple due to charge into the capacitor each cycle. The steady state ripple due to charge is given by:

$$\% \text{ RIPPLE\_BOOST} = \frac{I_{\text{OUT}} \cdot (V_{\text{OUT}} - V_{\text{IN(MIN)}}) \cdot 100}{C_{\text{OUT}} \cdot V_{\text{OUT}}^2 \cdot f} \%$$

$$\% \text{ RIPPLE\_BUCK} = \frac{I_{\text{OUT(MAX)}} \cdot (V_{\text{IN(MAX)}} - V_{\text{OUT}}) \cdot 100}{C_{\text{OUT}} \cdot V_{\text{IN(MAX)}} \cdot V_{\text{OUT}} \cdot f} \%$$

where  $C_{\text{OUT}}$  = output filter capacitor in farads  
 $f$  = switching frequency in Hz.

In a typical application the output capacitance may be many times larger than that calculated above in order to handle the transient load response requirements of the converter. For a rule of thumb, the ratio of the operating frequency to the unity-gain bandwidth of the converter is the amount the output capacitance will have to increase from the above calculations in order to maintain the desired transient response. However, in WCDMA applications the output capacitance should be kept at a minimum to maximize the output slew rate. Refer to the Loop Compensation Networks section of this datasheet.

The other component of ripple is due to the ESR (equivalent series resistance) of the output capacitor. Low ESR capacitors should be used to minimize output voltage ripple. For surface mount applications, Taiyo Yuden or TDK ceramic capacitors, AVX TPS series tantalum capacitors or Sanyo POSCAP are recommended. See Table 3 for contact information.

Ceramic output capacitors should use case size 1206 or larger. Smaller case sizes have a larger voltage coefficient that can greatly reduce the output capacitance value at higher output voltages.

### Input Capacitor Selection

Since the  $V_{\text{IN}}$  pin is the supply voltage for the LTC3444, as well as the input to the power stage of the converter, it is recommended to place at least a 4.7 $\mu$ F, X5R or X7R ceramic bypass capacitor close to the  $V_{\text{IN}}$  and GND pins. It is also important to minimize any stray resistance from the converter to the battery or other power source.

**Table 3. Capacitor Vendor Information**

SUPPLIER	PHONE	FAX	WEB SITE
AVX	(803) 448-9411	(803) 448-1943	www.avxcorp.com
Sanyo	(619) 661-6322	(619) 661-1055	www.sanyovideo.com
Taio Yuden	(408) 573-4150	(408) 573-4159	www.t-yuden.com
TDK	(847) 803-6100	(847) 803-6296	www.component.tdk.com

## OPERATION

### Optional Schottky Diodes

Schottky diodes across the synchronous switches B and D are not required, but provide a lower drop during the break-before-make time (typically 15ns) of the NMOS to PMOS transition, improving efficiency. Use a surface mount Schottky diode such as an MBRM120T3 or equivalent. Do not use ordinary rectifier diodes, since the slow recovery times will compromise efficiency.

### Closing the Feedback Loop

The LTC3444 incorporates voltage mode PWM control. The control to output gain varies with operation region (buck, boost, buck-boost), but is usually ~20dB. The output filter exhibits a double pole response, as given by:

$$f_{\text{FILTER\_POLE}} = \frac{1}{2 \cdot \pi \cdot \sqrt{L \cdot C_{\text{OUT}}}} \text{ Hz}$$

(in buck mode)

$$f_{\text{FILTER\_POLE}} = \frac{V_{\text{IN}}}{2 \cdot V_{\text{OUT}} \cdot \pi \cdot \sqrt{L \cdot C_{\text{OUT}}}} \text{ Hz}$$

(in boost mode)

where L is in Henries and  $C_{\text{OUT}}$  is in farads.

The output filter zero is given by:

$$f_{\text{FILTER\_ZERO}} = \frac{1}{2 \cdot \pi \cdot R_{\text{ESR}} \cdot C_{\text{OUT}}} \text{ Hz}$$

where  $R_{\text{ESR}}$  is the equivalent series resistance of the output cap.

A troublesome problem when operating in boost mode is dealing with the right-half plane zero (RHP), given by:

$$f_{\text{RHPZ}} = \frac{V_{\text{IN}}^2}{2 \cdot \pi \cdot I_{\text{OUT}} \cdot L \cdot V_{\text{OUT}}} \text{ Hz}$$

The RHP zero has a +20dB/dec gain typical of a zero but the  $-90^\circ$  phase lag of a pole. This causes the loop gain to flatten out while the phase margin decreases. The only way to combat a RHP zero is to roll off the loop well before the RHP zero frequency.

### LOOP COMPENSATION NETWORKS

A simple Type I compensation network, refer to Figure 7, can be incorporated to stabilize the loop, but at a cost of reduced bandwidth and slower transient response. To ensure proper phase margin using Type I compensation, the loop must be crossed over at least a decade before the output LC double pole frequency. The unity-gain frequency of the error amplifier with the Type I compensation is given by:

$$f_{\text{UG}} = \frac{1}{2 \cdot \pi \cdot R1 \cdot C2} \text{ Hz}$$

WCDMA applications demand an improved transient response to the input control voltage. In other applications, the output capacitor can be increased to meet help meet the load transient requirements.

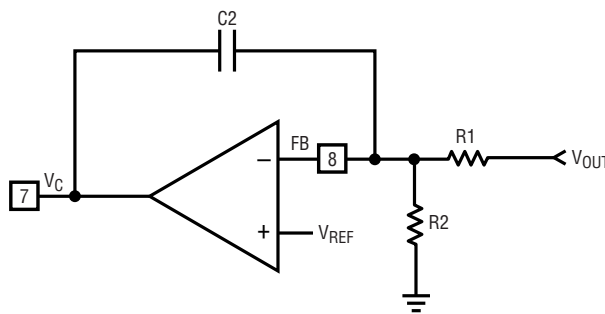

3444 F07

Figure 7. Error Amplifier with Type I Compensation



## OPERATION

However, due to the output voltage slewing requirements found in WCDMA applications the output filter capacitor must be minimized. To maximize the transient response, while minimizing the output capacitance, a higher bandwidth, Type III compensation is required. A Type III compensation network, refer to Figure 8, has a double zero to cancel the double pole of the output LC filter and a double pole to compensate for the ESR zero and RHP zero of the boost topology. In addition to the double poles, the Type III network also has a single pole at DC. The Type III compensation provides a maximum 135° phase boost and allows the loop crossover to occur at frequencies higher than the output LC. Refer to Figure 9. Referring to Figure 8, the location of the poles and zeros are given by: Assume  $C_2 \gg C_3$ ,  $R_1 \gg R_4$ .

$$f_{\text{POLE1}} \cong \frac{1}{2 \cdot \pi \cdot R5 \cdot C3} \text{Hz}$$

$$f_{\text{POLE2}} = \frac{1}{2 \cdot \pi \cdot R4 \cdot C1} \text{Hz}$$

$$f_{\text{ZERO1}} = \frac{1}{2 \cdot \pi \cdot R1 \cdot C1} \text{Hz}$$

$$f_{\text{ZERO2}} = \frac{1}{2 \cdot \pi \cdot R5 \cdot C2} \text{Hz}$$

And the unity gain frequency ( $f_{\text{UG}}$ ) of the Type III compensation is given by:

$$f_{\text{UG}} = \frac{1}{2 \cdot \pi \cdot R1 \cdot C2} \text{Hz}$$

where resistance is in ohms and capacitance is in farads. Note: Bias resistor, R2, does not affect the Pole/Zero placement.

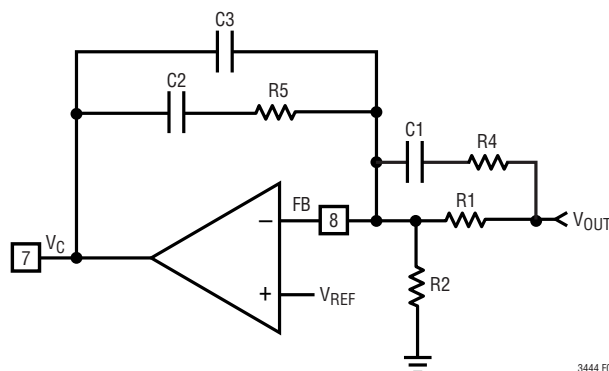

Figure 8, Error Amplifier with Type III Compensation

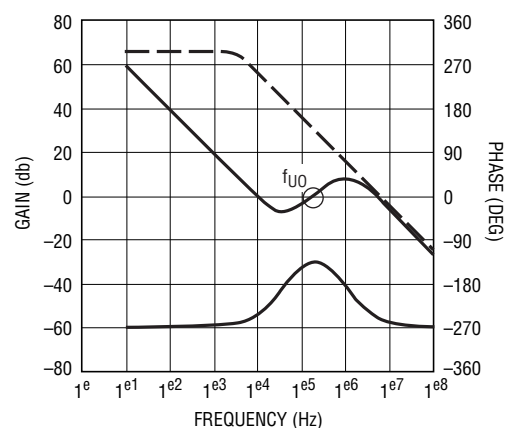
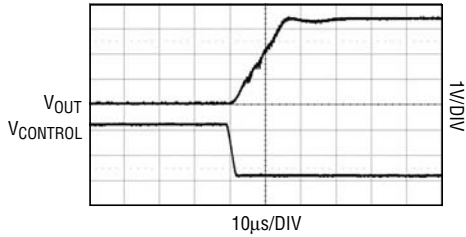

Figure 9. Frequency Response for LTC3444 Error Amplifier with a Typical Type III Compensation Network

## TYPICAL APPLICATIONS

### Example of Internal Compensation Transient Response for a Command Voltage Change

LTC3444 Dynamic Response



$V_{IN} = 3.6V$ ,  $V_{OUT} = 0.8V$  TO  $4.2V$   
 $V_{CONTROL} = 2.36V$  TO  $0.28V$ ,  $I_{LOAD} = 100mA$

3444 G16a

LTC3444 Dynamic Response

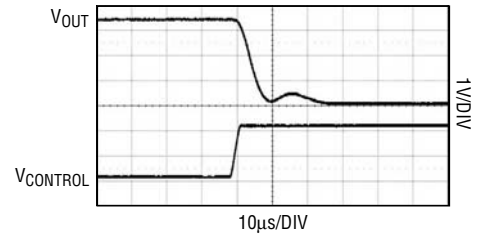

$V_{IN} = 3.6V$ ,  $V_{OUT} = 4.2V$  TO  $0.8V$   
 $V_{CONTROL} = 0.28V$  TO  $2.36V$ ,  $I_{LOAD} = 100mA$

3444 G17

### Internally Compensated WCDMA Application. Single Cell, 2.7V to 4.2V Input, 0.8V to 4.2V at 400mA Output.

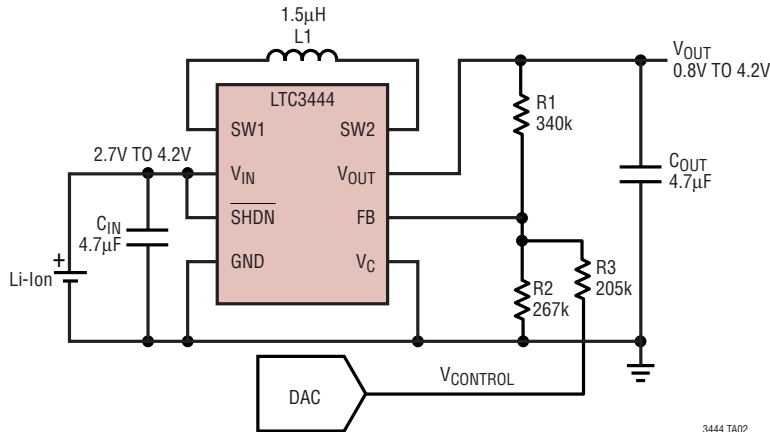

3444 TA02

$C_{IN}$  = MURATA:GRM31CR61C475K  
 $C_{OUT}$  = MURATA:GRM31CR61C475K  
 $L1$  = COOPER BUSSMAN SD12-2R2

# TYPICAL APPLICATIONS

**Single Li-Ion, 3.1V to 4.2V Input, 3.3V at 400mA Output with Internal Compensation**

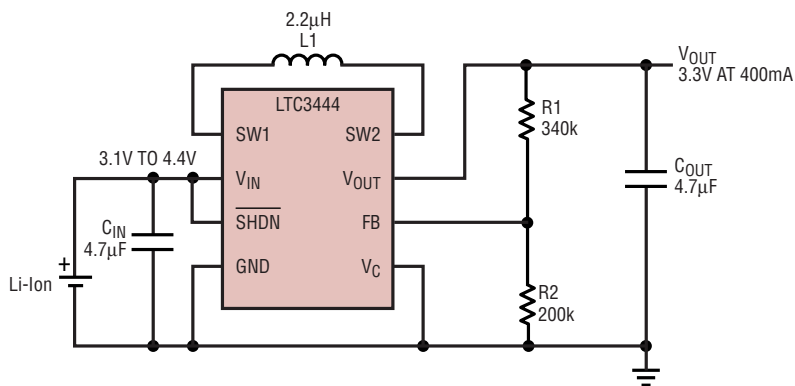

3444 TA04

C<sub>IN</sub> = MURATA:GRM31CR61C475K  
 C<sub>OUT</sub> = MURATA:GRM31CR61C475K  
 L1 = COOPER BUSSMAN SD12-2R2

# PACKAGE DESCRIPTION

**DD Package**  
**8-Lead Plastic DFN (3mm × 3mm)**  
 (Reference LTC DWG # 05-08-1698)

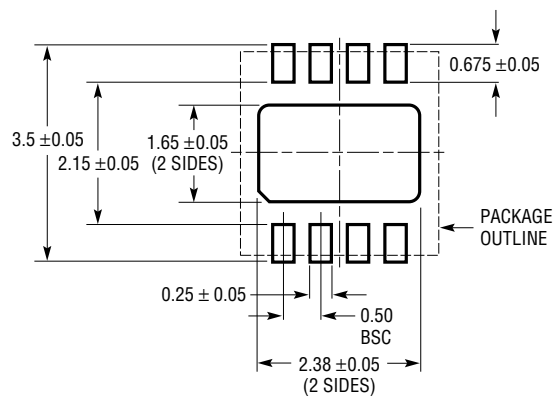

RECOMMENDED SOLDER PAD PITCH AND DIMENSIONS

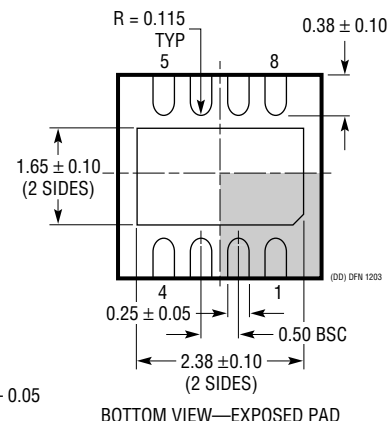
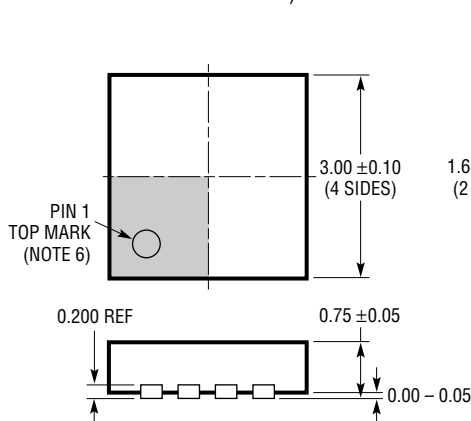

**NOTE:**

1. DRAWING TO BE MADE A JEDEC PACKAGE OUTLINE M0-229 VARIATION OF (WEED-1)
2. DRAWING NOT TO SCALE
3. ALL DIMENSIONS ARE IN MILLIMETERS
4. DIMENSIONS OF EXPOSED PAD ON BOTTOM OF PACKAGE DO NOT INCLUDE MOLD FLASH. MOLD FLASH, IF PRESENT, SHALL NOT EXCEED 0.15mm ON ANY SIDE

5. EXPOSED PAD SHALL BE SOLDER PLATED
6. SHADED AREA IS ONLY A REFERENCE FOR PIN 1 LOCATION ON TOP AND BOTTOM OF PACKAGE

## TYPICAL APPLICATION

Externally Compensated WCDMA Application. Single Cell,  
3.1V to 4.2V Input, 0.8V to 4.2V at 400mA Output.

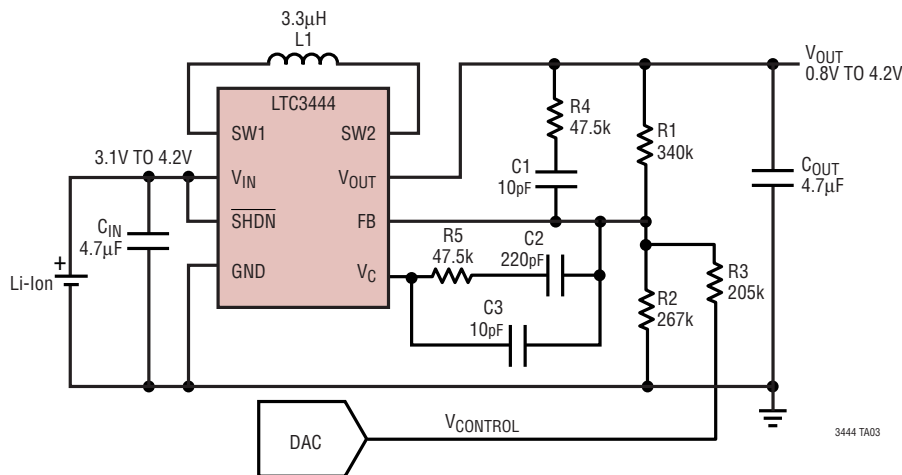

$C_{IN}$  = MURATA:GRM31CR61C475K  
 $C_{OUT}$  = MURATA:GRM31CR61C475K  
 $L1$  = COOPER BUSSMAN SD12-3R3

3444 TA03

## RELATED PARTS

PART NUMBER	DESCRIPTION	COMMENTS
LTC3403	1.5MHz, 600mA, Synchronous Step-Down Regulator with Bypass Transistor	96% Efficiency, $V_{IN}$ : 2.5V to 5V, $V_{OUT}$ : 0.3V to 3.5V, $I_{SD} < 1\mu A$ , (3mm × 3mm) DFN Package
LTC3408	1.5MHz, 600mA, Synchronous Step-Down Regulator with Bypass Transistor	96% Efficiency, $V_{IN}$ : 2.5V to 5V, $V_{OUT}$ : 0.3V to 3.5V, $I_{SD} < 1\mu A$ , (3mm × 3mm) DFN Package
LTC3440	Up to 2MHz, 600µA, Synchronous Buck-Boost DC/DC Converter	95% Efficiency, $V_{IN}$ : 2.5V to 5.5V, $V_{OUT(MIN)} = 2.5V$ , $I_{SD} < 1\mu A$ , $I_Q = 25\mu A$ , 10-Lead MS Package
LTC3441	1MHz, 1.2A, Synchronous Buck-Boost DC/DC Converter	95% Efficiency, $V_{IN}$ : 2.5V to 5.5V, $V_{OUT(MIN)} = 2.5V$ , $I_{SD} < 1\mu A$ , $I_Q = 25\mu A$ , 12-Lead (4mm × 3mm) DFN Package
LTC3442	Up to 2MHz, 1.2A, Synchronous Buck-Boost DC/DC Converter	95% Efficiency, $V_{IN}$ : 2.5V to 5.5V, $V_{OUT(MIN)} = 2.5V$ , $I_{SD} < 1\mu A$ , $I_Q = 25\mu A$ , 12-Lead (4mm × 3mm) DFN Package
LTC3443	600MHz, 1.2A Synchronous Buck-Boost DC/DC Converter	95% Efficiency, $V_{IN}$ : 2.5V to 5.5V, $V_{OUT(MIN)} = 2.5V$ , $I_{SD} < 1\mu A$ , $I_Q = 25\mu A$ , 12-Lead (4mm × 3mm) DFN Package

3444fb