

FEATURES

- Up to 92% Efficiency
- Generates 3.3V at 100mA from a Single AA Cell
- Low Start-Up Voltage: 0.85V
- V_{OUT} Connected to V_{IN} in Shutdown
- Internal Synchronous Rectifier
- 2.5V to 5V Output Range
- Automatic Burst Mode[®] Operation
- Logic Controlled Shutdown ($< 1\mu A$)
- Antiringing Control Minimizes EMI
- Tiny External Components
- Low Profile (1mm) SOT-23 Package

APPLICATIONS

- Pagers
- MP3 Players
- Digital Cameras
- LCD Bias Supplies
- Handheld Instruments
- Wireless Handsets
- GPS Receivers

DESCRIPTION

The LTC[®]3400-1 is a synchronous, fixed frequency, step-up DC/DC converter delivering high efficiency in a 6-lead ThinSOT[™] package. Capable of supplying 3.3V at 100mA from a single AA cell input, the device contains an internal NMOS switch and PMOS synchronous rectifier.

A switching frequency of 1.2MHz minimizes solution footprint by allowing the use of tiny, low profile inductors and ceramic capacitors. The current mode PWM design is internally compensated, reducing external parts count. The LTC3400-1 features automatic shifting to power saving Burst Mode operation at light loads. In shutdown, V_{OUT} and V_{IN} are connected, which allows the input battery to be used for backup power. The LTC3400-1 features low shutdown current of under $1\mu A$.

The LTC3400-1 is offered in the low profile (1mm) SOT-23 package.

LTC, LT and Burst Mode are registered trademarks of Linear Technology Corporation. ThinSOT is a trademark of Linear Technology Corporation.

US Patent Numbers 5,481,178; 6,580,258; 6,304,066; 6,127,815; 6,498,466; 6,611,131.

TYPICAL APPLICATION

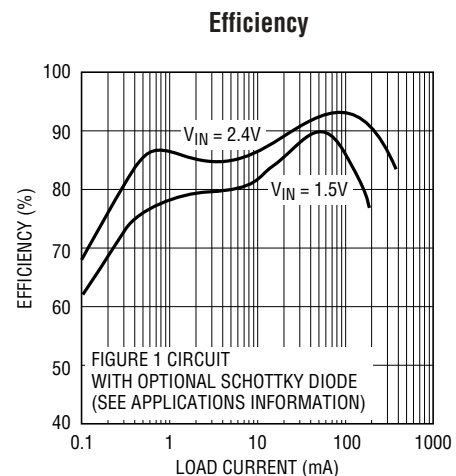
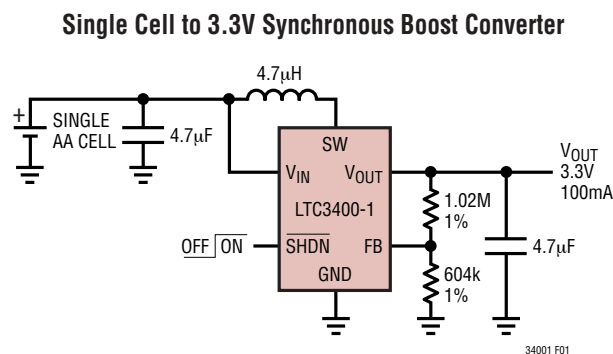

ABSOLUTE MAXIMUM RATINGS

(Note 1)

V_{IN} Voltage	-0.3V to 6V
SW Voltage	
DC	-0.3V to 6V
Pulsed (<100ns)	-0.3V to 7V
SHDN, FB Voltage	-0.3V to 6V
V_{OUT}	-0.3V to 6V
Operating Temperature Range (Note 2) ..	-30°C to 85°C
Storage Temperature Range	-65°C to 125°C
Lead Temperature (Soldering, 10 sec)	300°C

PACKAGE/ORDER INFORMATION

	ORDER PART NUMBER
	LTC3400ES6-1
	S6 PART MARKING
	LTBJM

Consult LTC Marketing for parts specified with wider operating temperature ranges.

ELECTRICAL CHARACTERISTICS

The ● denotes the specifications which apply over the full operating temperature range, otherwise specifications are at $T_A = 25^\circ\text{C}$. $V_{IN} = 1.2\text{V}$, $V_{OUT} = 3.3\text{V}$, unless otherwise specified.

PARAMETER	CONDITIONS	MIN	TYP	MAX	UNITS
Minimum Start-Up Voltage	$I_{LOAD} = 1\text{mA}$		0.85	1	V
Minimum Operating Voltage	$\overline{\text{SHDN}} = V_{IN}$ (Note 4)		0.5	0.65	V
Output Voltage Adjust Range		2.5		5	V
Feedback Voltage		● 1.192	1.23	1.268	V
Feedback Input Current	$V_{FB} = 1.25\text{V}$ (Note 3)		1		nA
Quiescent Current (Burst Mode Operation)	$V_{FB} = 1.4\text{V}$ (Note 5)		19	30	μA
Quiescent Current (Shutdown)	$V_{\overline{\text{SHDN}}} = 0\text{V}$, Not Including Switch Leakage, $V_{IN} = V_{OUT}$		0.01	1	μA
Quiescent Current (Active)	Measured On V_{OUT}		300	500	μA
NMOS Switch Leakage	$V_{SW} = 5\text{V}$		0.1	5	μA
PMOS Switch Leakage	$V_{SW} = 0\text{V}$ (Note 3)		0.1		μA
NMOS Switch On Resistance	$V_{OUT} = 3.3\text{V}$ $V_{OUT} = 5\text{V}$		0.35		Ω
			0.20		Ω
PMOS Switch On Resistance	$V_{OUT} = 3.3\text{V}$ $V_{OUT} = 5\text{V}$		0.45		Ω
			0.30		Ω
NMOS Current Limit		600	850		mA
Burst Mode Operation Current Threshold	(Note 3)		3		mA
Current Limit Delay to Output	(Note 3)		40		ns
Max Duty Cycle	$V_{FB} = 1.15\text{V}$	● 80	87		%
Switching Frequency		● 0.95	1.2	1.5	MHz
		● 0.85	1.2	1.5	MHz
SHDN Input High		1			V
SHDN Input Low				0.35	V
SHDN Input Current	$V_{\overline{\text{SHDN}}} = 5.5\text{V}$		0.01	1	μA

Note 1: Absolute Maximum Ratings are those values beyond which the life of a device may be impaired.

Note 2: The LTC3400-1 is guaranteed to meet performance specifications from 0°C to 70°C. Specifications over the -30°C to 85°C operating temperature range are assured by design, characterization and correlation with statistical process controls.

Note 3: Specification is guaranteed by design and not 100% tested in production.

Note 4: Minimum V_{IN} operation after start-up is only limited by the battery's ability to provide the necessary power as it enters a deeply discharged state.

Note 5: Burst Mode operation I_Q is measured at V_{OUT} . Multiply this value by V_{OUT}/V_{IN} to get the equivalent input (battery) current.

TYPICAL PERFORMANCE CHARACTERISTICS

Output Load Burst Mode Threshold vs V_{IN}

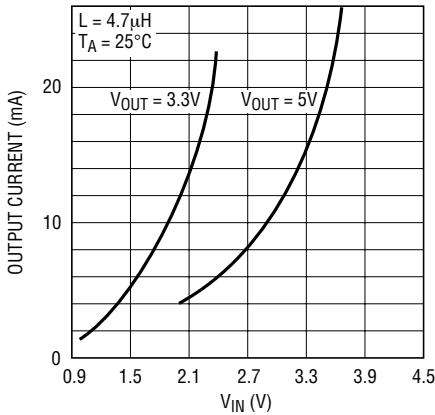

3400 G01

V_{OUT} vs Temperature

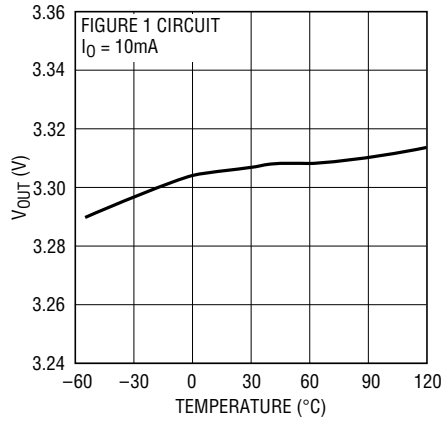

3400 G02

Minimum Start-Up Voltage vs Load Current

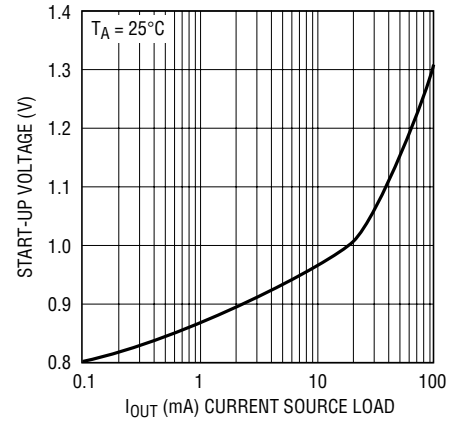

3400 G03

No Load Battery Current vs V_{BATT}

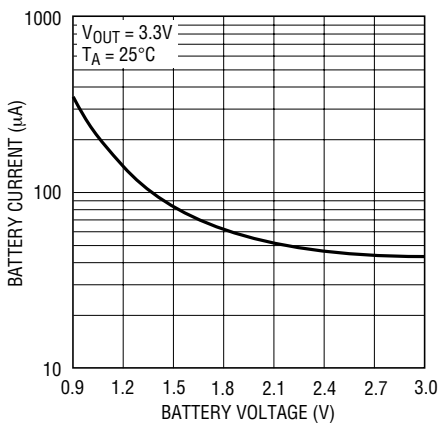

3400 G04

Normalized Oscillator Frequency vs Temperature

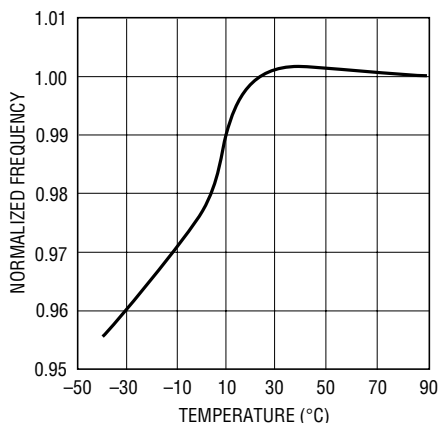

3400 G05

SW Pin Antiringing Operation

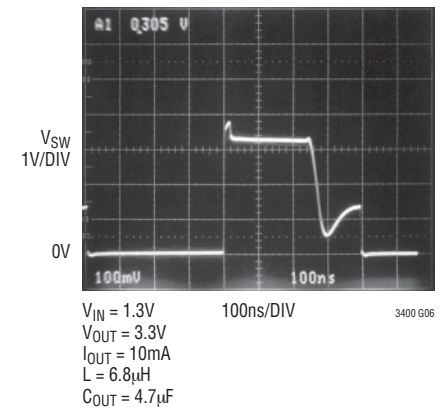

3400 G06

SW Pin Fixed Frequency, Continuous Inductor Current Operation

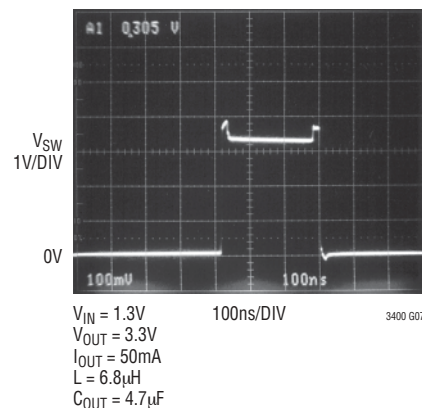

3400 G07

Fixed Frequency and Burst Mode Operation

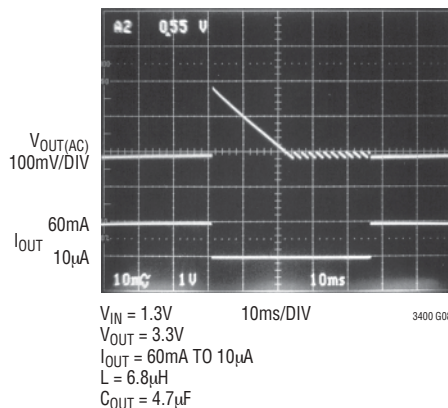

3400 G08

V_{OUT} Transient Response

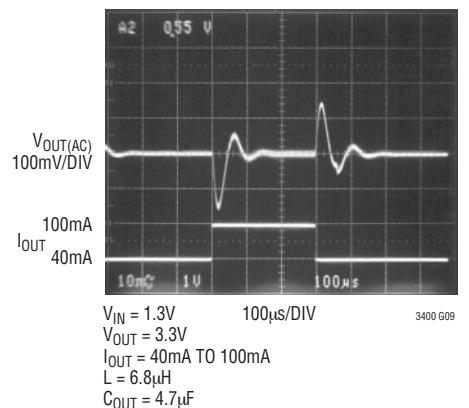

3400 G09

PIN FUNCTIONS

SW (Pin 1): Switch Pin. Connect inductor between SW and V_{IN} . Optional Schottky diode is connected between SW and V_{OUT} . Keep these PCB trace lengths as short and wide as possible to reduce EMI and voltage overshoot. If the inductor current falls to zero, or \overline{SHDN} is low, an internal 100Ω antiringing switch is connected from SW to V_{IN} to minimize EMI.

GND (Pin 2): Signal and Power Ground. Provide a short direct PCB path between GND and the (-) side of the output capacitor(s).

FB (Pin 3): Feedback Input to the g_m Error Amplifier. Connect resistor divider tap to this pin. The output voltage can be adjusted from 2.5V to 5V by:

$$V_{OUT} = 1.23V \cdot [1 + (R1/R2)]$$

SHDN (Pin 4): Logic Controlled Shutdown Input.

\overline{SHDN} = High: Normal free running operation, 1.2MHz typical operating frequency.

\overline{SHDN} = Low: Shutdown, quiescent current $< 1\mu A$. 100Ω connected between SW and V_{IN} . V_{IN} is connected to V_{OUT} through the internal P-channel MOSFET synchronous rectifier and external inductor.

Typically, \overline{SHDN} should be connected to V_{IN} through a 1M pull-up resistor.

V_{OUT} (Pin 5): Output Voltage Sense Input and Drain of the Internal Synchronous Rectifier MOSFET. Bias is derived from V_{OUT} . PCB trace length from V_{OUT} to the output filter capacitor(s) should be as short and wide as possible. V_{OUT} is connected to V_{IN} in shutdown through the internal P-channel MOSFET synchronous rectifier.

V_{IN} (Pin 6): Battery Input Voltage. The device gets its start-up bias from V_{IN} . Once V_{OUT} exceeds V_{IN} , bias comes from V_{OUT} . Thus, once started, operation is completely independent from V_{IN} . Operation is only limited by the output power level and the battery's internal series resistance.

BLOCK DIAGRAM

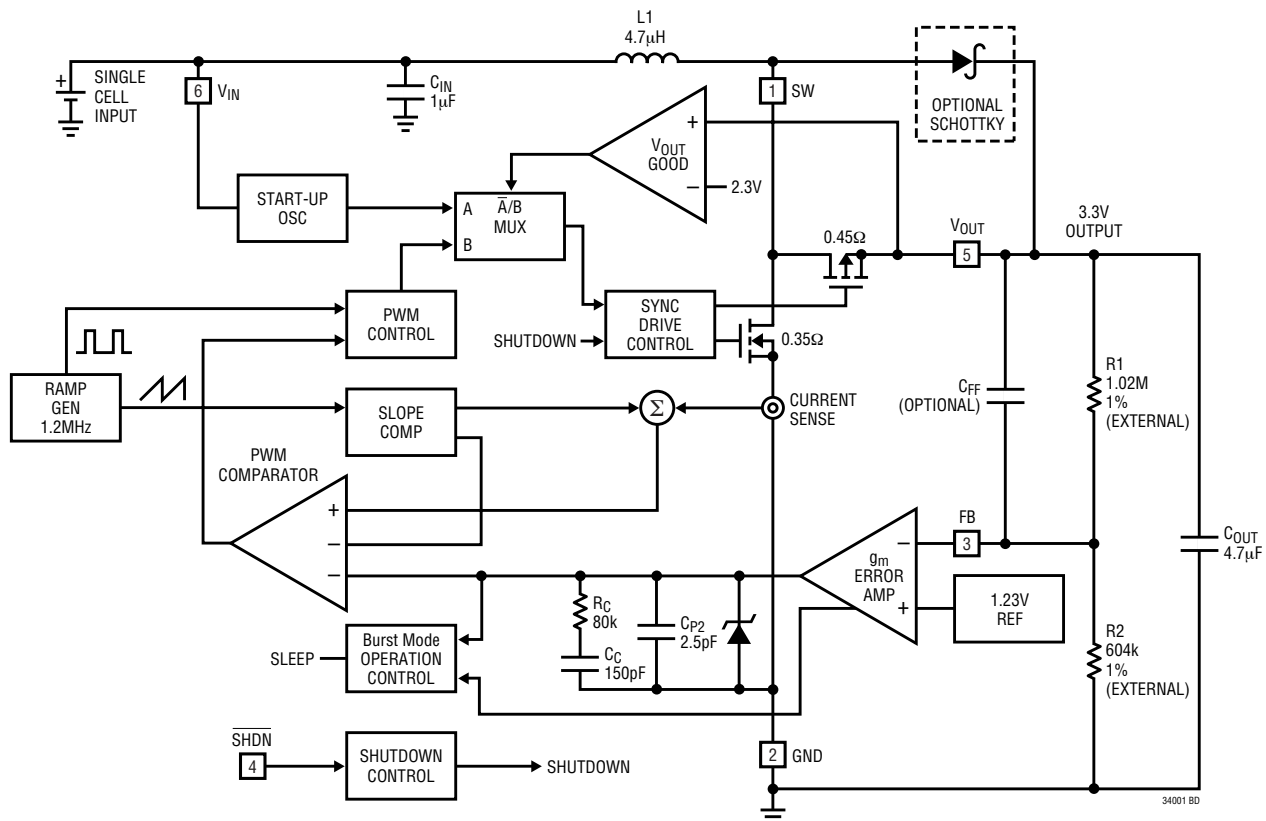

34001f

OPERATION

The LTC3400-1 is a 1.2MHz, synchronous boost converter housed in a 6-lead ThinSOT package. Able to operate from an input voltage below 1V, the device features fixed frequency, current mode PWM control for exceptional line and load regulation. With its low $R_{DS(ON)}$ and gate charge internal MOSFET switches, the device maintains high efficiency over a wide range of load current. Detailed descriptions of the three distinct operating modes follow. Operation can be best understood by referring to the Block Diagram.

Low Voltage Start-Up

The LTC3400-1 will start up at a typical V_{IN} voltage of 0.85V or higher. The low voltage start-up circuitry controls the internal NMOS switch up to a maximum peak inductor current of 850mA (typ), with an approximate 1.5 μ s off-time during start-up, allowing the device to start up into an output load. Once V_{OUT} exceeds 2.3V, the start-up circuitry is disabled and normal fixed frequency PWM operation is initiated. In this mode, the LTC3400-1 operates independent of V_{IN} , allowing extended operating time as the battery can droop to several tenths of a volt without affecting output voltage regulation. The limiting factor for the application becomes the ability of the battery to supply sufficient energy to the output.

Low Noise Fixed Frequency Operation

Oscillator: The frequency of operation is internally set to 1.2MHz.

Error Amp: The error amplifier is an internally compensated transconductance type (current output) with a transconductance (g_m) = 33 microsiemens. The internal 1.23V reference voltage is compared to the voltage at the FB pin to generate an error signal at the output of the error amplifier. A voltage divider from V_{OUT} to ground programs the output voltage via FB from 2.5V to 5V using the equation:

$$V_{OUT} = 1.23V \cdot [1 + (R1/R2)]$$

Current Sensing: A signal representing NMOS switch current is summed with the slope compensator. The summed signal is compared to the error amplifier output

to provide a peak current control command for the PWM. Peak switch current is limited to approximately 850mA independent of input or output voltage. The current signal is blanked for 40ns to enhance noise rejection.

Zero Current Comparator: The zero current comparator monitors the inductor current to the output and shuts off the synchronous rectifier once this current reduces to approximately 20mA. This prevents the inductor current from reversing in polarity improving efficiency at light loads.

Antiringing Control: The antiringing control circuitry prevents high frequency ringing of the SW pin as the inductor current goes to zero by damping the resonant circuit formed by L and C_{SW} (capacitance on SW pin).

Burst Mode Operation

Portable devices frequently spend extended time in low power or standby mode, only switching to high power drain when specific functions are enabled. In order to improve battery life in these types of products, high power converter efficiency needs to be maintained over a wide output power range. In addition to its high efficiency at moderate and heavy loads, the LTC3400-1 includes automatic Burst Mode operation that improves efficiency of the power converter at light loads. Burst mode operation is initiated if the output load current falls below an internally programmed threshold (see Typical Performance graph, Output Load Burst Mode Threshold vs V_{IN}). Once initiated, the Burst Mode operation circuitry shuts down most of the device, only keeping alive the circuitry required to monitor the output voltage. This is referred to as the sleep state. In sleep, the LTC3400-1 draws only 19 μ A from the output capacitor, greatly enhancing efficiency. When the output voltage has drooped approximately 1% from nominal, the LTC3400-1 wakes up and commences normal PWM operation. The output capacitor recharges and causes the LTC3400-1 to reenter sleep if the output load remains less than the sleep threshold. The frequency of this intermittent PWM or burst operation is proportional to load current; that is, as the load current drops further below the burst threshold, the LTC3400-1 turns on less frequently. When the load current increases

OPERATION

above the burst threshold, the LTC3400-1 will resume continuous PWM operation seamlessly. Referring to the Block Diagram, an optional capacitor (C_{FF}) between V_{OUT} and FB in some circumstances can reduce the peak-to-

peak V_{OUT} ripple and input quiescent current during Burst Mode operation. Typical values for C_{FF} range from 15pF to 220pF.

APPLICATIONS INFORMATION

PCB LAYOUT GUIDELINES

The high speed operation of the LTC3400-1 demands careful attention to board layout. You will not get advertised performance with careless layout. Figure 1 shows the recommended component placement. A large ground pin copper area will help to lower the chip temperature. A multilayer board with a separate ground plane is ideal, but not absolutely necessary.

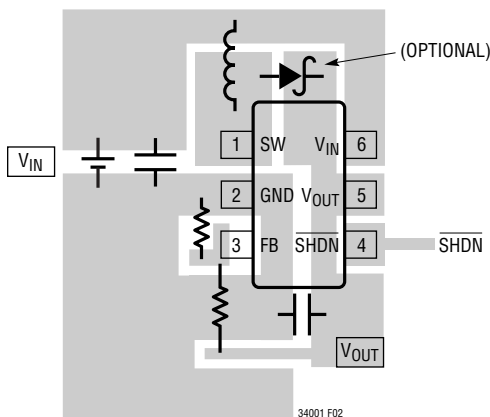

RECOMMENDED COMPONENT PLACEMENT. TRACES CARRYING HIGH CURRENT ARE DIRECT. TRACE AREA AT FB PIN IS SMALL. LEAD LENGTH TO BATTERY IS SHORT

Figure 1. Recommended Component Placement for Single Layer Board

COMPONENT SELECTION

Inductor Selection

The LTC3400-1 can utilize small surface mount and chip inductors due to its fast 1.2MHz switching frequency. A minimum inductance value of 3.3 μ H is necessary for 3.6V and lower voltage applications and 4.7 μ H for output voltages greater than 3.6V. Larger values of inductance

will allow greater output current capability by reducing the inductor ripple current. Increasing the inductance above 10 μ H will increase size while providing little improvement in output current capability.

The approximate output current capability of the LTC3400-1 versus inductance value is given in the equation below and illustrated graphically in Figure 2.

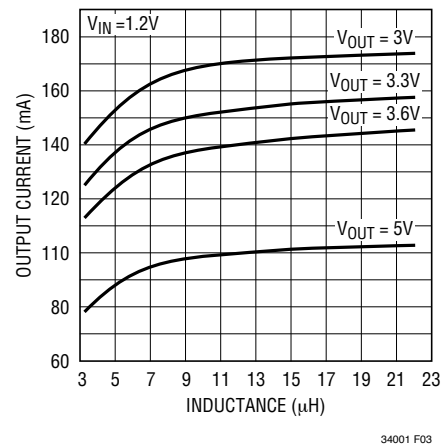

Figure 2. Maximum Output Current vs Inductance Based On 90% Efficiency

$$I_{OUT(MAX)} = \eta \cdot \left(I_P - \frac{V_{IN} \cdot D}{f \cdot L \cdot 2} \right) \cdot (1 - D)$$

where:

η = estimated efficiency

I_P = peak current limit value (0.6A)

V_{IN} = input (battery) voltage

D = steady-state duty ratio = $(V_{OUT} - V_{IN})/V_{OUT}$

f = switching frequency (1.2MHz typical)

L = inductance value

APPLICATIONS INFORMATION

The inductor current ripple is typically set for 20% to 40% of the maximum inductor current (I_P). High frequency ferrite core inductor materials reduce frequency dependent power losses compared to cheaper powdered iron types, improving efficiency. The inductor should have low ESR (series resistance of the windings) to reduce the I^2R power losses, and must be able to handle the peak inductor current without saturating. Molded chokes and some chip inductors usually do not have enough core to support the peak inductor currents of 850mA seen on the LTC3400-1. To minimize radiated noise, use a toroid, pot core or shielded bobbin inductor. See Table 1 for some suggested components and suppliers.

Table 1. Recommended Inductors

PART	L (μ H)	MAX DCR m Ω	HEIGHT (mm)	VENDOR
CDRH5D18-4R1	4.1	57	2.0	Sumida (847) 956-0666 www.sumida.com
CDRH5D18-100	10	124	2.0	
CDRH3D16-4R7	4.7	105	1.8	
CDRH3D16-6R8		170	1.8	
CR43-4R7	4.7	109	3.5	
CR43-100	10	182	3.5	
CMD4D06-4R7MC	4.7	216	0.8	
CMD4D06-3R3MC	3.3	174	0.8	
DS1608-472	4.7	60	2.9	Coilcraft (847) 639-6400 www.coilcraft.com
DS1608-103	10	75	2.9	
DO1608C-472	4.7	90	2.9	
D52LC-4R7M	4.7	84	2.0	Toko (408) 432-8282 www.tokoam.com
D52LC-100M	10	137	2.0	
LQH3C4R7M24	4.7	195	2.2	Murata www.murata.com

Output and Input Capacitor Selection

Low ESR (equivalent series resistance) capacitors should be used to minimize the output voltage ripple. Multilayer ceramic capacitors are an excellent choice as they have

extremely low ESR and are available in small footprints. A 2.2 μ F to 10 μ F output capacitor is sufficient for most applications. Larger values up to 22 μ F may be used to obtain extremely low output voltage ripple and improve transient response. An additional phase lead capacitor may be required with output capacitors larger than 10 μ F to maintain acceptable phase margin. X5R and X7R dielectric materials are preferred for their ability to maintain capacitance over wide voltage and temperature ranges.

Low ESR input capacitors reduce input switching noise and reduce the peak current drawn from the battery. It follows that ceramic capacitors are also a good choice for input decoupling and should be located as close as possible to the device. A 4.7 μ F input capacitor is sufficient for virtually any application. Larger values may be used without limitations. Table 2 shows a list of several ceramic capacitor manufacturers. Consult the manufacturers directly for detailed information on their entire selection of ceramic parts.

Table 2. Capacitor Vendor Information

SUPPLIER	PHONE	WEBSITE
AVX	(803) 448-9411	www.avxcorp.com
Murata	(714) 852-2001	www.murata.com
Taiyo Yuden	(408) 573-4150	www.t-yuden.com

Output Diode

Use a Schottky diode such as an MBR0520L, PMEG2010EA, 1N5817 or equivalent if the converter output voltage is 4.5V or greater. The Schottky diode carries the output current for the time it takes for the synchronous rectifier to turn on. Do not use ordinary rectifier diodes, since the slow recovery times will compromise efficiency. A Schottky diode is also strongly recommended for output voltages below 4.5V, and will increase converter efficiency by 2% to 3%.

TYPICAL APPLICATIONS

Single Cell to 3.3V Synchronous Boost Converter with Load Disconnect in Shutdown

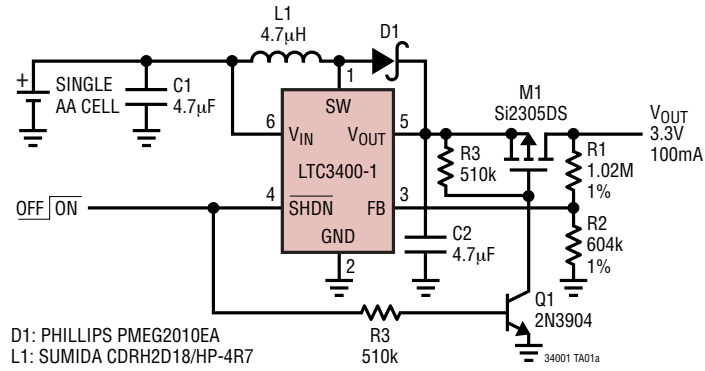

TYPICAL APPLICATIONS

Single Lithium Cell to 5V, 250mA

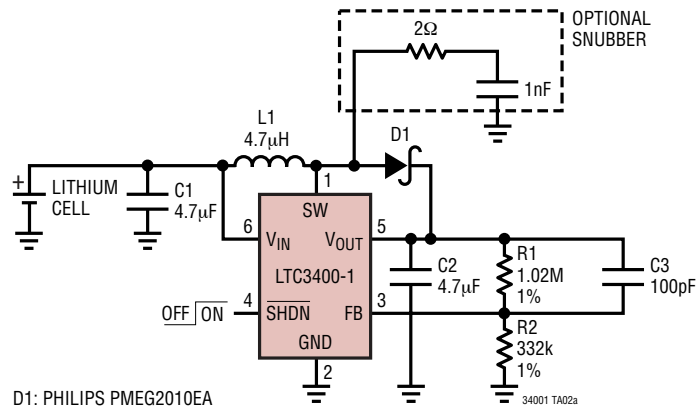

D1: PHILIPS PMEG2010EA
 L1: SUMIDA CDRH2D18/HP-4R7
 C1, C2: TAIYO YUDEN JMK212BJ475MG
 34001 TA02a

3.6V to 5V Efficiency

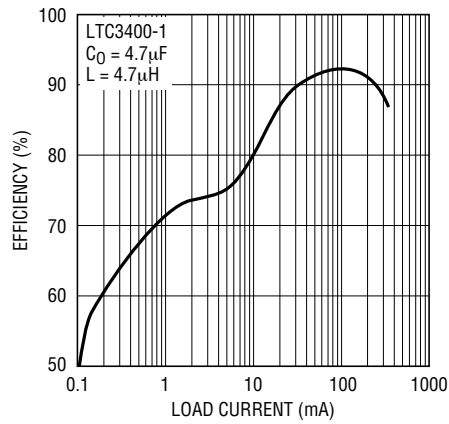

34001 TA02b

TYPICAL APPLICATIONS

Single Cell AA Cell to $\pm 3V$ Synchronous Boost Converter

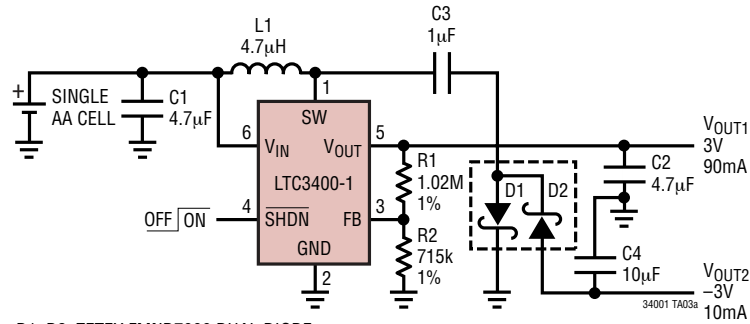

D1, D2: ZETEX FMND7000 DUAL DIODE
 L1: SUMIDA CDRH2D18/HP-4R7

PACKAGE DESCRIPTION

S6 Package
6-Lead Plastic TSOT-23
 (Reference LTC DWG # 05-08-1636)

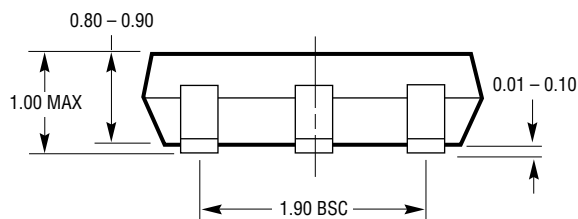
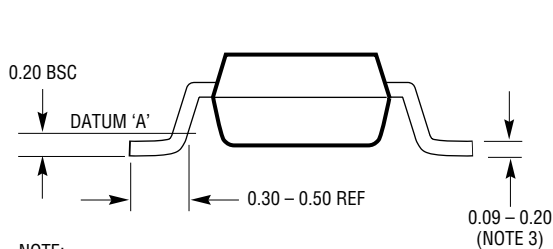
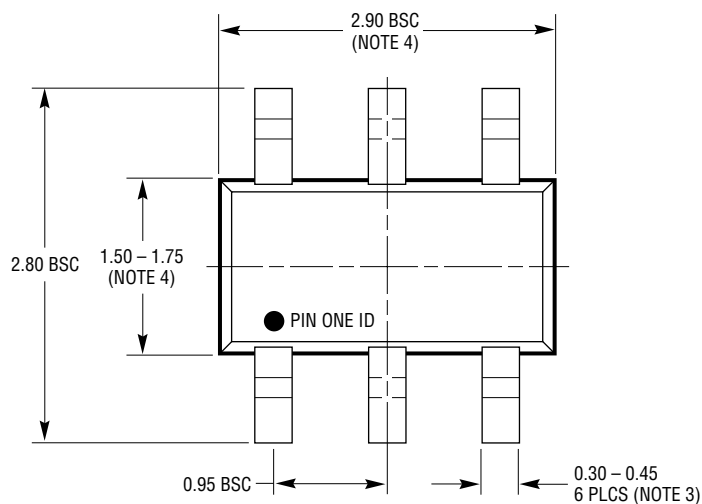
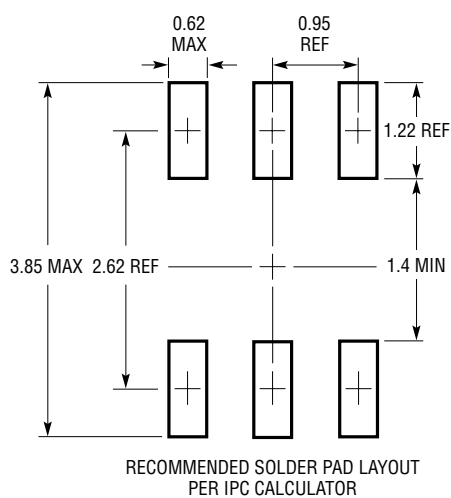

S6 TSOT-23 0302

- NOTE:
1. DIMENSIONS ARE IN MILLIMETERS
 2. DRAWING NOT TO SCALE
 3. DIMENSIONS ARE INCLUSIVE OF PLATING
 4. DIMENSIONS ARE EXCLUSIVE OF MOLD FLASH AND METAL BURR
 5. MOLD FLASH SHALL NOT EXCEED 0.254mm
 6. JEDEC PACKAGE REFERENCE IS MO-193

TYPICAL APPLICATION

Single AA Cell to 2.5V Synchronous Boost Converter

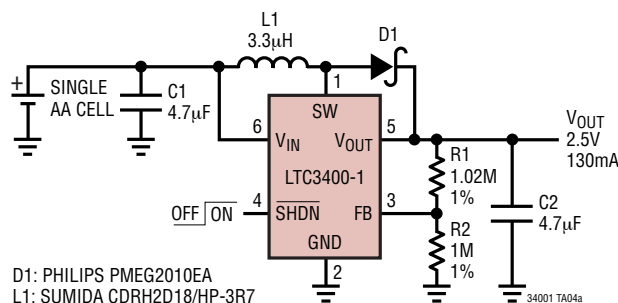

RELATED PARTS

PART NUMBER	DESCRIPTION	COMMENTS
LT1308A/LT1308B	High Current, Micropower, Single Cell 600kHz DC/DC Converter	5V at 1A with Single Li-Ion Cell, V_{OUT} to 34V
LT1613	1.4MHz, Single Cell DC/DC Converter in ThinSOT	V_{IN} as Low as 1.1V, 3V at 30mA from Single Cell
LT1615	Micropower Step-Up DC/DC Converter in ThinSOT	$I_Q = 20\mu A$, $1\mu A$ Shutdown Current, V_{IN} as Low as 1V
LT [®] 1618	1.4MHz Step-Up DC/DC Converter with Current Limit	1.5A Switch, 1.6V to 18V Input Range, Input or Output Current Limiting
LT1619	High Efficiency Boost DC/DC Controller	1A Gate Drive, 1.1V to 20V Input, Separate V_{CC} for Gate Drive
LTC1872	ThinSOT Boost DC/DC Controller	50kHz, 2.5V to 9.8V Input
LT1930/LT1930A	1.2MHz/2.2MHz DC/DC Converters in ThinSOT	$V_{IN} = 2.6V$ to 16V, 5V at 450mA from 3.3V Input
LT1932	Constant Current Step-Up LED Driver	Drives Up to Eight White LEDs, ThinSOT Package
LT1946/LT1946A	1.2MHz/2.7MHz Boost DC/DC Converters	1.5A, 36V Internal Switch, 8-Pin MSOP Package
LT1949	600kHz, 1A Switch PWM DC/DC Converter	1A, 0.5Ω , 30V Internal Switch, V_{IN} as Low as 1.5V, Low-Battery Detect Active in Shutdown
LTC3400/LTC3400B	600mA, 1.2MHz Synchronous Boost Converters in ThinSOT	Up to 92% Efficiency, 600mA Switch, No Burst Option (LTC3400B)
LTC3401	1A, 3MHz Micropower Synchronous Boost Converter	1A Switch, Programmable Frequency, 10-Pin MSOP Package
LTC3402	2A, 3MHz Micropower Synchronous Boost Converter	2A Switch, Programmable Frequency, 10-Pin MSOP Package
LTC3421	3A, 3MHz Micropower Synchronous Boost Converter	Up to 96% Efficiency, 3A Switch, True Output Disconnect, 4mm x 4mm QFN Package
LTC3423	1A, 3MHz Micropower Synchronous Boost Converter	1A Switch, Separate Bias Pin for Low Output Voltages
LTC3424	2A, 3MHz Micropower Synchronous Boost Converter	2A Switch, Separate Bias Pin for Low Output Voltages
LTC3425	5A, 8MHz, 4-Phase Micropower Synchronous Boost Converter	Up to 95% Efficiency, 5A Switch, True Output Disconnect, $I_Q = 12\mu A$, QFN Package
LTC3429	600mA, 500kHz Synchronous Boost Converter in ThinSOT	Up to 96% Efficiency, 600mA Switch, True Output Disconnect, Soft Start