

100mA Regulated Charge-Pump Inverters in ThinSOT

FEATURES

- Fixed Output Voltages: $-3V$, $-5V$ or Low Noise V_{IN} to $-V_{IN}$ Inverted Output
- $\pm 4\%$ Output Voltage Accuracy
- Low Quiescent Current: $25\mu A$
- 100mA Output Current Capability
- 2.3V to 5.5V Operating Voltage Range
- Internal 900kHz Oscillator
- “Zero Current” Shutdown
- Short-Circuit and Over-Temperature Protected
- Low Profile (1mm) ThinSOT™ Package

APPLICATIONS

- $-3V$ Generation in Single-Supply Systems
- Portable Equipment
- LCD Bias Supplies
- GaAs FET Bias Supplies

DESCRIPTION

The [LTC®1983-3](#) and [LTC1983-5](#) are inverting charge pump DC/DC converters that produce negative regulated outputs. The parts require only three tiny external capacitors and can provide up to 100mA of output current. The devices can operate in open loop mode (creating a $-V_{IN}$ supply) or regulated output mode depending on the input supply voltage and the output current.

The LTC1983-3/LTC1983-5 have many useful features for portable applications including very low quiescent current ($25\mu A$ typical) and a zero current shutdown mode programmed through the \overline{SHDN} pin.

The LTC1983-3/LTC1983-5 are over-temperature and short-circuit protected. The parts are available in a 6-pin low profile (1mm) ThinSOT package.

LT, LT, LTC, LTM, Linear Technology, Burst Mode and the Linear logo are registered trademarks and ThinSOT is a trademark of Linear Technology Corporation. All other trademarks are the property of their respective owners.

TYPICAL APPLICATION

$-3V$ at 100mA DC/DC Converter

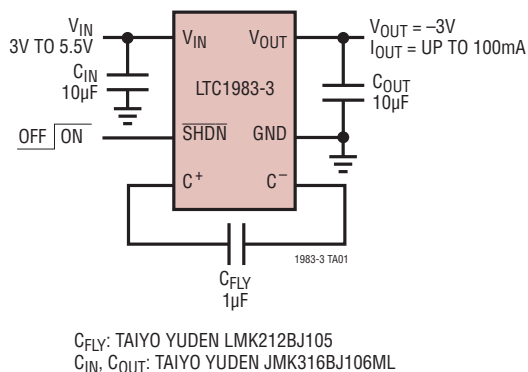

V_{OUT} vs I_{OUT}

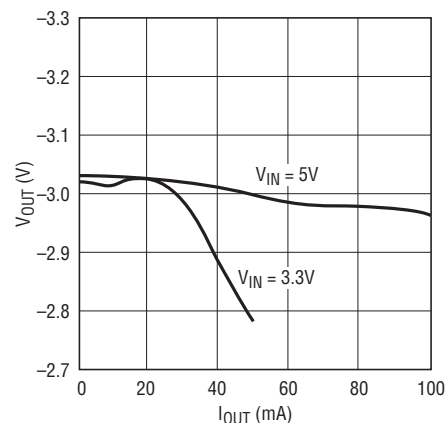

LTC1983-3

ABSOLUTE MAXIMUM RATINGS

(Note 1)

V_{IN} to GND	-0.3V to 6V
SHDN Voltage	-0.3V to 6V
V_{OUT} to GND (LTC1983-3).....	0.2V to V_{OUT} Max
V_{OUT} to GND (LTC1983-5).....	0.2V to V_{OUT} Max
I_{OUT} Max	125mA
Output Short-Circuit Duration	Indefinite
Operating Temperature Range (Note 2)....	-40°C to 85°C
Storage Temperature Range	-65°C to 125°C
Lead Temperature (Soldering, 10 sec).....	300°C

PIN CONFIGURATION

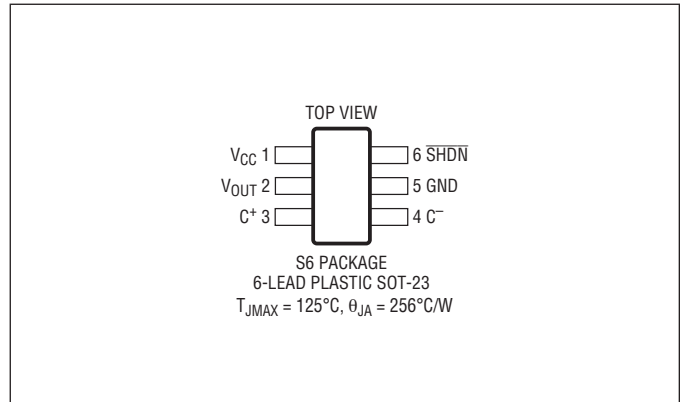

ORDER INFORMATION <http://www.linear.com/product/LTC1983-3#orderinfo>

LEAD FREE FINISH	TAPE AND REEL	PART MARKING	PACKAGE DESCRIPTION	TEMPERATURE RANGE
LTC1983ES6-3#PBF	LTC1983ES6-3#TRPBF	LTPC	6-Lead Plastic TSOT-23	-40°C to 85°C
LTC1983ES6-5#PBF	LTC1983ES6-5#TRPBF	LYTB	6-Lead Plastic TSOT-23	-40°C to 85°C

Consult LTC Marketing for parts specified with wider operating temperature ranges.

For more information on lead free part marking, go to: <http://www.linear.com/leadfree/>

For more information on tape and reel specifications, go to: <http://www.linear.com/tapeandreeel/>. Some packages are available in 500 unit reels through designated sales channels with #TRMPBF suffix.

ELECTRICAL CHARACTERISTICS

The ● denotes the specifications which apply over the full operating temperature range, otherwise specifications are at $T_A = 25^\circ\text{C}$. $V_{IN} = 5\text{V}$, $C_{FLY} = 1\mu\text{F}$, $C_{OUT} = 10\mu\text{F}$ unless otherwise noted.

PARAMETER	CONDITIONS	MIN	TYP	MAX	UNITS
V_{IN} Operating Voltage (Regulated Output Mode) (LTC1983-3) (LTC1983-5)		● 3.0		5.5	V
		5.0		5.5	V
V_{IN} Minimum Startup Voltage		2.3			V
V_{OUT} (LTC1983-3)	$V_{IN} \geq 3.3\text{V}$, $I_{OUT} \leq 25\text{mA}$ $V_{IN} \geq 5\text{V}$, $I_{OUT} \leq 100\text{mA}$	● -2.88	-3	-3.12	V
		● -2.88	-3	-3.12	V
V_{OUT} (LTC1983-5)	$V_{IN} \geq 5\text{V}$, $V_{IN} - 5\text{V} \geq I_{OUT} \cdot R_{OUT}$	● -4.8	-5	-5.2	V
V_{IN} Operating Current	$V_{IN} \leq 5.5\text{V}$, $I_{OUT} = 0\mu\text{A}$, $\text{SHDN} = V_{IN}$	●	25	60	μA
V_{IN} Operating Current (Open-Loop Mode) (LTC1983-5)	$V_{IN} = 3.3\text{V}$ $V_{IN} = 4.75\text{V}$		2.5		mA
			4		mA
V_{IN} Shutdown Current	$\text{SHDN} = 0\text{V}$, $V_{IN} \leq 5.5\text{V}$	●	0.1	1	μA
Output Ripple	$3.3 \leq V_{IN} \leq 5.5$		60		mV _{P-P}
Open-Loop Output Impedance (LTC1983-3): R_{OUT}	$V_{IN} = 3.3\text{V}$, $V_{OUT} = -3\text{V}$		11		Ω

1983fc

ELECTRICAL CHARACTERISTICS The ● denotes the specifications which apply over the full operating temperature range, otherwise specifications are at $T_A = 25^\circ\text{C}$. $V_{IN} = 5\text{V}$, $C_{FLY} = 1\mu\text{F}$, $C_{OUT} = 10\mu\text{F}$ unless otherwise noted.

PARAMETER	CONDITIONS	MIN	TYP	MAX	UNITS
Open-Loop Output Impedance (LTC1983-5): R_{OUT}	$V_{IN} = 3.3\text{V}$, $I_{OUT} \approx 50\text{mA}$		11		Ω
	$V_{IN} = 5\text{V}$, $I_{OUT} \approx 60\text{mA}$		8.5		Ω
Oscillator Frequency	(Non Burst Mode [®] Operation)		900		kHz
$\overline{\text{SHDN}}$ Input High		● 1.1			V
$\overline{\text{SHDN}}$ Input Low		●		0.3	V
$\overline{\text{SHDN}}$ Input Current	$V_{\overline{\text{SHDN}}} = 5.5\text{V}$	●	2.2	4	μA

Note 1: Stresses beyond those listed under Absolute Maximum Ratings may cause permanent damage to the device. Exposure to any Absolute Maximum Rating condition for extended periods may affect device reliability and lifetime.

Note 2: The LTC1983E-3/LTC1983E-5 are guaranteed to meet performance specifications from 0°C to 70°C . Specifications over the -40°C to 85°C operating temperature range are assured by design, characterization and correlation with statistical process controls.

TYPICAL PERFORMANCE CHARACTERISTICS

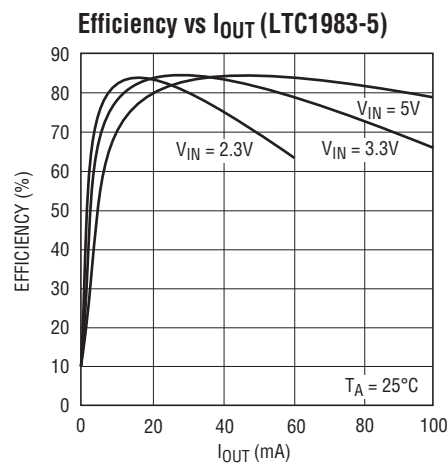

1983 G01

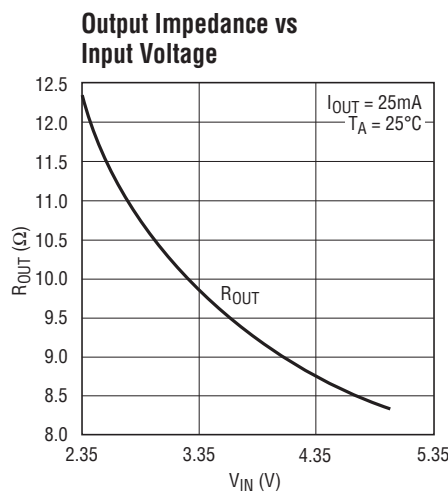

1983 TA02

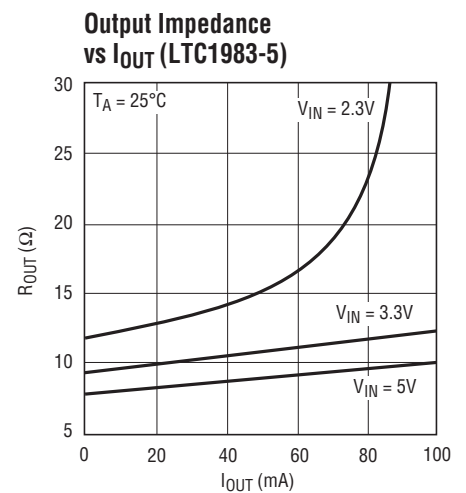

1983 G03

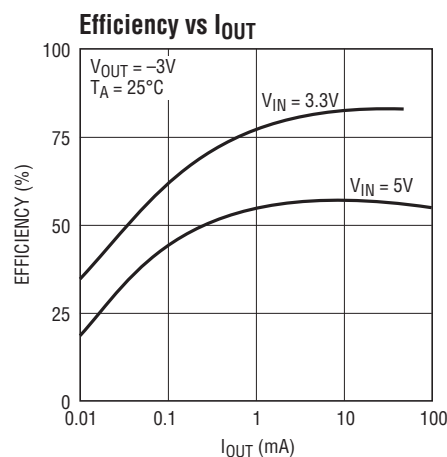

1983 G04

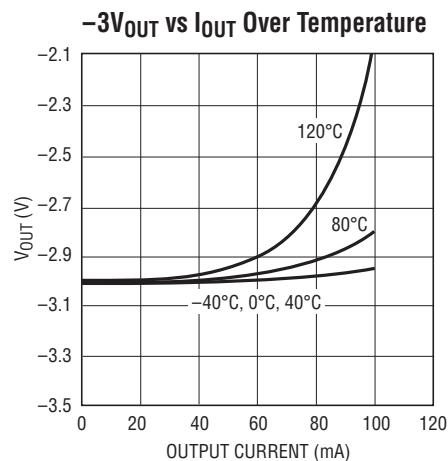

1983 G05

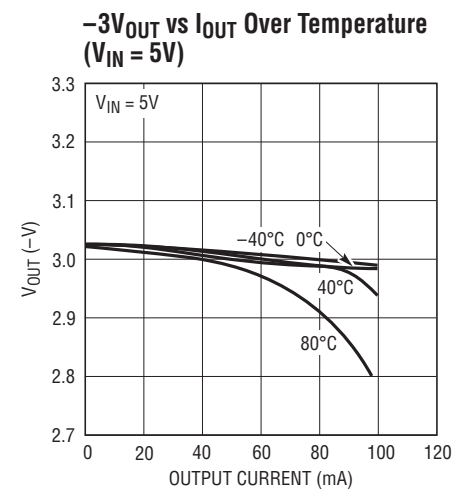

1983 G06

TYPICAL PERFORMANCE CHARACTERISTICS

Open-Loop Current vs Temperature (LTC1983-5)

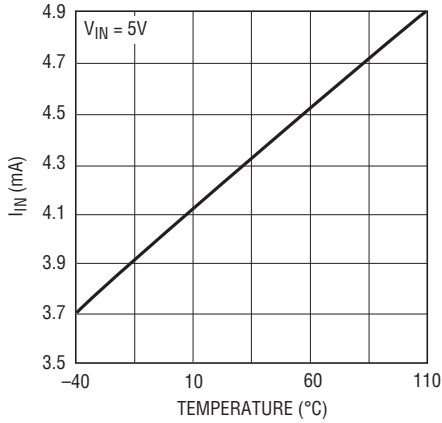

1983 G07

Open-Loop Input Current vs V_{IN} (LTC1983-5)

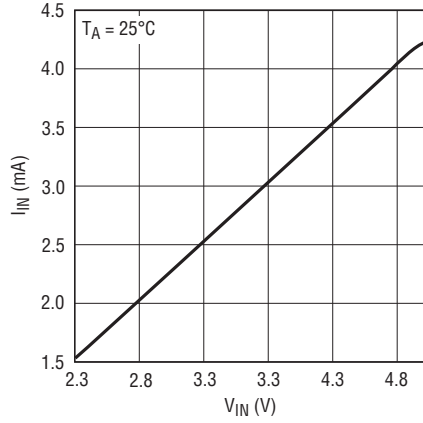

1983 G09

Burst Mode Current vs Temperature (LTC1983-3)

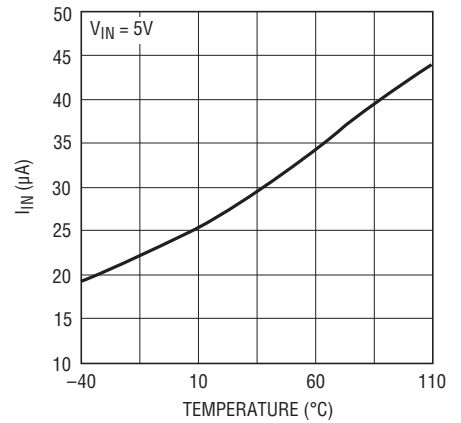

1983 G08

Burst Mode Input Current vs V_{IN} (LTC1983-3)

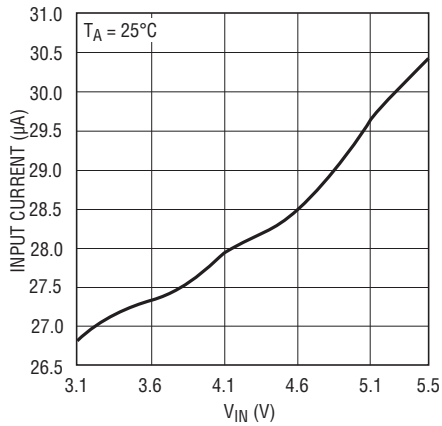

1983 G10

R_{OUT} vs Temperature (I_{OUT} = 10mA)

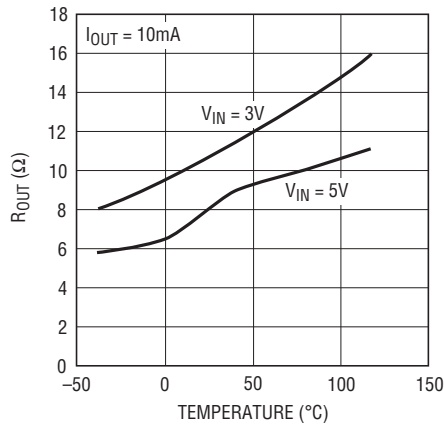

1983 G11

SHDN Pin Threshold Voltage vs Temperature

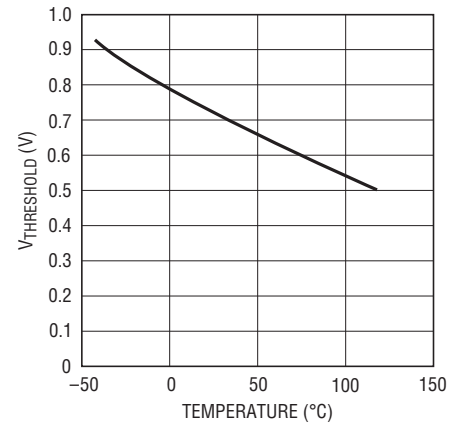

1983 G12

SHDN Pin Input Current vs Temperature

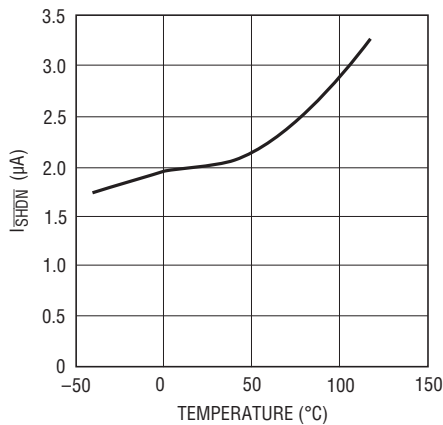

1983 G13

R_{OUT} vs C_{FLY} (V_{IN} = 5V)

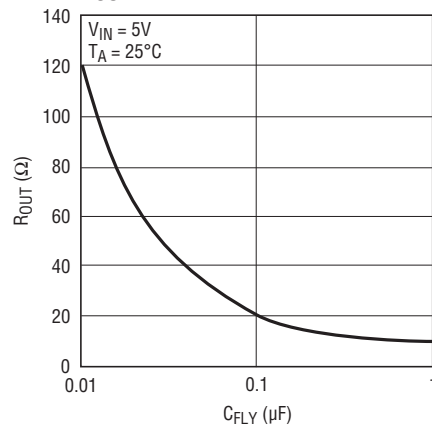

1983 G14

TYPICAL PERFORMANCE CHARACTERISTICS

V_{OUT} Start-Up into 100mA Resistive Load

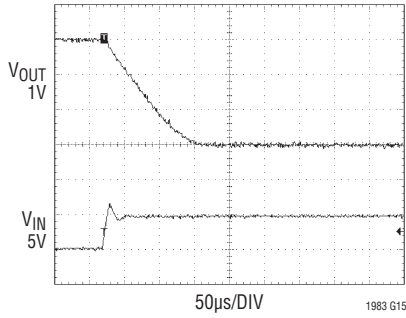

V_{OUT} Ripple at 100mA Load

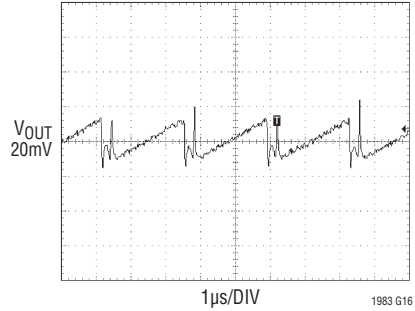

V_{OUT} Ripple at 30mA Load

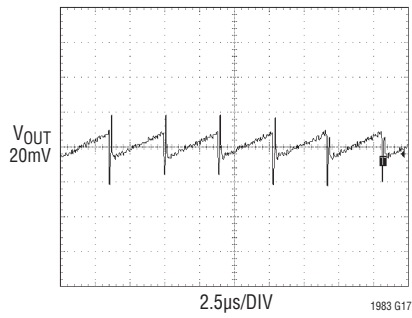

V_{OUT} Load Step Response from I_{OUT} = 0 to I_{OUT} = 100mA

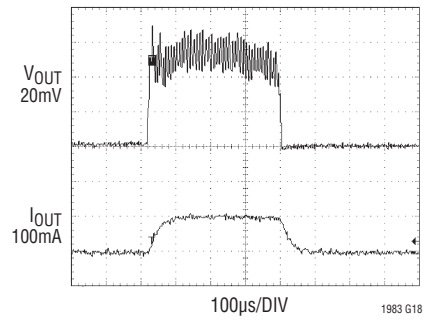

PIN FUNCTIONS

V_{IN} (Pin 1): Charge Pump Input Voltage. May be between 2.3V and 5.5V. V_{IN} should be bypassed with a $\geq 4.7\mu\text{F}$ low ESR capacitor as close as possible to the pin for best performance.

V_{OUT} (Pin 2): Regulated Output Voltage for the IC. V_{OUT} should be bypassed with a $\geq 4.7\mu\text{F}$ low ESR capacitor as close as possible to the pin for best performance.

C⁺ (Pin 3): Charge Pump Flying Capacitor Positive Terminal. This node is switched between V_{IN} and GND (It is connected to V_{CC} during shutdown).

C⁻ (Pin 4): Charge Pump Flying Capacitor Negative Terminal. This node is switched between GND and V_{OUT} (It is connected to GND during shutdown).

GND (Pin 5): Signal and Power Ground for the 6-Pin SOT-23 package. This pin should be tied to a ground plane for best performance.

SHDN (Pin 6): Shutdown. Grounding this pin shuts down the IC. Tie to V_{IN} to enable. This pin should not be pulled above the V_{IN} voltage or below GND.

BLOCK DIAGRAM

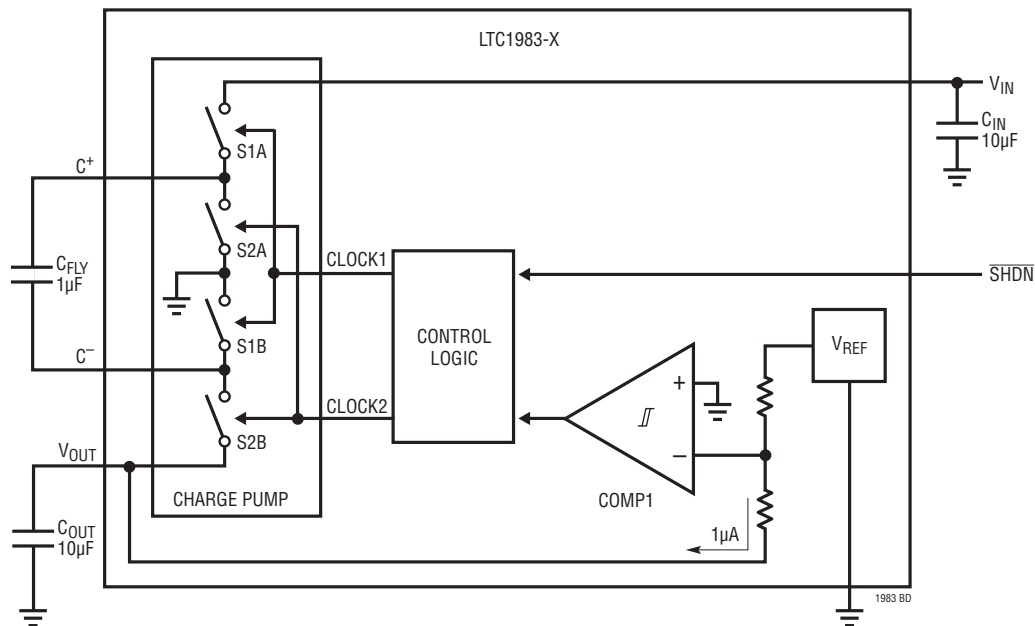

OPERATION (Refer to Block Diagram)

The LTC1983-3/LTC1983-5 use a switched capacitor charge pump to invert a positive input voltage to a regulated $-3V \pm 4\%$ (LTC1983-3) or $-5 \pm 4\%$ (LTC1983-5) output voltage. Regulation is achieved by sensing the output voltage through an internal resistor divider and enabling the charge pump when the output voltage droops above the upper trip point of COMP1. When the charge pump is enabled, a 2-phase, nonoverlapping clock controls the charge pump switches. Clock 1 closes the S1 switches which enables the flying capacitor to charge up to the V_{IN} voltage. Clock 2 closes the S2 switches that invert the V_{IN} voltage and connect the bottom plate of C_{FLY} to the output capacitor at V_{OUT} . This sequence of charging and discharging continues at a free-running frequency of 900kHz (typ) until the output voltage has been pumped down to the lower trip point of COMP1 and the charge pump is disabled. When the charge pump is disabled, the LTC1983 draws only 25 μ A (typ) from V_{IN} which provides high efficiency at low load conditions.

In shutdown mode, all circuitry is turned off and the part draws less than 1 μ A from the V_{IN} supply. V_{OUT} is also disconnected from V_{IN} and C_{FLY} . The \overline{SHDN} pin has a threshold of approximately 0.7V. The part enters shutdown when a low is applied to the \overline{SHDN} pin. The \overline{SHDN} pin should not be floated; it must be driven with a logic high or low.

Open-Loop Operation

The LTC1983-3/LTC1983-5 inverting charge pumps regulate at $-3V/-5V$ respectively, unless the input voltage is too low or the output current is too high. The equations for output voltage regulation are as follows:

$$V_{IN} - 5.06V > I_{OUT} \cdot R_{OUT} \text{ (LTC1983-5)}$$

$$V_{IN} - 3.06V > I_{OUT} \cdot R_{OUT} \text{ (LTC1983-3)}$$

If this condition is not met, then the part will run in open loop mode and act as a low output impedance inverter for which the output voltage will be:

$$V_{OUT} = -[V_{IN} - (I_{OUT} \cdot R_{OUT})]$$

For all R_{OUT} values, check the corresponding curves in the Typical Performance Characteristics section (Note: $C_{FLY} = 1\mu$ F for all R_{OUT} curves). The R_{OUT} value will be different for different flying caps, as shown in the following equation:

$$R_{OUT} = R_{OUT}(\text{curve}) - 1.11\Omega + \left(\frac{1}{f_{OSC} \cdot C_{FLY}} \right)$$

Short-Circuit/Thermal Protection

During short-circuit conditions, the LTC1983 will draw several hundred milliamps from V_{IN} causing a rise in the junction temperature. On-chip thermal shutdown circuitry disables the charge pump once the junction temperature exceeds $\approx 155^\circ\text{C}$, and re-enables the charge pump once the junction temperature falls back to $\approx 145^\circ\text{C}$. The LTC1983 will cycle in and out of thermal shutdown indefinitely without latchup or damage until the V_{OUT} short is removed.

Capacitor Selection

For best performance, it is recommended that low ESR capacitors be used for both C_{IN} and C_{OUT} to reduce noise and ripple. The C_{IN} and C_{OUT} capacitors should be either ceramic or tantalum and should be 4.7 μ F or greater. Aluminum electrolytic are not recommended because of their high equivalent series resistance (ESR). If the source impedance is very low, C_{IN} may not be needed. Increasing the size of C_{OUT} to 10 μ F or greater will reduce output voltage ripple. The flying capacitor and C_{OUT} should also have low equivalent series inductance (ESL). The board layout is critical as well for inductance for the same reason (the suggested board layout should be used).

A ceramic capacitor is recommended for the flying capacitor with a value in the range of 0.1 μ F to 4.7 μ F. Note that a large value flying cap ($>1\mu$ F) will increase output ripple unless C_{OUT} is also increased. For very low load applications, C1 may be reduced to 0.01 μ F to 0.047 μ F. This will reduce output ripple at the expense of efficiency and maximum output current.

OPERATION (Refer to Block Diagram)

There are many aspects of the capacitors that must be taken into account. First, the temperature stability of the dielectric is a main concern. For ceramic capacitors, a three character code specifies the temperature stability (e.g. X7R, Y5V, etc.). The first two characters represent the temperature range that the capacitor is specified and the third represents the absolute tolerance that the capacitor is specified to over that temperature range. **The ceramic capacitor used for the flying and output capacitors should be X5R or better.** Second, the voltage coefficient of capacitance for the capacitor must be checked and the actual value usually needs to be derated for the operating voltage (the actual value has to be larger than the value needed to take into account the loss of capacitance due to voltage bias across the capacitor). Third, the frequency characteristics need to be taken into account because capacitance goes down as the frequency of oscillation goes up. Typically, the manufacturers have capacitance vs frequency curves for their products. This curve must be referenced to be sure the capacitance will not be too small for the application. Finally, the capacitor ESR and ESL must be low for reasons mentioned in the following section.

Output Ripple

Normal LTC1983 operation produces voltage ripple on the V_{OUT} pin. Output voltage ripple is required for the LTC1983 to regulate. Low frequency ripple exists due to the hysteresis in the sense comparator and propagation delays in the charge pump enable/disable circuits. High frequency ripple is also present mainly due to ESR of the output capacitor. Typical output ripple under maximum load is 60mV_{P-P} with a low ESR $10\mu\text{F}$ output capacitor. The magnitude of the ripple voltage depends on several factors. High input voltage to negative output voltage differentials [$(V_{IN} + V_{OUT}) > 1\text{V}$] increase the output ripple since more charge is delivered to C_{OUT} per clock cycle. A large flying capacitor ($>1\mu\text{F}$) also increases ripple for the same reason. Large output current load and/or a small output capacitor ($<10\mu\text{F}$)

results in higher ripple due to higher output voltage dV/dt . High ESR capacitors ($\text{ESR} > 0.1\Omega$) on the output pin cause high frequency voltage spikes on V_{OUT} with every clock cycle.

There are several ways to reduce the output voltage ripple. A larger C_{OUT} capacitor ($22\mu\text{F}$ or greater) will reduce both the low and high frequency ripple due to the lower C_{OUT} charging and discharging dV/dt and the lower ESR typically found with higher value (larger case size) capacitors. A low ESR ceramic output capacitor will minimize the high frequency ripple, but will not reduce the low frequency ripple unless a high capacitance value is chosen. A reasonable compromise is to use a $10\mu\text{F}$ to $22\mu\text{F}$ tantalum capacitor in parallel with a $1\mu\text{F}$ to $4.7\mu\text{F}$ ceramic capacitor on V_{OUT} to reduce both the low and high frequency ripple. However, the best solution is to use $10\mu\text{F}$ to $22\mu\text{F}$, X5R ceramic capacitors which are available in 1206 package sizes. An RC filter may also be used to reduce high frequency voltage spikes (see Figure 1).

In low load or high V_{IN} applications, smaller values for C_{FLY} may be used to reduce output ripple. A smaller flying capacitor ($0.01\mu\text{F}$ to $0.047\mu\text{F}$) delivers less charge per clock cycle to the output capacitor resulting in lower output ripple. However, the smaller value flying caps also reduce the maximum I_{OUT} capability as well as efficiency.

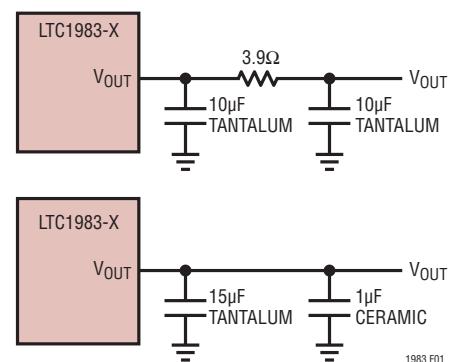

Figure 1. Output Ripple Reduction Techniques

OPERATION (Refer to Block Diagram)

Inrush Currents

During normal operation, V_{IN} will experience current transients in the several hundred milliamp range whenever the charge pump is enabled. During start-up, these inrush currents may approach 1 to 2 amps. For this reason, it is important to minimize the source resistance between the input supply and the V_{IN} pin. Too much source resistance may result in regulation problems or even prevent start-up. One way that this can be avoided (especially when the source impedance can't be lowered due to system constraints) is to use a large V_{IN} capacitor with low ESR right at the V_{IN} pin. If ceramic capacitors are used, you may need to add 1 μ F to 10 μ F tantalum capacitor in parallel to limit input voltage transients. Input voltage transients will occur if V_{IN} is applied via a switch or a plug. One example of this situation is in USB applications.

Ultralow Quiescent Current Regulated Supply

The LTC1983 contains an internal resistor divider (refer to the Block Diagram) that draws only 1 μ A (typ for the 3V version) from V_{OUT} during normal operation. During shutdown, the resistor divider is disconnected from the output and the part draws only leakage current from the output. During no-load conditions, applying a 1Hz to 100Hz, 2% to 5% duty cycle signal to the \overline{SHDN} pin ensures that the circuit of Figure 2 comes out of shutdown frequently enough to maintain regulation even under low-load conditions. Since the part spends nearly all of its time in shutdown, the no-load quiescent current is essentially zero. However, the part will still be in operation during the time the \overline{SHDN} pin is high, so the current will not be zero and can be calculated using the following equations to determine the approximate maximum current: $I_{IN(MAX)} = [(Time\ out\ of\ shutdown) \cdot (Burst\ Mode\ operation\ quiescent\ current) + (Normal\ operating\ I_{IN}) \cdot (Time\ output\ is\ being\ charged\ before\ the\ LTC1983\ enters\ Burst\ Mode\ operation)] / (Period\ of\ \overline{SHDN}\ signal)$. This number will be highly dependent on the amount of board leakage current and how many devices are connected to V_{OUT} (each will draw some leakage current) and must be calculated and verified for each different board design.

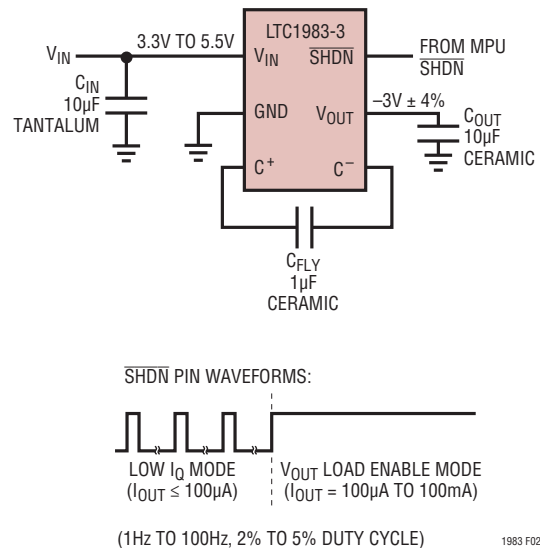

Figure 2. Ultralow Quiescent Current Regulated Supply

The LTC1983 must be out of shutdown for a minimum duration of 200 μ s to allow enough time to sense the output and keep it in regulation. A 1Hz, 2% duty cycle signal will keep V_{OUT} in regulation under no-load conditions. Even though the term no-load is used, there will always be board leakage current and leakage current drawn by anything connected to V_{OUT} . This is why it is necessary to wake the part up every once in a while to verify regulation. As the V_{OUT} load current increases, the frequency with which the part is taken out of shutdown must also be increased to prevent V_{OUT} from drooping below the -2.88V (for the 3V version) during the OFF phase (see Figure 3). A 100Hz, 2% duty cycle signal on the \overline{SHDN} pin ensures proper regulation with load currents as high as 100 μ A. When load current greater than 100 μ A is needed, the \overline{SHDN} pin must be forced high as in normal operation.

Each time the LTC1983 comes out of shutdown, the part delivers a minimum of one clock cycle worth of charge to the output. Under high V_{IN} (>4V) and/or low I_{OUT} (<10 μ A) conditions, this behavior may cause a net excess of charge to be delivered to the output capacitor if a high frequency signal is used on the \overline{SHDN} pin (e.g., 50Hz to 100Hz). Under such conditions, V_{OUT} will slowly drift positive and may even go out of regulation. To avoid this potential problem

OPERATION (Refer to Block Diagram)

in the low I_Q mode, it is necessary to switch the part in and out of shutdown at the minimum allowable frequency (refer to Figure 3) for a given output load.

General Layout Considerations

Due to the high switching frequency and high transient currents produced by the LTC1983, careful board layout is a must. A clean board layout using a ground plane and short connections to all capacitors will improve performance and ensure proper regulation under all conditions (refer to Figures 4a and 4b). You will not get advertised performance with careless layout.

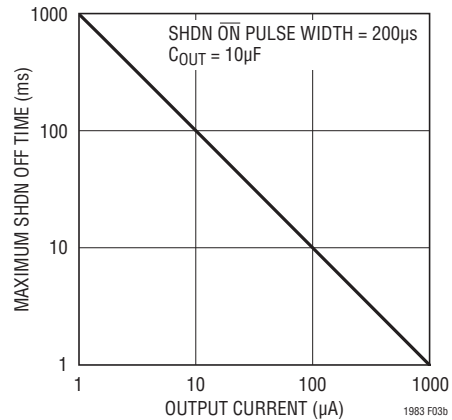

Figure 3

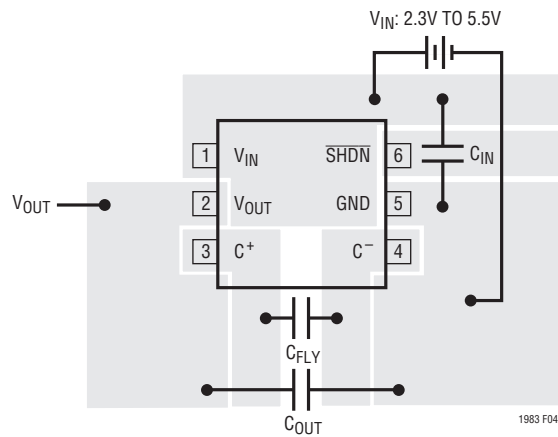

Figure 4a. Recommended Component Placement for a Single Layer Board

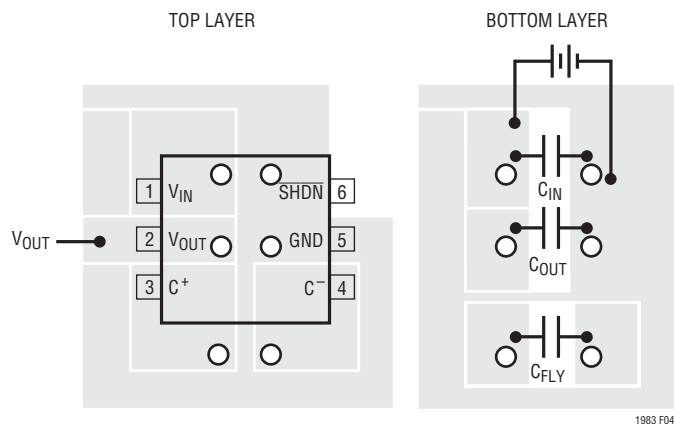
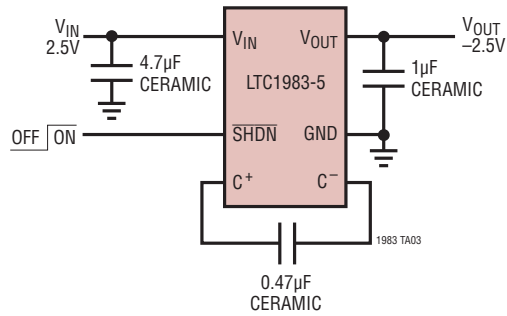

Figure 4b. Recommended Component Placement for a Double Layer Board

TYPICAL APPLICATIONS

2.5V to -2.5V DC/DC Converter



100mA Inverting DC/DC Converter

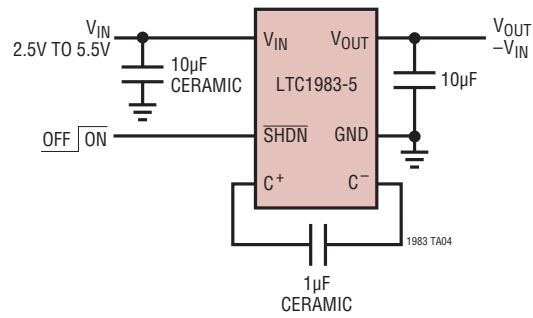

PACKAGE DESCRIPTION

Please refer to <http://www.linear.com/product/LTC1983#packaging> for the most recent package drawings.

S6 Package 6-Lead Plastic TSOT-23 (Reference LTC DWG # 05-08-1636)

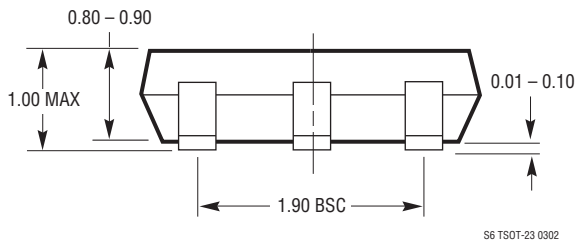
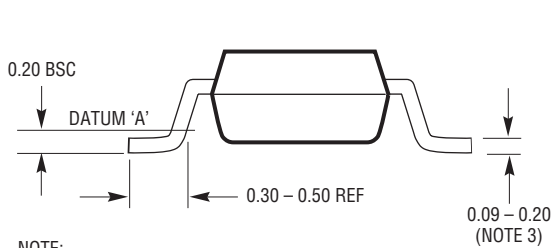
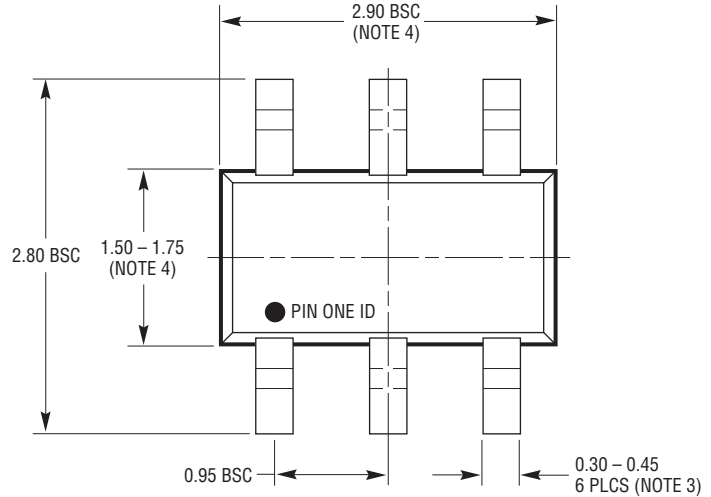
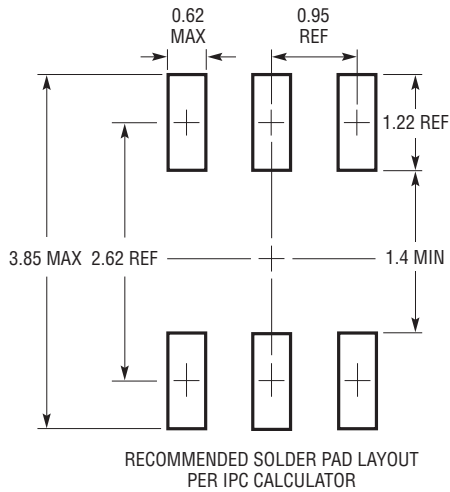

- NOTE:
1. DIMENSIONS ARE IN MILLIMETERS
 2. DRAWING NOT TO SCALE
 3. DIMENSIONS ARE INCLUSIVE OF PLATING
 4. DIMENSIONS ARE EXCLUSIVE OF MOLD FLASH AND METAL BURR
 5. MOLD FLASH SHALL NOT EXCEED 0.254mm
 6. JEDEC PACKAGE REFERENCE IS MO-193

S6 TSOT-23 0302

REVISION HISTORY (Revision history begins at Rev B)

REV	DATE	DESCRIPTION	PAGE NUMBER
B	06/16	Revised R_{OUT} vs C_{FLY} ($V_{IN} = 5V$) graph.	4
C	09/16	Corrected Order Information table.	2

TYPICAL APPLICATION

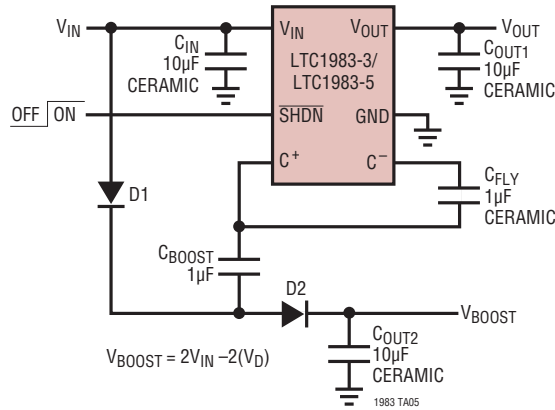
Combined Unregulated Doubler
and Regulated Inverter

RELATED PARTS

PART NUMBER	DESCRIPTION	COMMENTS
LTC1261	Switched-Capacitor Regulated Voltage Inverter	Selectable Fixed Output Voltages
LTC1261L	Switched-Capacitor Regulated Voltage Inverter	Adjustable and Fixed Output Voltages, Up to 20mA I_{OUT} , MSOP
LTC1429	Clock-Synchronized Switched-Capacitor Voltage Inverter	Synchronizable Up to 2MHz System Clock
LTC1514/LTC1515	Step-Up/Step-Down Switched-Capacitor DC/DC Converters	V_{IN} 2V to 10V, Adjustable or Fixed V_{OUT} , I_{OUT} to 50mA
LTC1516	Micropower Regulated 5V Charge Pump DC/DC Converter	$I_{OUT} = 20\text{mA}$ ($V_{IN} \geq 2\text{V}$), $I_{OUT} = 50\text{mA}$ ($V_{IN} \geq 3\text{V}$)
LTC1522	Micropower Regulated 5V Charge Pump DC/DC Converter	$I_{OUT} = 10\text{mA}$ ($V_{IN} \geq 2.7\text{V}$), $I_{OUT} = 20\text{mA}$ ($V_{IN} \geq 3\text{V}$)
LTC1550L/LTC1551L	Low Noise, Switched-Capacitor Regulated Voltage Inverters	900kHz Charge Pump, 1mV _{P-P} Ripple
LT1611	1.4MHz Inverting Mode Switching Regulator	-5V at 150mA from a 5V Input, 5-Lead ThinSOT
LT1617/LT1617-1	Micropower, Switched-Capacitor Voltage Inverter	V_{IN} 1.2V/1V to 15V; 350mA/100mA Current Limit
LTC1682/-3.3/-5	Doubler Charge Pumps with Low Noise LDO	MS8 and SO-8 Packages, $I_{OUT} = 80\text{mA}$, Output Noise = 60µV _{RMS}
LTC1751/-3.3/-5	Doubler Charge Pumps	$V_{OUT} = 5\text{V}$ at 100mA; $V_{OUT} = 3.3\text{V}$ at 80mA; ADJ; MSOP Packages
LTC1754/-3.3/-5	Doubler Charge Pumps with Shutdown	ThinSOT Package; $I_Q = 13\mu\text{A}$; $I_{OUT} = 50\text{mA}$
LTC1928-5	Doubler Charge Pump with Low Noise LDO	ThinSOT Output Noise = 60µV _{RMS} ; $V_{OUT} = 5\text{V}$; $V_{IN} = 2.7\text{V}$ to 4V
LTC3200	Constant Frequency Doubler Charge Pump	Low Noise, 5V Output or Adjustable