

# Isolated No-Opto Synchronous Flyback Controller with Wide Input Supply Range

## FEATURES

- Senses Output Voltage Directly from Primary Side Winding—No Opto-Isolator Required
- Synchronous Driver for High Efficiency
- Input Voltage Limited Only by External Power Components
- Accurate Output Regulation without User Trims
- Switching Frequency from 50kHz to 250kHz
- Synchronizable
- Load Compensation
- Programmable Undervoltage Lockout
- Available in a Thermally Enhanced 16-Lead TSSOP Package

## APPLICATIONS

- Isolated Medium Power (10W to 60W) Supplies
- Isolated Telecom, Medical Converters
- Instrumentation Power Supplies
- Isolated Power over Ethernet Supplies

## DESCRIPTION

The LT<sup>®</sup>3825 is an isolated switching regulator controller designed for medium power flyback topologies. A typical application is 10W to 60W with input voltage limited only by external power path components. A third transformer winding provides output voltage feedback.

The LT3825 is a current mode controller that regulates output voltage based on sensing secondary voltage via a transformer winding during flyback. This allows for tight output regulation without the use of an opto-isolator, improving dynamic response and reliability. Synchronous rectification increases converter efficiency and improves output cross regulation in multiple output converters.

The LT3825 operates in forced continuous conduction mode which improves cross regulation in multiple winding applications. Switching frequency is user programmable and can be externally synchronized. The part also has load compensation, undervoltage lockout and soft-start circuitry.

LT, LT, LTC, LTM, Burst Mode, SwitcherCAD, Linear Technology and the Linear logo are registered trademarks and No R<sub>SENSE</sub>, ThinSOT are trademarks of Linear Technology Corporation. All other trademarks are the property of their respective owners. Protected by U.S. Patents, including 6948466, 5841643.

## TYPICAL APPLICATION

48V to 3.3V at 12A Isolated Supply

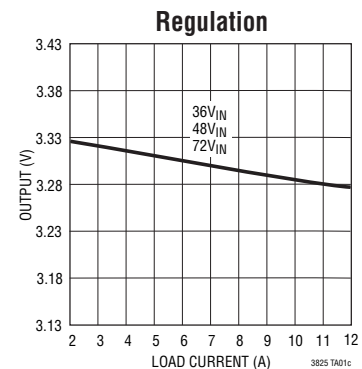
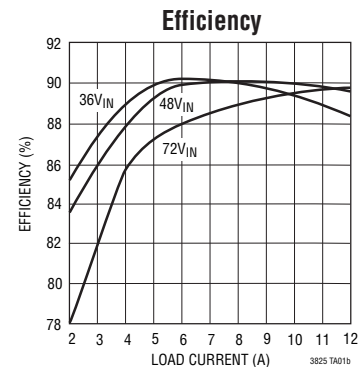
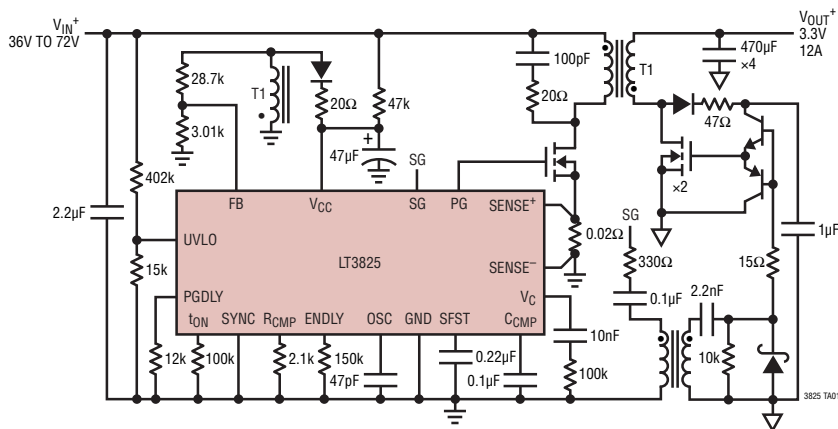

## ABSOLUTE MAXIMUM RATINGS

(Note 1)

$V_{CC}$ to GND	
Low Impedance Source .....	-0.3V to 18V
Current Fed	
( $V_{CC}$ Has Internal 19.5V Clamp) .....	30mA Into $V_{CC}$
UVLO, SYNC Pin Voltage .....	-0.3V to $V_{CC}$
SENSE <sup>-</sup> , SENSE <sup>+</sup> Pin Voltage .....	-0.5V, +0.5V
FB Pin Current .....	±2mA
$V_C$ Pin Current .....	±1mA
Operating Junction Temperature Range	
(Notes 2, 3, 4) .....	-40°C to 125°C
Storage Temperature Range .....	-65°C to 150°C
Lead Temperature (Soldering, 10 sec) .....	300°C

## PIN CONFIGURATION

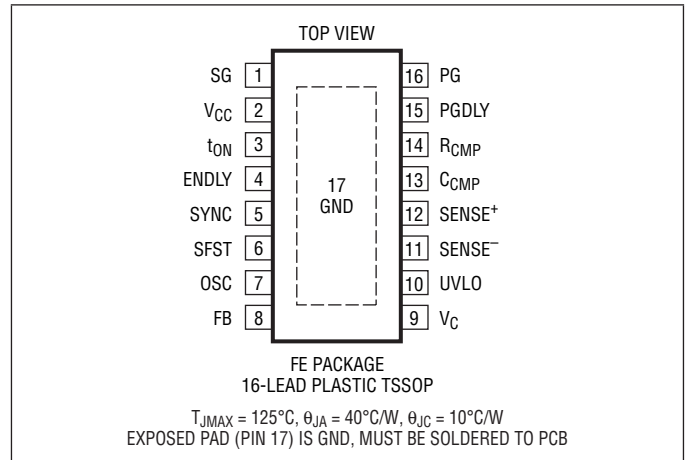

## ORDER INFORMATION

LEAD FREE FINISH	TAPE AND REEL	PART MARKING	PACKAGE DESCRIPTION	TEMPERATURE RANGE
LT3825EFE#PBF	LT3825EFE#TRPBF	3825EFE	16-Lead Plastic 4.4mm TSSOP	-40°C to 125°C
LEAD BASED FINISH	TAPE AND REEL	PART MARKING	PACKAGE DESCRIPTION	TEMPERATURE RANGE
LT3825EFE	LT3825EFE#TR	3825EFE	16-Lead Plastic 4.4mm TSSOP	-40°C to 125°C

Consult LTC Marketing for parts specified with wider operating temperature ranges.

For more information on lead free part marking, go to: <http://www.linear.com/leadfree/>

For more information on tape and reel specifications, go to: <http://www.linear.com/tapeandree/>

## ELECTRICAL CHARACTERISTICS

The ● denotes the specifications which apply over the full operating junction temperature range, otherwise specifications are at  $T_A = 25^\circ\text{C}$ .  $V_{CC} = 14\text{V}$ ; PG, SG Open;  $V_C = 1.5\text{V}$ ,  $V_{\text{SENSE}^-} = 0\text{V}$ ;  $R_{\text{CMP}} = 1\text{k}$ ,  $R_{\text{TON}} = 90\text{k}$ ,  $R_{\text{PGDLY}} = 27.4\text{k}$ ,  $R_{\text{ENDLY}} = 90\text{k}$ , unless otherwise specified (Note 3).

PARAMETER	CONDITIONS	MIN	TYP	MAX	UNITS
<b>Power Supply</b>					
$V_{CC}$ Turn-On Voltage		● 14.0	15.3	16.0	V
$V_{CC}$ Turn-Off Voltage		● 8	9.7	11	V
$V_{CC}$ Hysteresis	$V_{\text{CC(ON)}} - V_{\text{CC(OFF)}}$	● 4.0	5.6	6.5	V
$V_{CC}$ Shunt Clamp	$V_{\text{UVLO}} = 0\text{V}$ , $I_{V_{CC}} = 15\text{mA}$	● 19.5	20.5		V
$V_{CC}$ Supply Current (Note 5) ( $I_{CC}$ )	$V_C = \text{Open}$	● 4	6.4	10	mA
$V_{CC}$ Start-Up Current	$V_{CC} = 10\text{V}$	●	180	400	μA
<b>Feedback Amplifier</b>					
Feedback Regulation Voltage ( $V_{\text{FB}}$ )		● 1.220	1.237	1.251	V
Feedback Pin Input Bias Current	$R_{\text{CMP}}$ Open		200		nA
Feedback Amplifier Transconductance	$\Delta I_C = \pm 10\mu\text{A}$	● 700	1000	1400	μmho
Feedback Amplifier Source or Sink Current		● 25	55	90	μA
Feedback Amplifier Clamp Voltage	$V_{\text{FB}} = 0.9\text{V}$ $V_{\text{FB}} = 1.4\text{V}$		2.56		V

3525fe

**ELECTRICAL CHARACTERISTICS** The ● denotes the specifications which apply over the full operating junction temperature range, otherwise specifications are at  $T_A = 25^\circ\text{C}$ .  $V_{CC} = 14\text{V}$ ; PG, SG Open;  $V_C = 1.5\text{V}$ ,  $V_{\text{SENSE}^-} = 0\text{V}$ ;  $R_{\text{CMP}} = 1\text{k}$ ,  $R_{\text{TON}} = 90\text{k}$ ,  $R_{\text{PGDLY}} = 27.4\text{k}$ ,  $R_{\text{ENDLY}} = 90\text{k}$ , unless otherwise specified (Note 3).

PARAMETER	CONDITIONS		MIN	TYP	MAX	UNITS
Reference Voltage Line Regulation	$12\text{V} \leq V_{CC} \leq 18\text{V}$	●		0.005	0.02	%/V
Feedback Amplifier Voltage Gain	$V_C = 1.2\text{V}$ to $1.7\text{V}$			1400		V/V
Soft-Start Charging Current	$V_{\text{SFST}} = 1.5\text{V}$		16	20	25	$\mu\text{A}$
Soft-Start Discharge Current	$V_{\text{SFST}} = 1.5\text{V}$ , $V_{\text{UVLO}} = 0\text{V}$		0.8	1.3		mA
Control Pin Threshold ( $V_C$ )	Duty Cycle = Min			1.0		V
<b>Gate Outputs</b>						
PG, SG Output High Level		●	6.6	7.4	8.0	V
PG, SG Output Low Level		●		0.01	0.05	V
PG, SG Output Shutdown Strength	$V_{\text{UVLO}} = 0\text{V}$ ; $I_{\text{PG}}$ , $I_{\text{SG}} = 20\text{mA}$	●		1.6	2.3	V
PG Rise Time	$C_{\text{PG}} = 1\text{nF}$			11		ns
SG Rise Time	$C_{\text{SG}} = 1\text{nF}$			15		ns
PG, SG Fall Time	$C_{\text{PG}}$ , $C_{\text{SG}} = 1\text{nF}$			10		ns
<b>Current Amplifier</b>						
Switch Current Limit at Maximum $V_C$	$V_{\text{SENSE}^+}$	●	88	98	110	mV
$\Delta V_{\text{SENSE}}/\Delta V_C$				0.07		V/V
Sense Voltage Overcurrent Fault Voltage	$V_{\text{SENSE}^+}$	●		206	230	mV
<b>Timing</b>						
Switching Frequency ( $f_{\text{OSC}}$ )	$C_{\text{OSC}} = 100\text{pF}$	●	84	100	110	kHz
Oscillator Capacitor Value ( $C_{\text{OSC}}$ )	(Note 6)		33		200	pF
Minimum Switch On-Time ( $t_{\text{ON(MIN)}}$ )				200		ns
Flyback Enable Delay Time ( $t_{\text{ED}}$ )				265		ns
PG Turn-On Delay Time ( $t_{\text{PGDLY}}$ )				200		ns
Maximum Switch Duty Cycle		●	85	88		%
SYNC Pin Threshold		●		1.53	2.1	V
SYNC Pin Input Resistance				40		k $\Omega$
<b>Load Compensation</b>						
Load Comp to $V_{\text{SENSE}}$ Offset Voltage	$V_{\text{RCMP}}$ with $V_{\text{SENSE}^+} = 0\text{V}$			1		mV
Feedback Pin Load Compensation Current	$V_{\text{SENSE}^+} = 20\text{mV}$ , $V_{\text{FB}} = 1.230\text{V}$			20		$\mu\text{A}$
<b>UVLO Function</b>						
UVLO Pin Threshold ( $V_{\text{UVLO}}$ )		●	1.215	1.240	1.265	V
UVLO Pin Bias Current	$V_{\text{UVLO}} = 1.2\text{V}$ $V_{\text{UVLO}} = 1.3\text{V}$		-0.25 -4.50	0 -3.4	$\pm 0.25$ -2.50	$\mu\text{A}$ $\mu\text{A}$

**Note 1:** Stresses beyond those listed under Absolute Maximum Ratings may cause permanent damage to the device. Exposure to any Absolute Maximum Rating condition for extended periods may affect device reliability and lifetime.

**Note 2:** This IC includes overtemperature protection that is intended to protect the device during momentary overload conditions. Junction temperature will exceed  $125^\circ\text{C}$  when overtemperature protection is active. Continuous operation above the specified maximum operating junction temperature may impair device reliability.

**Note 3:** The LT3825 is tested under pulsed load conditions, such that  $T_J \approx T_A$ . The LT3825E is guaranteed to meet performance specifications from  $0^\circ\text{C}$  to  $125^\circ\text{C}$ . Specifications over the  $-40^\circ\text{C}$  to  $125^\circ\text{C}$  operating junction temperature

range are assured by design, characterization and correlation with statistical process controls. Note that the maximum ambient temperature consistent with these specifications is determined by specific operating conditions in conjunction with board layout, the rated package thermal resistance and other environmental factors.

**Note 4:**  $T_J$  is calculated from the ambient temperature  $T_A$  and power dissipation  $P_D$  according to the following formula:

$$T_J = T_A + (P_D \cdot 40^\circ\text{C/W})$$

**Note 5:** Supply current does not include gate charge current to the MOSFETs. See Applications Information.

**Note 6:** Component value range guaranteed by design.

## TYPICAL PERFORMANCE CHARACTERISTICS

**$V_{CC(ON)}$  and  $V_{CC(OFF)}$  vs Temperature**

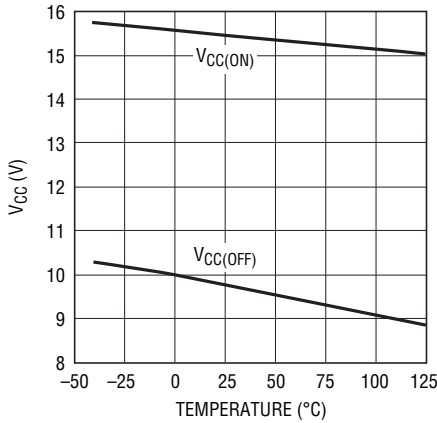

3825 G01

**$V_{CC}$  Start-Up Current vs Temperature**

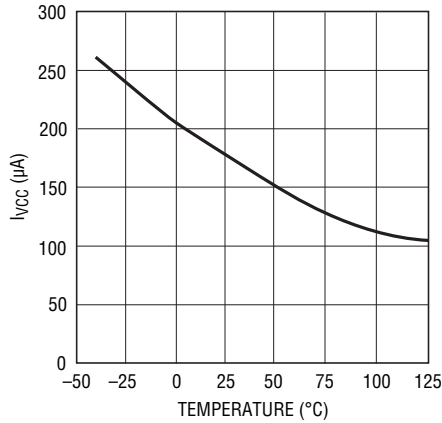

3825 G02

**$V_{CC}$  Current vs Temperature**

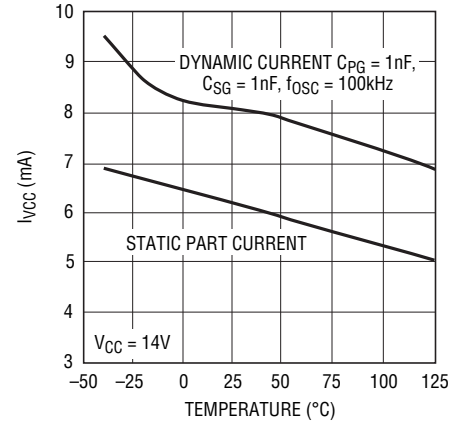

3825 G03

**SENSE Voltage vs Temperature**

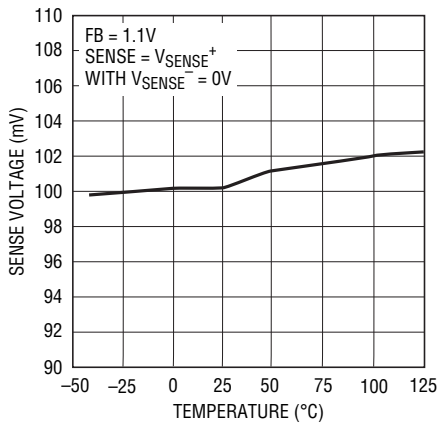

3825 G04

**SENSE Fault Voltage vs Temperature**

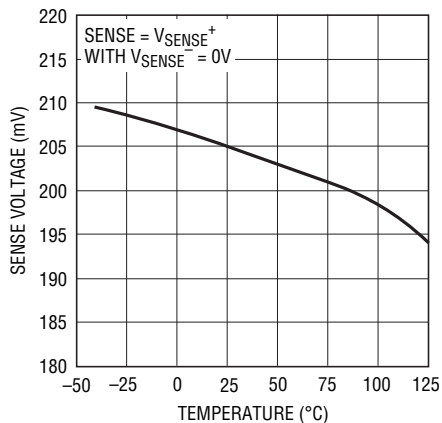

3825 G05

**Oscillator Frequency vs Temperature**

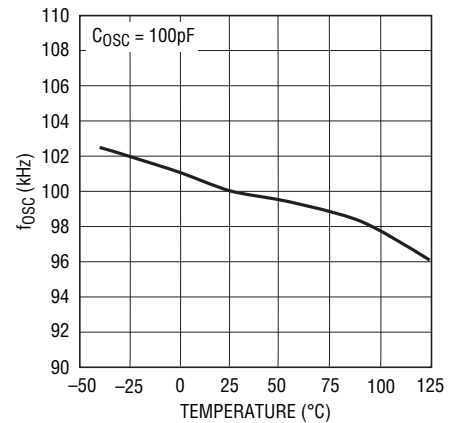

3825 G06

**$V_{FB}$  vs Temperature**

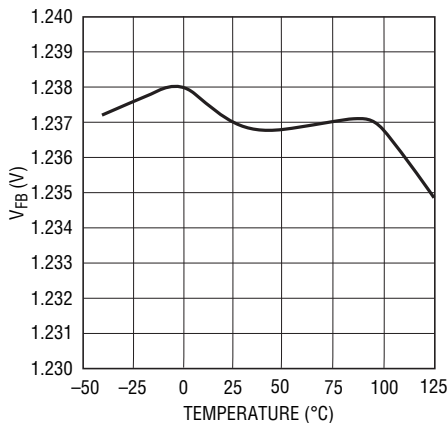

3825 G07

**Feedback Pin Input Bias vs Temperature**

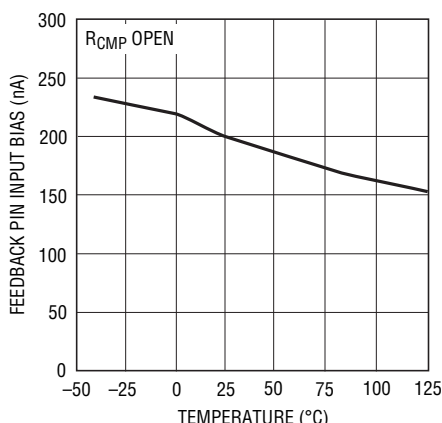

3825 G08

**$V_{FB}$  Reset vs Temperature**

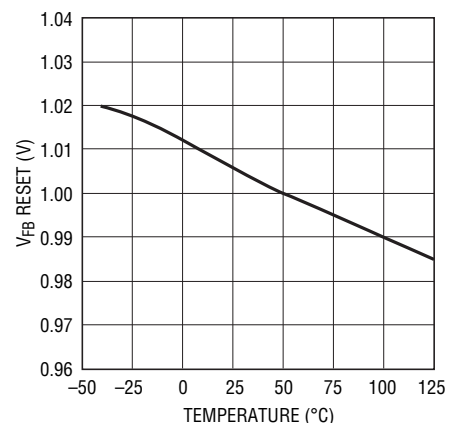

3825 G09

# TYPICAL PERFORMANCE CHARACTERISTICS

**Feedback Amplifier Output Current vs  $V_{FB}$**

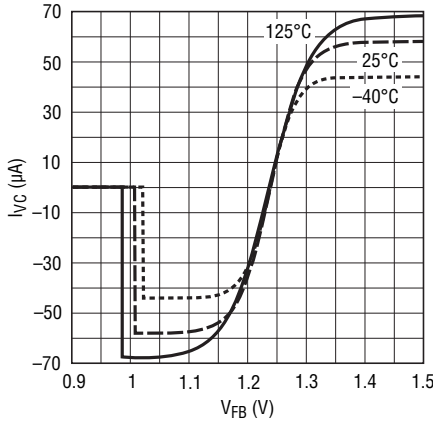

3825 G10

**Feedback Amplifier Source and Sink Current vs Temperature**

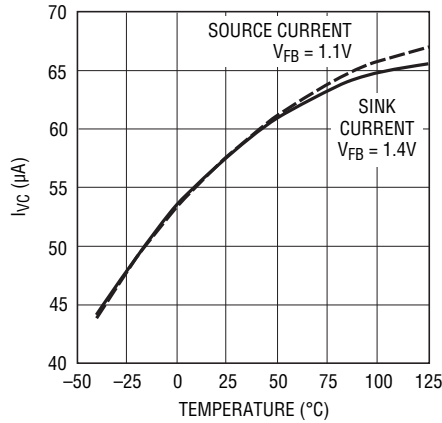

3825 G11

**Feedback Amplifier  $g_m$  vs Temperature**

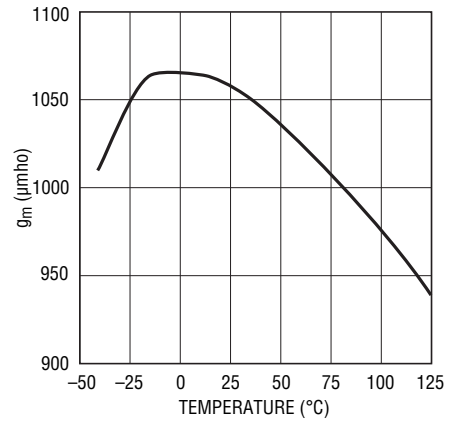

3825 G12

**Feedback Amplifier Voltage Gain vs Temperature**

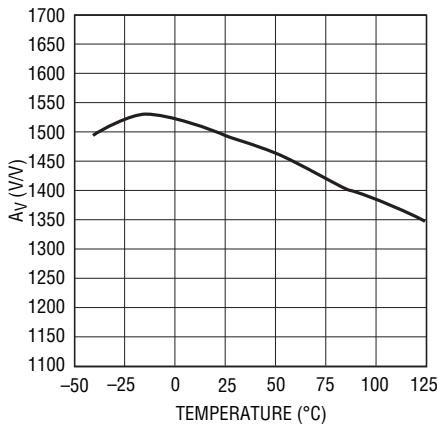

3825 G13

**UVLO vs Temperature**

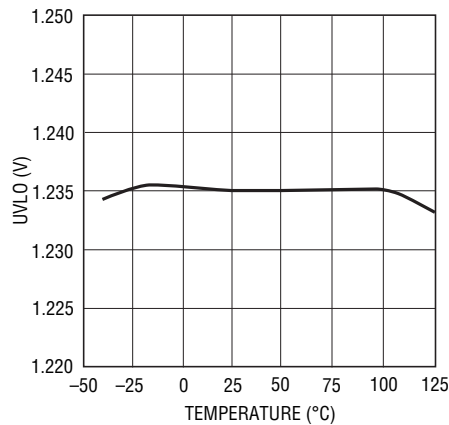

3825 G14

**$I_{UVLO}$  Hysteresis vs Temperature**

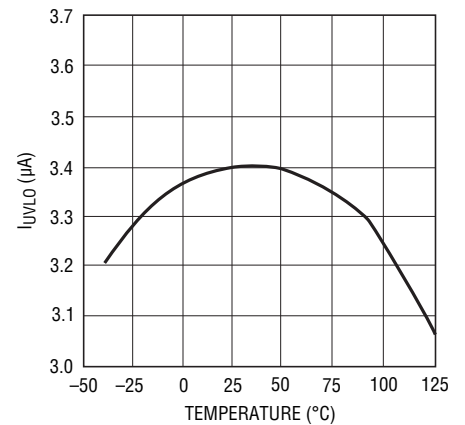

3825 G15

**Soft-Start Charge Current vs Temperature**

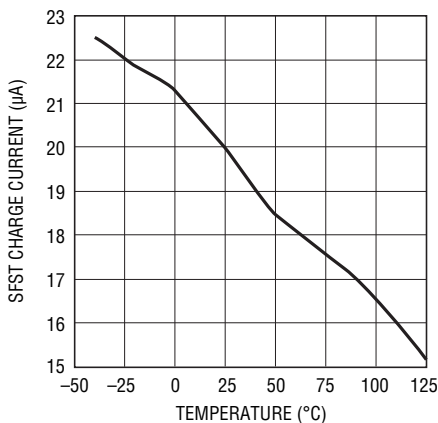

3825 G16

**PG, SG Rise and Fall Times vs Load Capacitance**

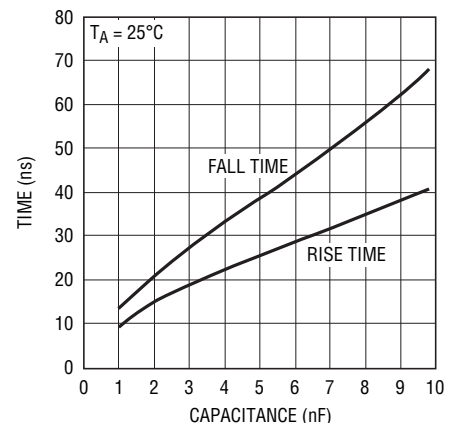

3825 G17

**$V_{CC}$  Clamp Voltage vs Temperature**

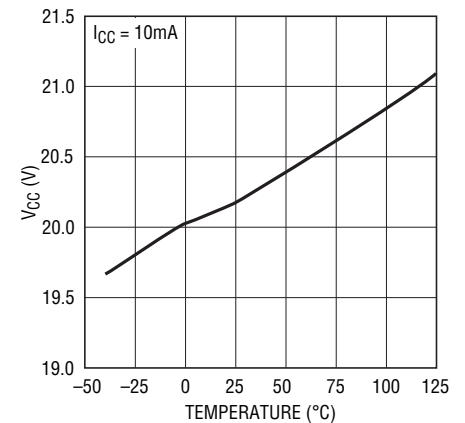

3825 G18

## TYPICAL PERFORMANCE CHARACTERISTICS

Minimum PG On-Time vs Temperature

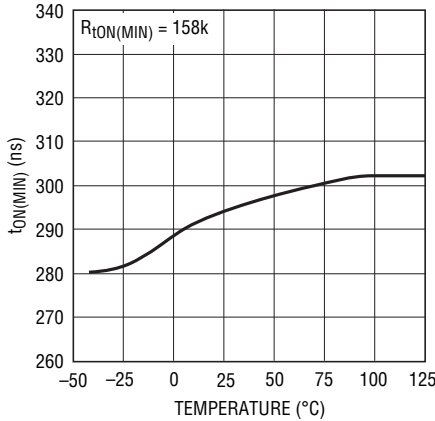

3825 G19

PG Delay Time vs Temperature

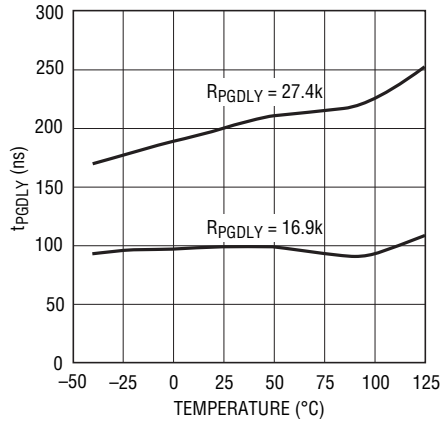

3825 G20

Enable Delay Time vs Temperature

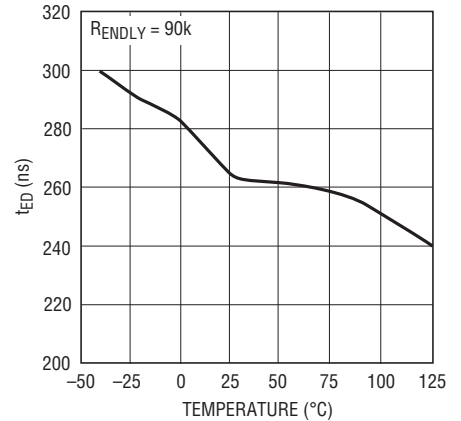

3825 G21

## PIN FUNCTIONS

**SG (Pin 1):** Synchronous Gate Drive Output. This pin provides an output signal for a secondary-side synchronous switch. Large dynamic currents may flow during voltage transitions. See the Applications Information for details.

**V<sub>CC</sub> (Pin 2):** Supply Voltage Pin. Bypass this pin to ground with a 4.7µF capacitor or more. This pin has a 19.5V clamp to ground. V<sub>CC</sub> has an undervoltage lockout function that turns the part on when V<sub>CC</sub> is approximately 15.3V and off at 9.7V. In a conventional “trickle-charge” bootstrapped configuration, the V<sub>CC</sub> supply current increases significantly during turn-on causing a benign relaxation oscillation action on the V<sub>CC</sub> pin if the part does not start normally.

**t<sub>ON</sub> (Pin 3):** Pin for external programming resistor to set the minimum time that the primary switch is on for each cycle. Minimum turn-on facilitates the isolated feedback method. See Applications Information for details.

**ENDLY (Pin 4):** Pin for external programming resistor to set enable delay time. The enable delay time disables the feedback amplifier for a fixed time after the turn-off of the primary-side MOSFET. This allows the leakage inductance voltage spike to be ignored for flyback voltage sensing. See Applications Information for details.

**SYNC (Pin 5):** Pin for synchronizing the internal oscillator with an external clock. The positive edge on a pulse causes the oscillator to discharge causing PG to go low (off) and SG high (on). The sync threshold is typically 1.53V. See Applications Information for details. Tie to ground if unused.

**SFST (Pin 6):** This pin, in conjunction with a capacitor to ground, controls the ramp-up of peak primary current as sensed through the sense resistor. This is used to control converter inrush current at start-up. The V<sub>C</sub> pin voltage cannot exceed the SFST pin voltage, so as SFST increases, the maximum voltage on V<sub>C</sub> increases commensurately, allowing higher peak currents. Total V<sub>C</sub> ramp time is approximately 70ms per µF of capacitance. Leave pin open if not using the soft-start function.

**OSC (Pin 7):** This pin in conjunction with an external capacitor defines the controller oscillator frequency. The frequency is approximately 100kHz • 100/C<sub>OSC</sub>(pF).

**FB (Pin 8):** Pin for the feedback node for the power supply feedback amplifier. Feedback is usually sensed via a third winding and enabled during the flyback period. This pin also sinks additional current to compensate for load current variation as set by the R<sub>COMP</sub> pin. Keep the Thevenin equivalent resistance of the feedback divider at roughly 3k.

3525fe

## PIN FUNCTIONS

**$V_C$  (Pin 9):** Pin used for frequency compensation for the switcher control loop. It is the output of the feedback amplifier and the input to the current comparator. Switcher frequency compensation components are normally placed on this pin to ground. The voltage on this pin is proportional to the peak primary switch current. The feedback amplifier output is enabled during the synchronous switch-on time.

**UVLO (Pin 10):** A resistive divider from  $V_{IN}$  to this pin sets an undervoltage lockout based upon  $V_{IN}$  level (not  $V_{CC}$ ). When the UVLO pin is below its threshold, the gate drives are disabled, but the part draws its normal quiescent current from  $V_{CC}$ . The  $V_{CC}$  undervoltage lockout supersedes this function so  $V_{CC}$  must be great enough to start the part.

The bias current on this pin has hysteresis such that the bias current is sourced when the UVLO threshold is exceeded. This introduces a hysteresis at the pin equivalent to the bias current change times the impedance of the upper divider resistor. The user can control the amount of hysteresis by adjusting the impedance of the divider. See the Applications Information for details. Tie the UVLO pin to  $V_{CC}$  if you are not using this function.

**SENSE<sup>-</sup> (Pin 11), SENSE<sup>+</sup> (Pin 12):** These pins are used to measure primary-side switch current through an external sense resistor. Peak primary-side current is used in the converter control loop. Make Kelvin connections to the sense resistor to reduce noise problems. SENSE<sup>-</sup>

connects to the ground side. At maximum current ( $V_C$  at its maximum voltage) it has a 98mV threshold. The signal is blanked (ignored) during the minimum turn-on time.

**$C_{CMP}$  (Pin 13):** Pin for external filter capacitor for the optional load compensation function. Load compensation reduces the effects of parasitic resistances in the feedback sensing path. A 0.1  $\mu$ F ceramic capacitor suffices for most applications. Short this pin to GND in less demanding applications that don't require load compensation.

**$R_{CMP}$  (Pin 14):** Pin for optional external load compensation resistor. Use of this pin allows for nominal compensation of parasitic resistances in the feedback sensing path. In less demanding applications, this resistor is not needed and this pin can be left open. See Applications Information for details.

**PGDLY (Pin 15):** Pin for external programming resistor to set delay from synchronous gate turn-off to primary gate turn-on. See Applications Information for details.

**PG (Pin 16):** Gate Drive Pin for the Primary-Side MOSFET Switch. Large dynamic currents flow during voltage transitions. See the Applications Information for details.

**GND (Exposed Pad Pin 17):** This is the ground connection for both signal ground and gate driver grounds. This GND must be connected to the PCB ground plane. Careful attention must be paid to ground layout. See Applications Information for details.

**BLOCK DIAGRAM**

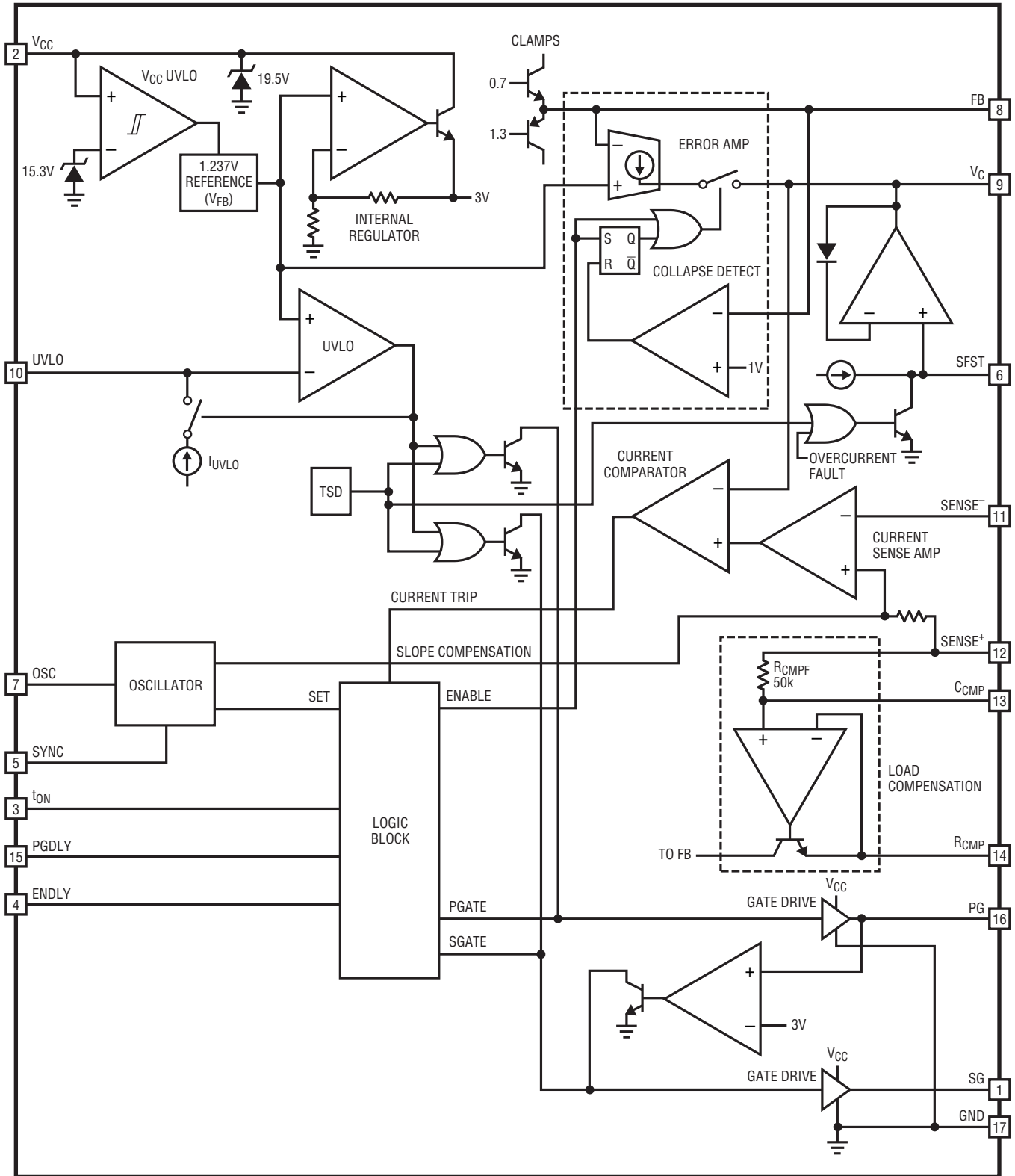



# FLYBACK FEEDBACK AMPLIFIER

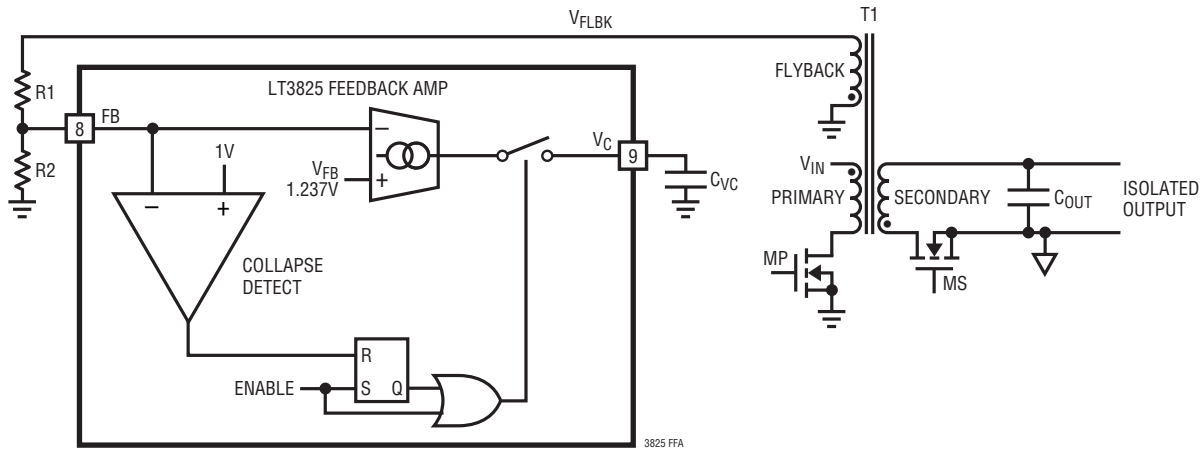

# TIMING DIAGRAM

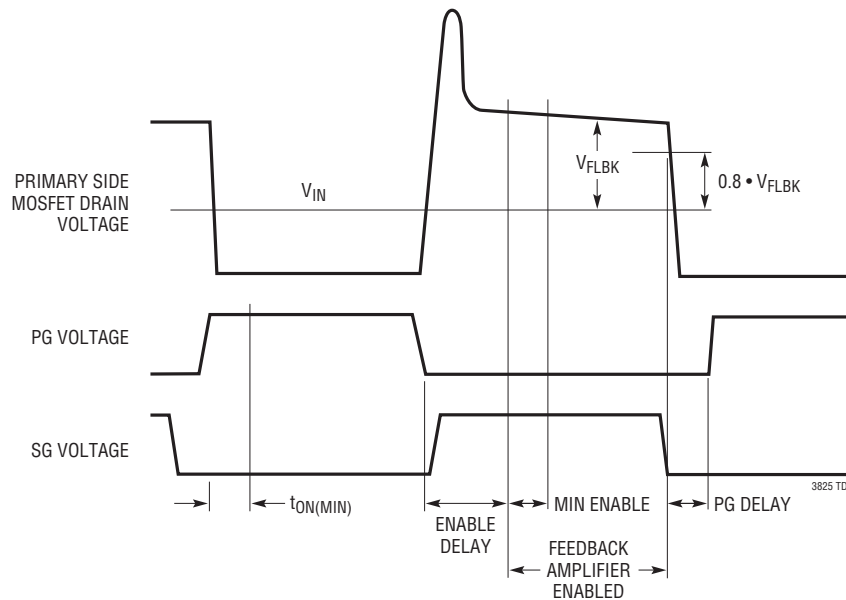

## OPERATION

The LT3825 is a current mode switcher controller IC designed specifically for use in an isolated flyback topology employing synchronous rectification. The LT3825 operation is similar to traditional current mode switchers. The major difference is that output voltage feedback is derived via sensing the output voltage through the transformer. This precludes the need of an opto-isolator in isolated designs greatly improving dynamic response and reliability. The LT3825 has a unique feedback amplifier that samples a transformer winding voltage during the flyback period and uses that voltage to control output voltage.

The internal blocks are similar to many current mode controllers. The differences lie in the flyback feedback amplifier and load compensation circuitry. The logic block also contains circuitry to control the special dynamic requirements of flyback control.

For more information on the basics of current mode switcher/controllers and isolated flyback converters see Application Note 19.

### Feedback Amplifier—Pseudo DC Theory

For the following discussion refer to the simplified Flyback Feedback Amplifier diagram. When the primary-side MOSFET switch MP turns off, its drain voltage rises above the  $V_{IN}$  rail. Flyback occurs when the primary MOSFET is off and the synchronous secondary MOSFET is on. During flyback the voltage on nondriven transformer pins is determined by the secondary voltage. The amplitude of this flyback pulse as seen on the third winding is given as:

$$V_{FLBK} = \frac{V_{OUT} + I_{SEC} \cdot (ESR + R_{DS(ON)})}{N_{SF}}$$

$R_{DS(ON)}$  = on-resistance of the synchronous MOSFET  $M_S$

$I_{SEC}$  = transformer secondary current

ESR = impedance of secondary circuit capacitor, winding and traces

$N_{SF}$  = transformer effective secondary-to-feedback winding turns ratio (i.e.,  $N_S/N_{FLBK}$ )

The flyback voltage is scaled by an external resistive divider  $R1/R2$  and presented at the FB pin. The feedback amplifier

compares the voltage to the internal bandgap reference. The feedback amp is actually a transconductance amplifier whose output is connected to  $V_C$  only during a period in the flyback time. An external capacitor on the  $V_C$  pin integrates the net feedback amp current to provide the control voltage to set the current mode trip point.

The regulation voltage at the FB pin is nearly equal to the bandgap reference  $V_{FB}$  because of the high gain in the overall loop. The relationship between  $V_{FLBK}$  and  $V_{FB}$  is expressed as:

$$V_{FLBK} = \frac{R1 + R2}{R2} \cdot V_{FB}$$

Combining this with the previous  $V_{FLBK}$  expression yields an expression for  $V_{OUT}$  in terms of the internal reference, programming resistors and secondary resistances:

$$V_{OUT} = \left( \frac{R1 + R2}{R2} \cdot V_{FB} \cdot N_{SF} \right) - I_{SEC} \cdot (ESR + R_{DS(ON)})$$

The effect of nonzero secondary output impedance is discussed in further detail; see Load Compensation Theory. The practical aspects of applying this equation for  $V_{OUT}$  are found in the Applications Information.

### Feedback Amplifier Dynamic Theory

So far, this has been a pseudo-DC treatment of flyback feedback amplifier operation. But the flyback signal is a pulse, not a DC level. Provision must be made to enable the flyback amplifier only when the flyback pulse is present. This is accomplished by the “Enable” line in the diagram. Timing signals are then required to enable and disable the flyback amplifier. There are several timing signals which are required for proper LT3825 operation. Please refer to the Timing Diagram.

### Minimum Output Switch On-Time ( $t_{ON(MIN)}$ )

The LT3825 affects output voltage regulation via flyback pulse action. If the output switch is not turned on, there is no flyback pulse and output voltage information is not available. This causes irregular loop response and start-up/latch-up problems. The solution is to require the primary switch to be on for an absolute minimum time per each oscillator cycle. If the output load is less than

## OPERATION

that developed under these conditions, forced continuous operation normally occurs. See Applications Information for further details.

### Enable Delay (ENDLY)

The flyback pulse appears when the primary-side switch shuts off. However, it takes a finite time until the transformer primary-side voltage waveform represents the output voltage. This is partly due to rise time on the primary-side MOSFET drain node but, more importantly, is due to transformer leakage inductance. The latter causes a voltage spike on the primary side, not directly related to output voltage. Some time is also required for internal settling of the feedback amplifier circuitry. In order to maintain immunity to these phenomena, a fixed delay is introduced between the switch turn-off command and the enabling of the feedback amplifier. This is termed “enable delay.” In certain cases where the leakage spike is not sufficiently settled by the end of the enable delay period, regulation error may result. See Applications Information for further details.

### Collapse Detect

Once the feedback amplifier is enabled, some mechanism is then required to disable it. This is accomplished by a collapse detect comparator, which compares the flyback voltage (FB referred) to a fixed reference, nominally 80% of  $V_{FB}$ . When the flyback waveform drops below this level, the feedback amplifier is disabled.

### Minimum Enable Time

The feedback amplifier, once enabled, stays enabled for a fixed minimum time period termed “minimum enable time.” This prevents lockup, especially when the output voltage is abnormally low; e.g., during start-up. The minimum enable time period ensures that the  $V_C$  node is able to “pump up” and increase the current mode trip point to the level where the collapse detect system exhibits proper operation. This time is set internally.

### Effects of Variable Enable Period

The feedback amplifier is enabled during only a portion of the cycle time. This can vary from the fixed minimum enable

time described to a maximum of roughly the “off” switch time minus the enable delay time. Certain parameters of feedback amp behavior are directly affected by the variable enable period. These include effective transconductance and  $V_C$  node slew rate.

### Load Compensation Theory

The LT3825 uses the flyback pulse to obtain information about the isolated output voltage. An error source is caused by transformer secondary current flow through the synchronous MOSFET  $R_{DS(ON)}$  and real life nonzero impedances of the transformer secondary and output capacitor. This was represented previously by the expression “ $I_{SEC} \cdot (ESR + R_{DS(ON)})$ .” However, it is generally more useful to convert this expression to effective output impedance. Because the secondary current only flows during the off portion of the duty cycle (DC), the effective output impedance equals the lumped secondary impedance divided by OFF time DC.

Since the OFF time duty cycle is equal to  $1 - DC$  then:

$$R_{S(OUT)} = \frac{ESR + R_{DS(ON)}}{1 - DC}$$

where:

$R_{S(OUT)}$  = effective supply output impedance

DC = duty cycle

$R_{DS(ON)}$  and ESR are as defined previously

This impedance error may be judged acceptable in less critical applications, or if the output load current remains relatively constant. In these cases the external FB resistive divider is adjusted to compensate for nominal expected error. In more demanding applications, output impedance error is minimized by the use of the load compensation function.

Figure 1 shows the Block Diagram of the load compensation function. Switch current is converted to a voltage by the external sense resistor, averaged and lowpass filtered by the internal 50k resistor  $R_{CMPF}$  and the external capacitor on  $C_{CMP}$ . This voltage is impressed across the external  $R_{CMP}$  resistor by op amp A1 and transistor Q3 producing a current at the collector of Q3 that is subtracted from the FB



## APPLICATIONS INFORMATION

### Transformer Design

Transformer design/specification is the most critical part of a successful application of the LT3825. The following sections provide basic information about designing the transformer and potential trade-offs.

If you need help, the LTC Applications group is available to assist in the choice and/or design of the transformer.

### Turns Ratios

The design of the transformer starts with determining duty cycle (DC). DC impacts the current and voltage stress on the power switches, input and output capacitor RMS currents and transformer utilization (size vs power).

The ideal turns ratio is:

$$N_{\text{IDEAL}} = \frac{V_{\text{OUT}}}{V_{\text{IN}}} \cdot \frac{1 - \text{DC}}{\text{DC}}$$

Avoid extreme duty cycles as they, in general, increase current stresses. A reasonable target for duty cycle is 50% at nominal input voltage.

For instance, if we wanted a 48V to 5V converter at 50% DC then:

$$N_{\text{IDEAL}} = \frac{5}{48} \cdot \frac{1 - 0.5}{0.5} = \frac{1}{9.6}$$

In general, better performance is obtained with a lower turns ratio. A DC of 45.5% yields a 1:8 ratio.

Note the use of the external feedback resistive divider ratio to set output voltage provides the user additional freedom in selecting a suitable transformer turns ratio. Turns ratios that are the simple ratios of small integers; e.g., 1:1, 2:1, 3:2 help facilitate transformer construction and improve performance.

When building a supply with multiple outputs derived through a multiple winding transformer, lower duty cycle can improve cross regulation by keeping the synchronous rectifier on longer, and thus, keep secondary windings coupled longer.

For a multiple output transformer, the turns ratio between output windings is critical and affects the accuracy of the voltages. The ratio between two output voltages is set with the formula  $V_{\text{OUT}2} = V_{\text{OUT}1} \cdot N21$  where N21 is the turns ratio between the two windings. Also keep the secondary MOSFET  $R_{\text{DS(ON)}}$  small to improve cross regulation.

The feedback winding usually provides both the feedback voltage and power for the LT3825. So set the turns ratio between the output and feedback winding to provide a rectified voltage that under worst-case conditions is greater than the 11V maximum  $V_{\text{CC}}$  turn-off voltage.

$$N_{\text{SF}} > \frac{V_{\text{OUT}}}{11 + V_{\text{F}}}$$

$$\text{For our example: } N_{\text{SF}} > \frac{5}{11 + 0.7} = \frac{1}{2.34}$$

We will choose  $\frac{1}{3}$

### Leakage Inductance

Transformer leakage inductance (on either the primary or secondary) causes a spike after the primary-side switch turn-off. This is increasingly prominent at higher load currents, where more stored energy is dissipated. Higher flyback voltage may break down the MOSFET switch if it has too low a  $\text{BV}_{\text{DSS}}$  rating.

One solution to reducing this spike is to use a snubber circuit to suppress the voltage excursion. However, suppressing the voltage extends the flyback pulse width. If the flyback pulse extends beyond the enable delay time, output voltage regulation is affected. The feedback system has a deliberately limited input range, roughly  $\pm 50\text{mV}$  referred to the FB node. This rejects higher voltage leakage spikes because once a leakage spike is several volts in amplitude, a further increase in amplitude has little effect on the feedback system.

Therefore, it is advisable to arrange the snubber circuit to clamp at as high a voltage as possible, observing MOSFET breakdown, such that leakage spike duration is as short as possible. Application Note 19 provides a good reference on snubber design.

## APPLICATIONS INFORMATION

As a rough guide, leakage inductance of several percent (of mutual inductance) or less may require a snubber, but exhibit little to no regulation error due to leakage spike behavior. Inductances from several percent up to perhaps ten percent cause increasing regulation error.

Avoid double digit percentage leakage inductances as there is a potential for abrupt loss of control at high load current. This curious condition potentially occurs when the leakage spike becomes such a large portion of the flyback waveform that the processing circuitry is fooled into thinking that the leakage spike itself is the real flyback signal!

It then reverts to a potentially stable state whereby the top of the leakage spike is the control point, and the trailing edge of the leakage spike triggers the collapse detect circuitry. This typically reduces the output voltage abruptly to a fraction, roughly one-third to two-thirds of its correct value.

Once load current is reduced sufficiently, the system snaps back to normal operation. When using transformers with considerable leakage inductance, exercise this worst-case check for potential bistability:

1. Operate the prototype supply at maximum expected load current.
2. Temporarily short circuit the output.
3. Observe that normal operation is restored.

If the output voltage is found to hang up at an abnormally low value, the system has a problem. This is usually evident by simultaneously viewing the primary-side MOSFET drain voltage to observe firsthand the leakage spike behavior.

A final note—the susceptibility of the system to bistable behavior is somewhat a function of the load current/voltage characteristics. A load with resistive—i.e.,  $I = V/R$  behavior—is the most apt to be bistable. Capacitive loads that exhibit  $I = V^2/R$  behavior are less susceptible.

### Secondary Leakage Inductance

Leakage inductance on the secondary forms an inductive divider on the transformer secondary, reducing the size of the feedback flyback pulse. This increases the output voltage target by a similar percentage.

Note that unlike leakage spike behavior, this phenomenon is independent of load. Since the secondary leakage inductance is a constant percentage of mutual inductance (within manufacturing variations), the solution is to adjust the feedback resistive divider ratio to compensate.

### Winding Resistance Effects

Primary or secondary winding resistance acts to reduce overall efficiency ( $P_{OUT}/P_{IN}$ ). Secondary winding resistance increases effective output impedance degrading load regulation. Load compensation can mitigate this to some extent but a good design keeps parasitic resistances low.

### Bifilar Winding

A bifilar or similar winding is a good way to minimize troublesome leakage inductances. Bifilar windings also improve coupling coefficients and thus improve cross regulation in multiple winding transformers. However, tight coupling usually increases primary-to-secondary capacitance and limits the primary-to-secondary breakdown voltage, so it isn't always practical.

### Primary Inductance

The transformer primary inductance,  $L_P$ , is selected based on the peak-to-peak ripple current ratio ( $X$ ) in the transformer relative to its maximum value. As a general rule, keep  $X$  in the range of 20% to 40% ripple current (i.e.,  $X = 0.2$  to  $0.4$ ). Higher values of ripple will increase conduction losses, while lower values will require larger cores.



## APPLICATIONS INFORMATION

Ripple current and percentage ripple is largest at minimum duty cycle; in other words, at the highest input voltage.  $L_P$  is calculated from:

$$L_P = \frac{(V_{IN(MAX)} \cdot DC_{MIN})^2}{f_{OSC} \cdot X_{MAX} \cdot P_{IN}} = \frac{(V_{IN(MAX)} \cdot DC_{MIN})^2 \cdot Eff}{f_{OSC} \cdot X_{MAX} \cdot P_{OUT}}$$

where:

$f_{OSC}$  is the oscillator frequency

$DC_{MIN}$  is the DC at maximum input voltage

$X_{MAX}$  is ripple current ratio at maximum input voltage

For a 48V ( $V_{IN} = 36V$  to  $72V$ ) to 5V/8A converter with 90% efficiency,  $P_{OUT} = 40W$  and  $P_{IN} = 44.44W$ . Using  $X = 0.4$  and  $f_{OSC} = 200kHz$ :

$$DC_{MIN} = \frac{1}{1 + \frac{N \cdot V_{IN(MAX)}}{V_{OUT}}} = \frac{1}{1 + \frac{1}{8} \cdot \frac{72}{5}} = 35.7\%$$

$$L_P = \frac{(72V \cdot 0.357)^2}{200kHz \cdot 0.4 \cdot 44.44W} = 186\mu H$$

Optimization might show that a more efficient solution is obtained at higher peak current but lower inductance and the associated winding series resistance. A simple spreadsheet program is useful for looking at trade-offs.

### Transformer Core Selection

Once  $L_P$  is known, the type of transformer is selected. High efficiency converters use ferrite cores to minimize core loss. Actual core loss is independent of core size for a fixed inductance, but decreases as inductance increases. Since increased inductance is accomplished through more turns of wire, copper losses increase. Thus transformer design balances core and copper losses. Remember that increased winding resistance will degrade cross regulation and increase the amount of load compensation required.

The main design goals for core selection are reducing copper losses and preventing saturation. Ferrite core material saturates hard, rapidly reducing inductance when the peak design current is exceeded. This results in an abrupt increase in inductor ripple current and, consequently, output voltage ripple. **Do not allow the core to saturate!** The maximum peak primary current occurs at minimum  $V_{IN}$ :

$$I_{PK} = \frac{P_{IN}}{V_{IN(MIN)} \cdot DC_{MAX}} \cdot \left(1 + \frac{X_{MIN}}{2}\right)$$

now :

$$DC_{MAX} = \frac{1}{1 + \frac{N \cdot V_{IN(MIN)}}{V_{OUT}}} = \frac{1}{1 + \frac{1}{8} \cdot \frac{36}{5}} = 52.6\%$$

$$X_{MIN} = \frac{(V_{IN(MIN)} \cdot DC_{MAX})^2}{f_{OSC} \cdot L_P \cdot P_{IN}} = \frac{(36 \cdot 52.6\%)^2}{200kHz \cdot 186\mu H \cdot 44.44} = 0.202$$

Using the example numbers leads to:

$$I_{PK} = \frac{44.44W}{36 \cdot 0.526} \cdot \left(1 + \frac{0.202}{2}\right) = 2.58A$$

### Multiple Outputs

One advantage that the flyback topology offers is that additional output voltages can be obtained simply by adding windings. Designing a transformer for such a situation is beyond the scope of this document. For multiple windings, realize that the flyback winding signal is a combination of activity on all the secondary windings. Thus load regulation is affected by each windings load. Take care to minimize cross regulation effects.

## APPLICATIONS INFORMATION

### Setting Feedback Resistive Divider

The expression for  $V_{OUT}$  developed in the Operation section is rearranged to yield the following expression for the feedback resistors:

$$R1 = R2 \left( \frac{[V_{OUT} + I_{SEC} \cdot (ESR + R_{DS(ON)})]}{V_{FB} \cdot N_{SF}} - 1 \right)$$

Continuing the example, if  $ESR + R_{DS(ON)} = 8m\Omega$ ,  $R2 = 3.32k$ , then:

$$R1 = 3.4k \left( \frac{5 + 8 \cdot 0.008}{1.232 \cdot 1/3} - 1 \right) = 37.6k$$

choose 37.4k.

It is recommended that the Thevenin impedance of the resistive divider ( $R1 || R2$ ) is roughly 3k for bias current cancellation and other reasons.

### Current Sense Resistor Considerations

The external current sense resistor is used to control peak primary switch current, which controls a number of key converter characteristics including maximum power and external component ratings. Use a noninductive current sense resistor (no wire-wound resistors). Mounting the resistor directly above an unbroken ground plane connected with wide and short traces keeps stray resistance and inductance low.

The dual sense pins allow for a fully Kelvined connection. Make sure that  $SENSE^+$  and  $SENSE^-$  are isolated and connect close to the sense resistor to preserve this.

Peak current occurs at 98mV of sense voltage  $V_{SENSE}$ . So the nominal sense resistor is  $V_{SENSE}/I_{PK}$ . For example, a peak switch current of 10A requires a nominal sense resistor of  $0.010\Omega$ . Note that the instantaneous peak power in the sense resistor is 1W, and that it is rated accordingly. The use of parallel resistors can help achieve low resistance, low parasitic inductance and increased power capability.

Size  $R_{SENSE}$  using worst-case conditions, minimum  $L_P$ ,  $V_{SENSE}$  and maximum  $V_{IN}$ . Continuing the example, let us assume that our worst-case conditions yield an  $I_{PK}$  40%

above nominal so  $I_{PK} = 3.64A$ . If there is a 10% tolerance on  $R_{SENSE}$  and minimum  $V_{SENSE} = 80mV$ , then  $R_{SENSE} \cdot 110\% = 80mV/3.64A$  and nominal  $R_{SENSE} = 20m\Omega$ . Round to the nearest available lower value.

### Selecting the Load Compensation Resistor

The expression for  $R_{CMP}$  was derived in the Operation section as:

$$R_{CMP} = K1 \cdot \frac{R_{SENSE} \cdot (1-DC)}{ESR + R_{DS(ON)}} \cdot R1 \cdot N_{SF} = R_{S(OUT)}$$

Continuing the example:

$$K1 = \left( \frac{V_{OUT}}{V_{IN} \cdot Eff} \right) = \frac{5}{48 \cdot 90\%} = 0.116$$

If  $ESR + R_{DS(ON)} = 8m\Omega$

$$R_{CMP} = 0.116 \cdot \frac{20m\Omega \cdot (1-0.455)}{8m\Omega} \cdot 37.4k\Omega = 1.96k$$

This value for  $R_{CMP}$  is a good starting point, but empirical methods are required for producing the best results. This is because several of the required input variables are difficult to estimate precisely. For instance, the ESR term above includes that of the transformer secondary, but its effective ESR value depends on high frequency behavior, not simply DC winding resistance. Similarly,  $K1$  appears as a simple ratio of  $V_{IN}$  to  $V_{OUT}$  times (differential) efficiency, but theoretically estimating efficiency is not a simple calculation.

The suggested empirical method is as follows:

1. Build a prototype of the desired supply including the actual secondary components.
2. Temporarily ground the  $C_{CMP}$  pin to disable the load compensation function. Measure output voltage while sweeping output current over the expected range. Approximate the voltage variation as a straight line,  $\Delta V_{OUT}/\Delta I_{OUT} = R_{S(OUT)}$ .
3. Calculate a value for the  $K1$  constant based on  $V_{IN}$ ,  $V_{OUT}$  and the measured efficiency.



## APPLICATIONS INFORMATION

4. Compute:

$$R_{CMP} = K1 \cdot \frac{R_{SENSE}}{R_{S(OUT)}} \cdot R1 \cdot N_{SF}$$

5. Verify this result by connecting a resistor of this value from the  $R_{CMP}$  pin to ground.

6. Disconnect the ground short to  $C_{CMP}$  and connect a 0.1  $\mu$ F filter capacitor to ground. Measure the output impedance  $R_{S(OUT)} = \Delta V_{OUT} / \Delta I_{OUT}$  with the new compensation in place.  $R_{S(OUT)}$  should have decreased significantly. Fine tuning is accomplished experimentally by slightly altering  $R_{CMP}$ . A revised estimate for  $R_{CMP}$  is:

$$R'_{CMP} = R_{CMP} \cdot \left( 1 + \frac{R_{S(OUT)CMP}}{R_{S(OUT)}} \right)$$

where  $R'_{CMP}$  is the new value for the load compensation resistor,  $R_{S(OUT)CMP}$  is the output impedance with  $R_{CMP}$  in place and  $R_{S(OUT)}$  is the output impedance with no load compensation (from step 2).

### Setting Frequency

The switching frequency of the LT3825 is set by an external capacitor connected between the OSC pin and ground. Recommended values are between 200pF and 33pF, yielding switching frequencies between 50kHz and 250kHz. Figure 2 shows the nominal relationship between external capacitance and switching frequency. Place the capacitor as close as possible to the IC and minimize OSC trace length and area to minimize stray capacitance and potential noise pickup.

You can synchronize the oscillator frequency to an external frequency. This is done with a signal on the SYNC pin. Set the LT3825 frequency 10% slower than the desired external frequency using the OSC pin capacitor, then use a pulse on the SYNC pin of amplitude greater than 2V and with the desired frequency. The rising edge of the SYNC signal initiates an OSC capacitor discharge forcing primary MOSFET off (PG voltage goes low). If the oscillator frequency is much different from the sync frequency, problems may occur with slope compensation and system stability. Keep the sync pulse width greater than 500ns.

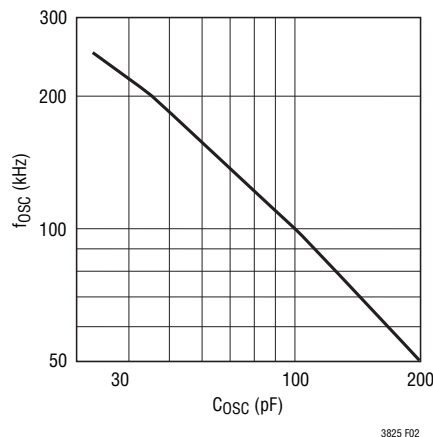

Figure 2.  $f_{osc}$  vs OSC Capacitor Values

### Selecting Timing Resistors

There are three internal “one-shot” times that are programmed by external application resistors: minimum on-time, enable delay time and primary MOSFET turn-on delay. These are all part of the isolated flyback control technique, and their functions are previously outlined in the Theory of Operation section.

The following information should help in selecting and/or optimizing these timing values.

### Minimum On-Time ( $t_{ON(MIN)}$ )

Minimum on-time is the programmable period during which current limit is blanked (ignored) after the turn on of the primary-side switch. This improves regulator performance by eliminating false tripping on the leading edge spike in the switch, especially at light loads. This spike is due to both the gate/source charging current and the discharge of drain capacitance. The isolated flyback sensing requires a pulse to sense the output. Minimum on-time ensures that there is always a signal to close the loop.

The LT3825 does not employ cycle skipping at light loads. Therefore, minimum on-time along with synchronous rectification sets the switch over to forced continuous mode operation.

## APPLICATIONS INFORMATION

The  $t_{ON(MIN)}$  resistor is set with the following equation:

$$R_{tON(MIN)} (k\Omega) = \frac{t_{ON(MIN)}(ns) - 104}{1.063}$$

Keep  $R_{tON(MIN)}$  greater than 70k. A good starting value is 160k.

### Enable Delay Time (ENDLY)

Enable delay time provides a programmable delay between turn-off of the primary gate drive node and the subsequent enabling of the feedback amplifier. As discussed earlier, this delay allows the feedback amplifier to ignore the leakage inductance voltage spike on the primary side.

The worst-case leakage spike pulse width is at maximum load conditions. So set the enable delay time at these conditions.

While the typical applications for this part use forced continuous operation, it is conceivable that a secondary-side controller might cause discontinuous operation at light loads. Under such conditions the amount of energy stored in the transformer is small. The flyback waveform becomes “lazy” and some time elapses before it indicates the actual secondary output voltage. The enable delay time should be made long enough to ignore the “irrelevant” portion of the flyback waveform at light load.

Even though the LT3825 has a robust gate drive, the gate transition time slows with very large MOSFETs. Increase delay time as required when using such MOSFETs.

The enable delay resistor is set with the following equation:

$$R_{ENDLY} (k\Omega) = \frac{t_{ENDLY}(ns) - 30}{2.616}$$

Keep  $R_{ENDLY}$  greater than 40k. A good starting point is 56k.

### Primary Gate Delay Time (PGDLY)

Primary gate delay is the programmable time from the turn-off of the synchronous MOSFET to the turn-on of the primary-side MOSFET. Correct setting eliminates overlap between the primary-side switch and secondary-

side synchronous switch(es) and the subsequent current spike in the transformer. This spike will cause additional component stress and a loss in regulator efficiency.

The primary gate delay resistor is set with the following equation:

$$R_{PGDLY} (k\Omega) = \frac{t_{PGDLY}(ns) + 47}{9.01}$$

A good starting point is 27k.

### Soft-Start Functions

The LT3825 contains an optional soft-start function that is enabled by connecting an external capacitor between the SFST pin and ground. Internal circuitry prevents the control voltage at the  $V_C$  pin from exceeding that on the SFST pin. There is an initial pull-up circuit to quickly bring the SFST voltage to approximately 0.8V. From there it charges to approximately 2.8V with a 20 $\mu$ A current source.

The SFST node is discharged to 0.8V when a fault occurs. A fault is  $V_{CC}$  too low (undervoltage lockout), current sense voltage greater than 200mV or the IC’s thermal (over temperature) shutdown is tripped. When SFST discharges, the  $V_C$  node voltage is also pulled low to below the minimum current voltage. Once discharged and the fault removed, the SFST recharges up again.

In this manner, switch currents are reduced and the stresses in the converter are reduced during fault conditions.

The time it takes to fully charge soft-start is:

$$t_{SS} = \frac{C_{SFST} \cdot 1.4V}{20\mu A} = 70ms \cdot C_{SFST} (\mu F)$$

### UVLO Pin Function

The UVLO pin provides a user programming undervoltage lockout. This is typically used to provide undervoltage lockout based on  $V_{IN}$ . The gate drivers are disabled when UVLO is below the 1.24V UVLO threshold. An external resistive divider between the input supply and ground is used to set the turn-on voltage.

## APPLICATIONS INFORMATION

The bias current on this pin depends on the pin voltage and UVLO state. The change provides the user with adjustable UVLO hysteresis. When the pin rises above the UVLO threshold a small current is sourced out of the pin, increasing the voltage on the pin. As the pin voltage drops below this threshold, the current is stopped, further dropping the voltage on UVLO. In this manner, hysteresis is produced.

Referring to Figure 3, the voltage hysteresis at  $V_{IN}$  is equal to the change in bias current times  $R_A$ . The design procedure is to select the desired  $V_{IN}$  referred voltage hysteresis,  $V_{UVHYS}$ . Then:

$$R_A = \frac{V_{UVHYS}}{I_{UVLO}}$$

where:

$$I_{UVLO} = I_{UVLOL} - I_{UVLOH} \text{ is approximately } 3.4\mu\text{A}$$

$R_B$  is then selected with the desired turn-on voltage:

$$R_B = \frac{R_A}{\left(\frac{V_{IN(ON)}}{V_{UVLO}} - 1\right)}$$

If we wanted a  $V_{IN}$ -referred trip point of 36V, with 1.8V (5%) of hysteresis (on at 36V, off at 34.2V):

$$R_A = \frac{1.8\text{V}}{3.4\mu\text{A}} = 529\text{k}, \text{ use } 523\text{k}$$

$$R_B = \frac{523\text{k}}{\left(\frac{36\text{V}}{1.23\text{V}} - 1\right)} = 18.5\text{k}, \text{ use } 18.7\text{k}$$

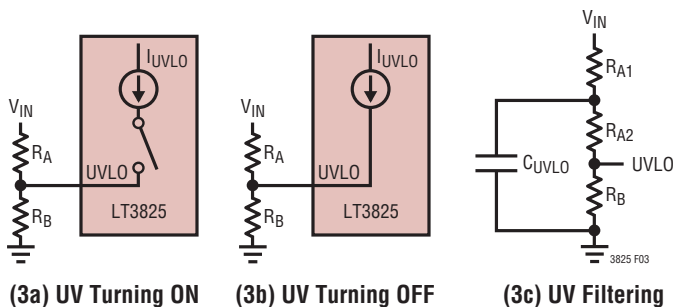

Figure 3

Even with good board layout, board noise may cause problems with UVLO. You can filter the divider but keep large capacitance off the UVLO node because it will slow the hysteresis produced from the change in bias current. Figure 3c shows an alternate method of filtering by splitting the  $R_A$  resistor with the capacitor. The split should put more of the resistance on the UVLO side.

### Converter Start-Up

The standard topology for the LT3825 utilizes a third transformer winding on the primary side that provides both feedback information and local  $V_{CC}$  power for the LT3825 (see Figure 4). This power “bootstrapping” improves converter efficiency but is not inherently self-starting. Start-up is affected with an external “trickle-charge” resistor and the LT3825’s internal  $V_{CC}$  undervoltage lockout circuit. The  $V_{CC}$  undervoltage lockout has wide hysteresis to facilitate start-up.

In operation, the “trickle charge” resistor,  $R_{TR}$ , is connected to  $V_{IN}$  and supplies a small current, typically on the order of 1mA to charge  $C_{TR}$ . Initially the LT3825 is off and draws only its start-up current. When  $C_{TR}$  reaches the  $V_{CC}$  turn-on threshold voltage the LT3825 turns on abruptly and draws its normal supply current.

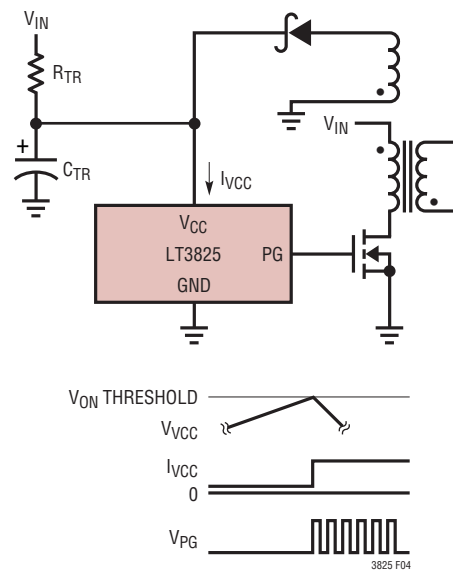

Figure 4. Typical Power Bootstrapping

## APPLICATIONS INFORMATION

Switching action commences and the converter begins to deliver power to the output. Initially the output voltage is low and the flyback voltage is also low, so  $C_{TR}$  supplies most of the LT3825 current (only a fraction comes from  $R_{TR}$ .)  $V_{CC}$  voltage continues to drop until after some time, typically tens of milliseconds, the output voltage approaches its desired value. The flyback winding then provides the LT3825 supply current and the  $V_{CC}$  voltage stabilizes.

If  $C_{TR}$  is undersized,  $V_{CC}$  reaches the  $V_{CC}$  turn-off threshold before stabilization and the LT3825 turns off. The  $V_{CC}$  node then begins to charge back up via  $R_{TR}$  to the turn-on threshold, where the part again turns on. Depending upon the circuit, this may result in either several on-off cycles before proper operation is reached, or permanent relaxation oscillation at the  $V_{CC}$  node.

$R_{TR}$  is selected to yield a worst-case minimum charging current greater than the maximum rated LT3825 start-up current, and a worst-case maximum charging current less than the minimum rated LT3825 supply current.

$$R_{TR(MAX)} < \frac{V_{IN(MIN)} - V_{CC(ON\_MAX)}}{I_{CC(ST\_MAX)}}$$

and

$$R_{TR(MIN)} > \frac{V_{IN(MAX)} - V_{CC(ON\_MIN)}}{I_{CC(MIN)}}$$

Make  $C_{TR}$  large enough to avoid the relaxation oscillatory behavior described above. This is complicated to determine theoretically as it depends on the particulars of the secondary circuit and load behavior. Empirical testing is recommended. Note that the use of the optional soft-start function lengthens the power-up timing and requires a correspondingly larger value for  $C_{TR}$ .

If you have an available input voltage within the  $V_{CC}$  range, the internal wide hysteresis range UVLO function becomes counterproductive. In such cases it is better to operate the LT3825 directly from the available supply. In this case, use the LT3837 which is identical to the LT3825 except that it lacks the internal  $V_{CC}$  undervoltage lockout function. It is designed to operate directly from supplies in the range of 4.5V to 19V. See the LT3837 data sheet for further information.

The LT3825 has an internal clamp on  $V_{CC}$  of approximately 19.5V. This provides some protection for the part in the event that the switcher is off (UVLO low) and the  $V_{CC}$  node is pulled high. If  $R_{TR}$  is sized correctly the part should never attain this clamp voltage.

### Control Loop Compensation

Loop frequency compensation is performed by connecting a capacitor network from the output of the feedback amplifier ( $V_C$  pin) to ground as shown in Figure 5. Because of the sampling behavior of the feedback amplifier, compensation is different from traditional current mode switcher controllers. Normally only  $C_{VC}$  is required.  $R_{VC}$  can be used to add a “zero” but the phase margin improvement traditionally offered by this extra resistor is usually already accomplished by the nonzero secondary circuit impedance.  $C_{VC2}$  can be used to add an additional high frequency pole and is usually sized at 0.1 times  $C_{VC}$ .

In further contrast to traditional current mode switchers,  $V_C$  pin ripple is generally not an issue with the LT3825. The dynamic nature of the clamped feedback amplifier forms an effective track/hold type response, whereby the  $V_C$  voltage changes during the flyback pulse, but is then “held” during the subsequent “switch-on” portion of the next cycle. This action naturally holds the  $V_C$  voltage stable

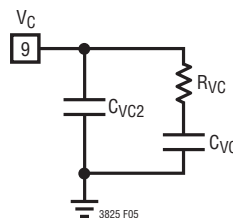

Figure 5.  $V_C$  Compensation Network

## APPLICATIONS INFORMATION

during the current comparator sense action (current mode switching).

AN19 provides a method for empirically tweaking frequency compensation. Basically it involves introducing a load current step and monitoring the response.

### Slope Compensation

This part incorporates current slope compensation. Slope compensation is required to ensure current loop stability when the DC is greater than 50%. In some switcher controllers, slope compensation reduces the maximum peak current at higher duty cycles. The LT3825 eliminates this problem by having circuitry that compensates for the slope compensation so that maximum current sense voltage is constant across all duty cycles.

### Minimum Load Considerations

At light loads, the LT3825 derived regulator goes into forced continuous conduction mode. The primary-side switch always turns on for a short time as set by the  $t_{ON(MIN)}$  resistor. If this produces more power than the load requires, power will flow back into the primary during the “off” period when the synchronization switch is on. This does not produce any inherently adverse problems, though light load efficiency is reduced.

### Maximum Load Considerations

The current mode control uses the  $V_C$  node voltage and amplified sense resistor voltage as inputs to the current comparator. When the amplified sense voltage exceeds the  $V_C$  node voltage, the primary-side switch is turned off.

In normal use, the peak switch current increases while FB is below the internal reference. This continues until  $V_C$  reaches its 2.56V clamp. At clamp, the primary-side MOSFET will turn off at the rated 98mV  $V_{SENSE}$  level. This repeats on the next cycle.

It is possible for the peak primary switch currents as referred across  $R_{SENSE}$  to exceed the max 98mV rating because of the minimum switch-on time blanking. If the voltage on  $V_{SENSE}$  exceeds 206mV after the minimum turn-on time, the SFST capacitor is discharged, causing the discharge of the  $V_C$  capacitor. This then reduces the peak current on the next cycle and will reduce overall stress in the primary switch.

### Short-Circuit Conditions

Loss of current limit is possible under certain conditions such as an output short circuit. If the duty cycle exhibited by the minimum on time is greater than the ratio of secondary winding voltage (referred-to-primary) divided by input voltage, then peak current is not controlled at the nominal value. It ratchets up cycle-by-cycle to some higher level. Expressed mathematically, the requirement to maintain short-circuit control is:

$$DC_{MIN} = t_{ON(MIN)} \cdot f_{OSC} < \frac{I_{SC} \cdot (R_{SEC} + R_{DS(ON)})}{V_{IN} \cdot N_{SP}}$$

where:

$t_{ON(MIN)}$  = primary-side switch minimum on-time

$I_{SC}$  = short-circuit output current

$N_{SP}$  = secondary-to-primary turns ratio ( $N_{SEC}/N_{PRI}$ )

Other variables as previously defined

Trouble is typically encountered only in applications with a relatively high product of input voltage times secondary-to-primary turns ratio and/or a relatively long minimum switch on time. Additionally, several real world effects such as transformer leakage inductance, AC winding losses, and output switch voltage drop combine to make this simple theoretical calculation a conservative estimate. Prudent design evaluates the switcher for short-circuit protection and adds any additional circuitry to prevent destruction.



## APPLICATIONS INFORMATION

### Output Voltage Error Sources

The LT3825's feedback sensing introduces additional sources of errors. The following is a summary list.

The internal bandgap voltage reference sets the reference voltage for the feedback amplifier. The specifications detail its variation.

The external feedback resistive divider ratio proportional directly affects regulated voltage. Use 1% components.

Leakage inductance on the transformer secondary reduces the effective secondary-to-feedback winding turns ratio ( $N_S/N_F$ ) from its ideal value. This increases the output voltage target by a similar percentage. Since secondary leakage inductance is constant from part to part (with a tolerance) adjust the feedback resistor ratio to compensate.

The transformer secondary current flows through the impedances of the winding resistance, synchronous MOSFET  $R_{DS(ON)}$  and output capacitor ESR. The DC equivalent current for these errors is higher than the load current because conduction occurs only during the converter's "off" time. So divide the load current by  $(1 - DC)$ .

If the output load current is relatively constant, the feedback resistive divider is used to compensate for these losses. Otherwise, use the LT3825 load compensation circuitry (see Load Compensation).

If multiple output windings are used, the flyback winding will have a signal that represents an amalgamation of all these windings impedances. Take care that you examine worst-case loading conditions when tweaking the voltages.

### Power MOSFET Selection

The power MOSFETs are selected primarily on the criteria of on-resistance,  $R_{DS(ON)}$ , input capacitance, drain-to-source breakdown voltage ( $BV_{DSS}$ ), maximum gate voltage ( $V_{GS}$ ) and maximum drain current ( $I_{D(MAX)}$ ).

For the primary-side power MOSFET, the peak current is:

$$I_{PK(PRI)} = \frac{P_{IN}}{V_{IN(MIN)} \cdot DC_{MAX}} \cdot \left(1 + \frac{X_{MIN}}{2}\right)$$

where  $X_{MIN}$  is peak-to-peak current ratio as defined earlier.

For each secondary-side power MOSFET, the peak current is:

$$I_{PK(SEC)} = \frac{I_{OUT}}{1 - DC_{MAX}} \cdot \left(1 + \frac{X_{MIN}}{2}\right)$$

Select a primary-side power MOSFET with a  $BV_{DSS}$  greater than:

$$BV_{DSS} \geq I_{PK} \sqrt{\frac{L_{LKG}}{C_P}} + V_{IN(MAX)} + \frac{V_{OUT(MAX)}}{N_{SP}}$$

where  $N_{SP}$  reflects the turns ratio of that secondary-to-primary winding.  $L_{LKG}$  is the primary-side leakage inductance and  $C_P$  is the primary-side capacitance (mostly from the  $C_{OSS}$  of the primary-side power MOSFET). A snubber may be added to reduce the leakage inductance as discussed earlier.

For each secondary-side power MOSFET, the  $BV_{DSS}$  should be greater than:

$$BV_{DSS} \geq V_{OUT} + V_{IN(MAX)} \cdot N_{SP}$$

Choose the primary-side MOSFET  $R_{DS(ON)}$  at the nominal gate drive voltage (7.5V). The secondary side MOSFET gate drive voltage depends on the gate drive method.

Primary-side power MOSFET RMS current is given by:

$$I_{RMS(PRI)} = \frac{P_{IN}}{V_{IN(MIN)} \sqrt{DC_{MAX}}}$$

For each secondary-side power MOSFET RMS current is given by:

$$I_{RMS(SEC)} = \frac{I_{OUT}}{\sqrt{1 - DC_{MAX}}}$$

Calculate MOSFET power dissipation next. Because the primary-side power MOSFET operates at high  $V_{DS}$ , a transition power loss term is included for accuracy.  $C_{MILLER}$  is the most critical parameter in determining the transition loss, but is not directly specified on the data sheets.

## APPLICATIONS INFORMATION

$C_{MILLER}$  is calculated from the gate charge curve included on most MOSFET data sheets (Figure 6).

The flat portion of the curve is the result of the Miller (gate-to-drain) capacitance as the drain voltage drops. The Miller capacitance is computed as:

$$C_{MILLER} = \frac{Q_B - Q_A}{V_{DS}}$$

The curve is done for a given  $V_{DS}$ . The Miller capacitance for different  $V_{DS}$  voltages are estimated by multiplying the computed  $C_{MILLER}$  by the ratio of the application  $V_{DS}$  to the curve specified  $V_{DS}$ .

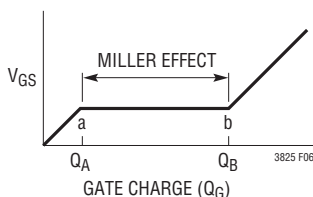

Figure 6. Gate Charge Curve

With  $C_{MILLER}$  determined, calculate the primary-side power MOSFET power dissipation:

$$P_{DPRI} = I_{RMS(PRI)}^2 \cdot R_{DS(ON)} (1 + \delta) +$$

$$V_{IN(MAX)} \cdot \frac{P_{IN(MAX)}}{DC_{MIN}} \cdot R_{DR} \cdot \frac{C_{MILLER}}{V_{GATE(MAX)} - V_{TH}} \cdot f_{OSC}$$

where:

$R_{DR}$  is the gate driver resistance ( $\approx 10\Omega$ )

$V_{TH}$  is the MOSFET gate threshold voltage

$f_{OSC}$  is the operating frequency

$V_{GATE(MAX)} = 7.5V$  for this part

$(1 + \delta)$  is generally given for a MOSFET in the form of a normalized  $R_{DS(ON)}$  vs temperature curve. If you don't have a curve, use  $\delta = 0.005/^\circ C \cdot \Delta T$  for low voltage MOSFETs.

The secondary-side power MOSFETs typically operate at substantially lower  $V_{DS}$ , so you can neglect transition losses. The dissipation is calculated using:

$$P_{D(SEC)} = I_{RMS(SEC)}^2 \cdot R_{DS(ON)} (1 + \delta)$$

With power dissipation known, the MOSFETs' junction temperatures are obtained from the equation:

$$T_J = T_A + P_D \cdot \theta_{JA}$$

where  $T_A$  is the ambient temperature and  $\theta_{JA}$  is the MOSFET junction-to-ambient thermal resistance.

Once you have  $T_J$ , iterate your calculations recomputing  $\delta$  and power dissipations until convergence.

### Gate Drive Node Consideration

The PG and SG gate drivers are strong drives to minimize gate drive rise and fall times. This improves efficiency but the high frequency components of these signals can cause problems. Keep the traces short and wide to reduce parasitic inductance.

The parasitic inductance creates an LC tank with the MOSFET gate capacitance. In less than ideal layouts, a series resistance of  $5\Omega$  or more may help to dampen the ringing at the expense of slightly slower rise and fall times and efficiency.

The LT3825 gate drives will clamp the max gate voltage to roughly 7.4V, so you can safely use MOSFETs with max  $V_{GS}$  of 10V or larger.

### Synchronous Gate Drive

There are several different ways to drive the synchronous gate MOSFET. Full converter isolation requires the synchronous gate drive to be isolated. This is usually accomplished by way of a pulse transformer. Usually the pulse driver is used to drive a buffer on the secondary as shown in the application on the front page of this data sheet.

However, other schemes are possible. There are gate drivers and secondary side synchronous controllers available that provide the buffer function as well as additional features.

## APPLICATIONS INFORMATION

### Capacitor Selection

In a flyback converter, the input and output current flows in pulses, placing severe demands on the input and output filter capacitors. The input and output filter capacitors are selected based on RMS current ratings and ripple voltage.

Select an input capacitor with a ripple current rating greater than:

$$I_{RMS} = \frac{P_{IN}}{V_{IN(MIN)}} \sqrt{\frac{1-DC_{MAX}}{DC_{MAX}}}$$

Continuing the example:

$$I_{RMS} = \frac{44.4W}{36V} \sqrt{\frac{1-52.6\%}{52.6\%}} = 1.17A$$

Keep input capacitor series resistance (ESR) and inductance (ESL) small, as they affect electromagnetic interference suppression. In some instances, high ESR can also produce stability problems because flyback converters exhibit a negative input resistance characteristic. Refer to Application Note 19 for more information.

The output capacitor is sized to handle the ripple current and to ensure acceptable output voltage ripple.

The output capacitor should have an RMS current rating greater than:

$$I_{RMS} = I_{OUT} \sqrt{\frac{DC_{MAX}}{1-DC_{MAX}}}$$

Continuing the example:

$$I_{RMS} = 8A \sqrt{\frac{52.6\%}{1-52.6\%}} = 8.43A$$

This is calculated for each output in a multiple winding application.

ESR and ESL along with bulk capacitance directly affect the output voltage ripple. The waveforms for a typical flyback converter are illustrated in Figure 7.

The maximum acceptable ripple voltage (expressed as a percentage of the output voltage) is used to establish a starting point for the capacitor values. For the purpose of simplicity we will choose 2% for the maximum output ripple, divided equally between the ESR step and the charging/discharging  $\Delta V$ . This percentage ripple changes, depending on the requirements of the application. You can modify the equations below.

For a 1% contribution to the total ripple voltage, the ESR of the output capacitor is determined by:

$$ESR_{COUT} \leq 1\% \cdot \frac{V_{OUT} \cdot (1-DC_{MAX})}{I_{OUT}}$$

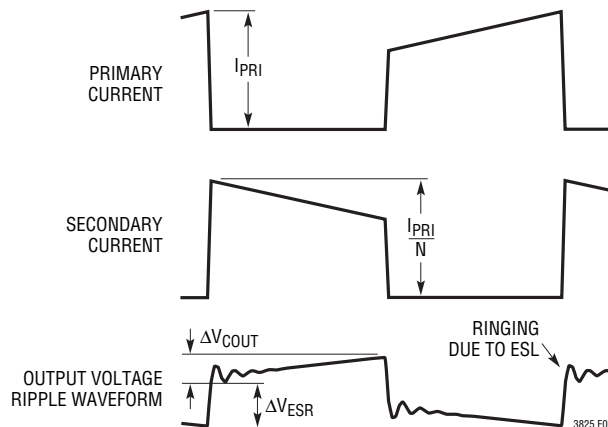

Figure 7. Typical Flyback Converter Waveforms



## APPLICATIONS INFORMATION

The other 1% is due to the bulk C component, so use:

$$C_{OUT} \geq \frac{I_{OUT}}{1\% \cdot V_{OUT} \cdot f_{OSC}}$$

In many applications the output capacitor is created from multiple capacitors to achieve desired voltage ripple, reliability and cost goals. For example, a low ESR ceramic capacitor can minimize the ESR step, while an electrolytic capacitor satisfies the required bulk C.

Continuing our example, the output capacitor needs:

$$ESR_{C_{OUT}} \leq 1\% \cdot \frac{5V \cdot (1 - 49\%)}{8A} = 3m\Omega$$

$$C_{OUT} \geq \frac{8A}{1\% \cdot 5 \cdot 200kHz} = 800\mu F$$

These electrical characteristics require paralleling several low ESR capacitors possibly of mixed type.

Most capacitor ripple current ratings are based on 2000 hour life. This makes it advisable to derate the capacitor or to choose a capacitor rated at a higher temperature than required.

One way to reduce cost and improve output ripple is to use a simple LC filter. Figure 8 shows an example of the filter.

The design of the filter is beyond the scope of this data sheet. However, as a starting point, use these general guide lines. Start with a  $C_{OUT}$  1/4 the size of the nonfilter solution. Make C1 1/4 of  $C_{OUT}$  to make the second filter pole independent of  $C_{OUT}$ . C1 may be best implemented with multiple ceramic capacitors. Make L1 smaller than the output inductance of the transformer. In general, a 0.1 $\mu$ H filter inductor is sufficient. Add a small ceramic capacitor ( $C_{OUT2}$ ) for high frequency noise on  $V_{OUT}$ . For those interested in more details refer to "Second-Stage

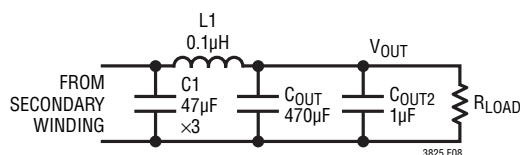

Figure 8

LC Filter Design," Ridley, Switching Power Magazine, July 2000, p8-10.

Circuit simulation is a way to optimize output capacitance and filters, just make sure to include the component parasitics. LTC SwitcherCAD™ is a terrific free circuit simulation tool that is available at [www.linear.com](http://www.linear.com). Final optimization of output ripple must be done on a dedicated PC board. Parasitic inductance due to poor layout can significantly impact ripple. Refer to the PC Board Layout section for more details.

### IC Thermal Considerations

Take care to ensure that the LT3825 junction temperature does not exceed 125°C. Power is computed from the average supply current, the sum of quiescent supply current ( $I_{CC}$  in the specifications) plus gate drive currents.

The primary gate drive current is computed as:

$$f_{OSC} \cdot Q_G$$

where  $Q_G$  is the total gate charge at max  $V_{GS}$  (obtained from the gate charge curve) and  $f$  is the switching frequency.

Since the synchronous driver is usually driving a capacitive load, the synchronous gate drive power dissipation is:

$$f_{OSC} \cdot C_S \cdot V_{SGMAX}$$

where  $C_S$  is the SG capacitive load and  $V_{SGMAX}$  is the SG pin max voltage.

The total IC dissipation is computed as:

$$P_{D(TOTAL)} = V_{CC} \cdot (I_{CC} + f_{OSC} \cdot (Q_{GPRI} + C_S \cdot V_{SGMAX}))$$

$V_{CC}$  is the worst-case LT3825 supply voltage.

Junction temperature is computed as:

$$T_J = T_A + P_D \cdot \theta_{JA}$$

where:

$T_A$  is the ambient temperature

$\theta_{JA}$  is the FE16 package junction-to-ambient thermal impedance (40°C/W).

## APPLICATIONS INFORMATION

### PC Board Layout Considerations

In order to minimize switching noise and improve output load regulation, connect the GND pin of the LT3825 directly to the ground terminal of the  $V_{CC}$  decoupling capacitor, the bottom terminal of the current sense resistor, the ground terminal of the input capacitor, and the ground plane (multiple vias). Place the  $V_{CC}$  capacitor immediately adjacent to the  $V_{CC}$  and GND pins on the IC package. This capacitor carries high di/dt MOSFET gate drive currents. Use a low ESR ceramic capacitor.

Take care in PCB layout to keep the traces that conduct high switching currents short, wide and with minimal overall loop area. These are typically the traces associated with the switches. This reduces the parasitic inductance and also minimizes magnetic field radiation. Figure 9 outlines the critical paths.

Keep electric field radiation low by minimizing the length and area of traces (keep stray capacitances low). The drain of the primary-side MOSFET is the worst offender in this category. Always use a ground plane under the switcher circuitry to prevent coupling between PCB planes.

Check that the maximum  $BV_{DSS}$  ratings of the MOSFETs are not exceeded due to inductive ringing. This is done by viewing the MOSFET node voltages with an oscilloscope. If it is breaking down either choose a higher voltage device, add a snubber or specify an avalanche-rated MOSFET.

Place the small-signal components away from high frequency switching nodes. This allows the use of a pseudo-Kelvin connection for the signal ground, where high di/dt gate driver currents flow out of the IC ground pin in one direction (to the bottom plate of the  $V_{CC}$  decoupling capacitor) and small-signal currents flow in the other direction.

Keep the trace from the feedback divider tap to the FB pin short to preclude inadvertent pickup.

For applications with multiple switching power converters connected to the same input supply, make sure that the input filter capacitor for the LT3825 is not shared with other converters. AC input current from another converter could cause substantial input voltage ripple and this could interfere with the LT3825 operation. A few inches of PC trace or wire ( $L \cong 100nH$ ) between the  $C_{IN}$  of the LT3825 and the actual source  $V_{IN}$  is sufficient to prevent current sharing problems.

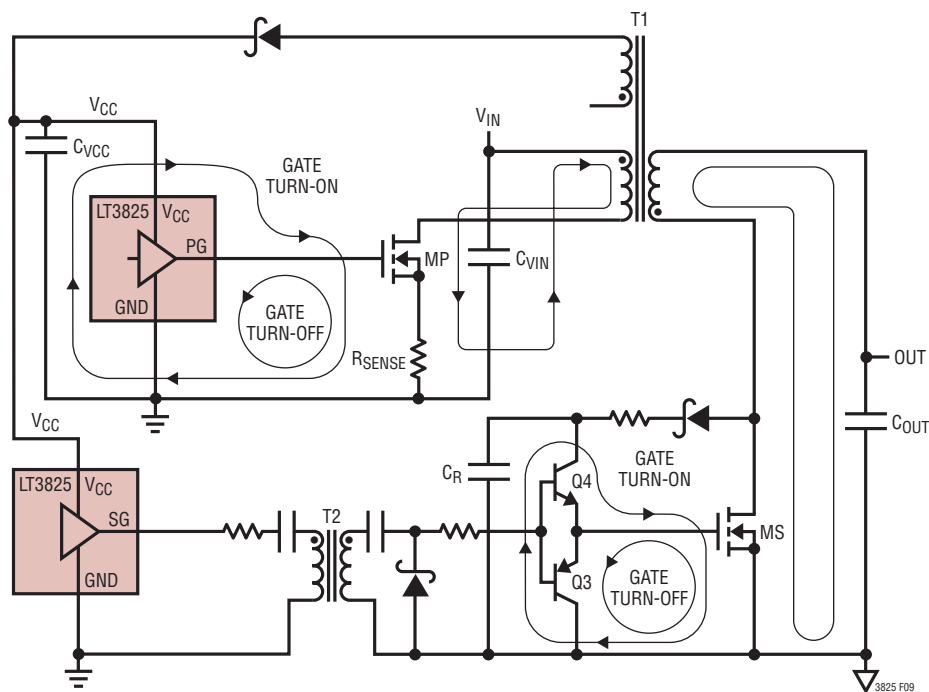
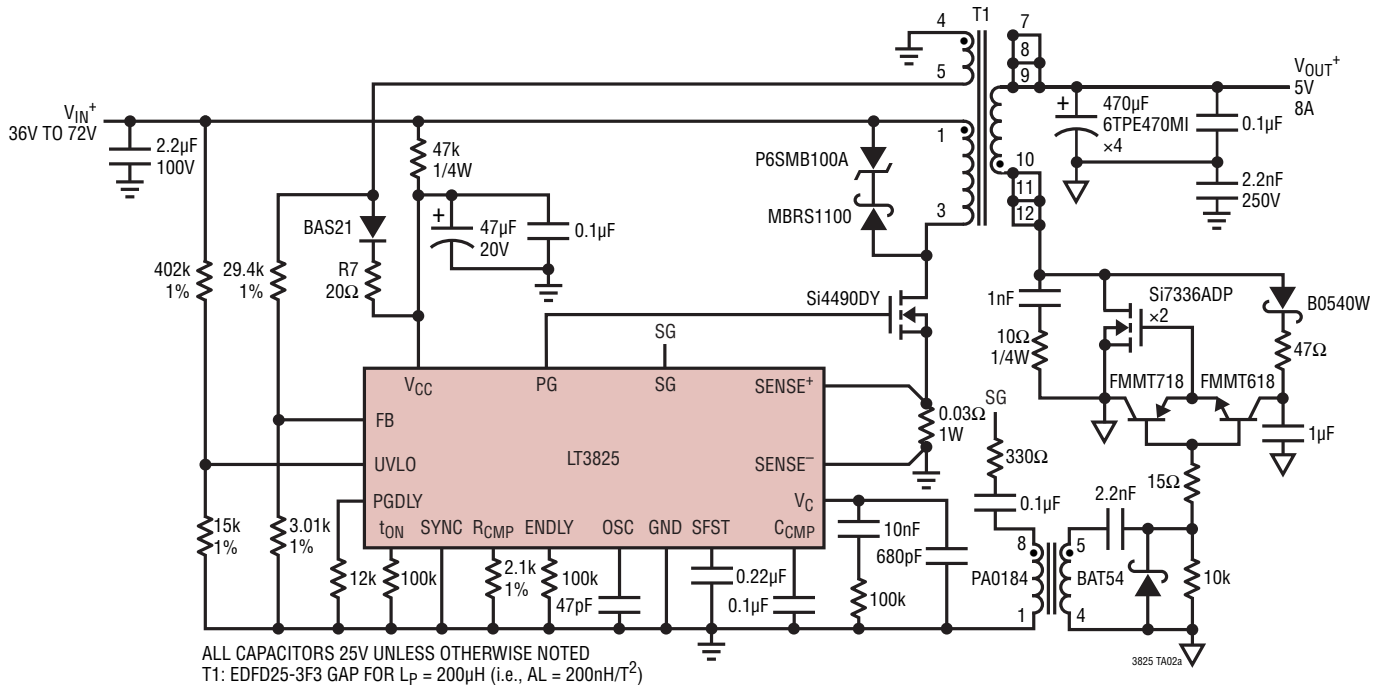

Figure 9. High Current Paths

TYPICAL APPLICATIONS

48V to 5V at 8A Isolated Supply



PINS 1 TO 3, 32T OF 2 × 32AWG  
 PINS 4 TO 5, 11T OF 1 × 32AWG  
 PINS 1 TO 3, 32T OF 2 × 32AWG  
 PINS 10, 11, 12 TO PINS 7, 8, 9, 4T OF 5 MIL COPPER FOIL  
 PINS 1 TO 3, 32T OF 2 × 32AWG

Efficiency vs Load Current

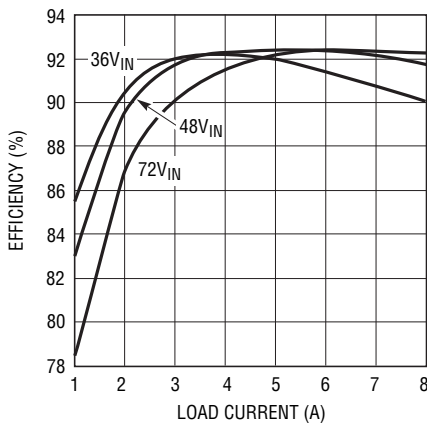

3825 TA02b

Output Regulation vs Load Current

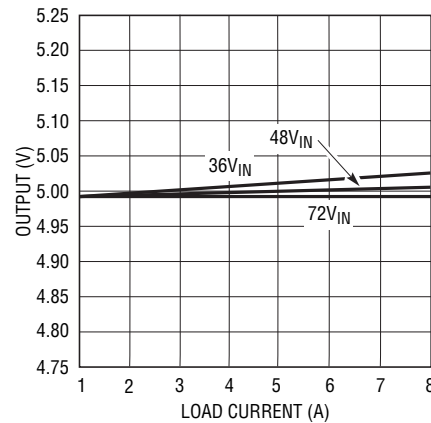

3825 TA02c

## TYPICAL APPLICATIONS

### 48V to 3.3V at 6A Isolated Supply

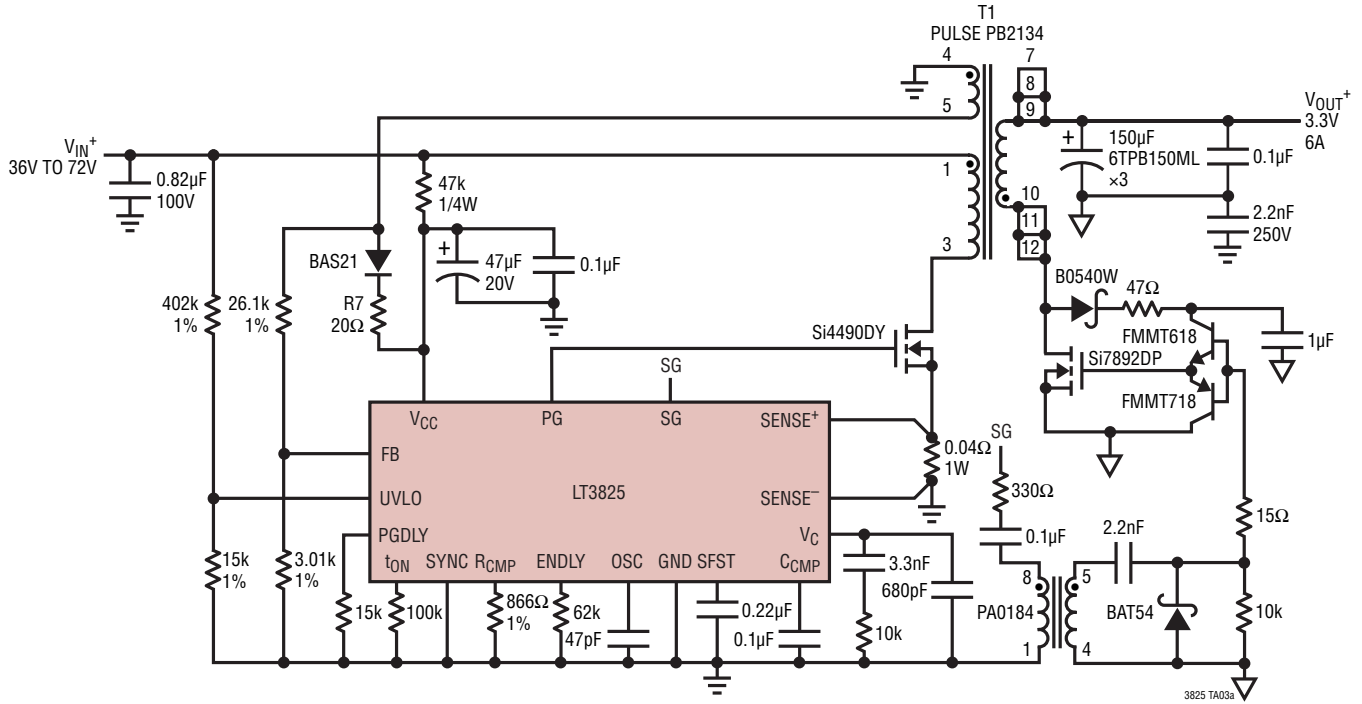

Efficiency vs Load Current

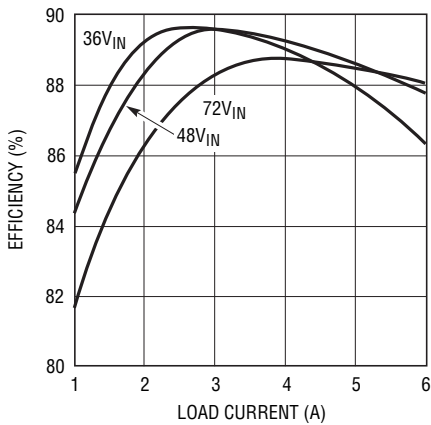

3825 TA03b

Output Regulation vs Load Current

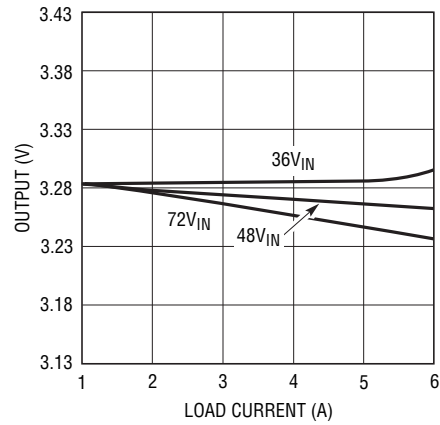

3825 TA03c

# TYPICAL APPLICATIONS

## 48V to 3.3V at 12A Isolated Supply

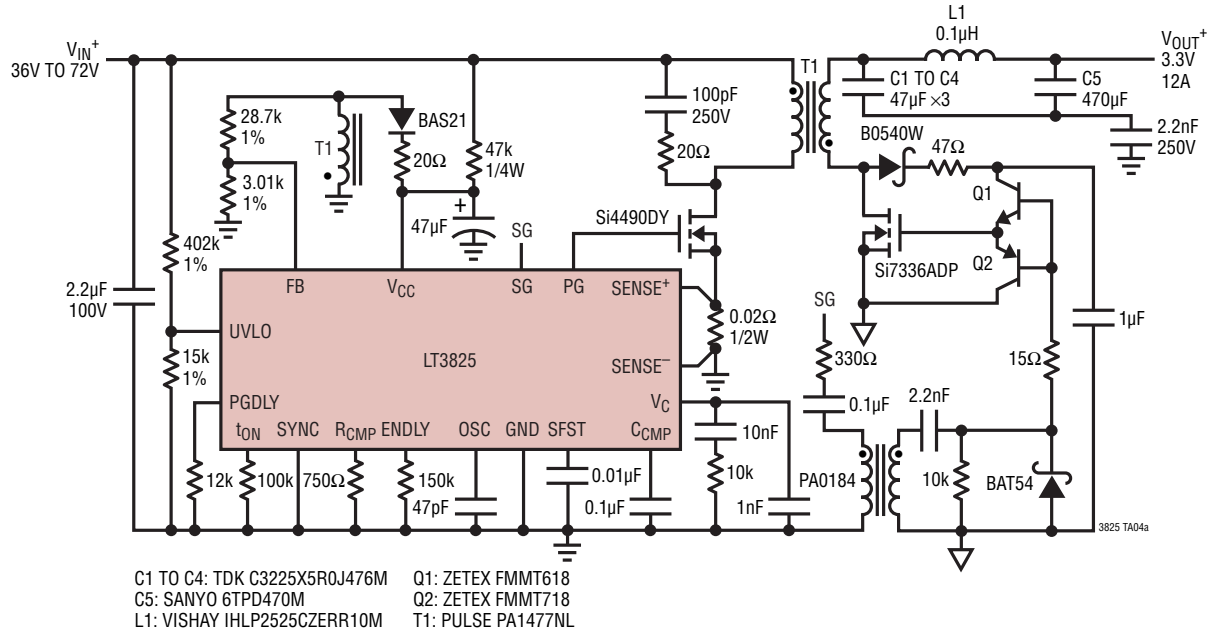

Efficiency vs Load Current

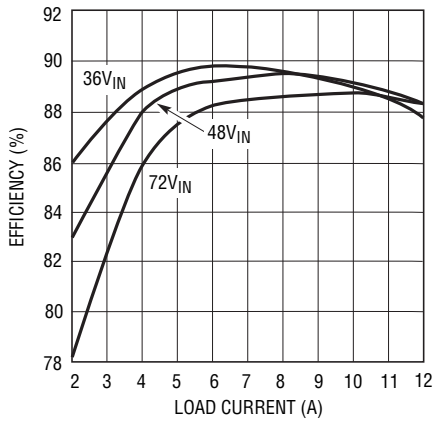

3825 TA04b

Output Regulation vs Load Current

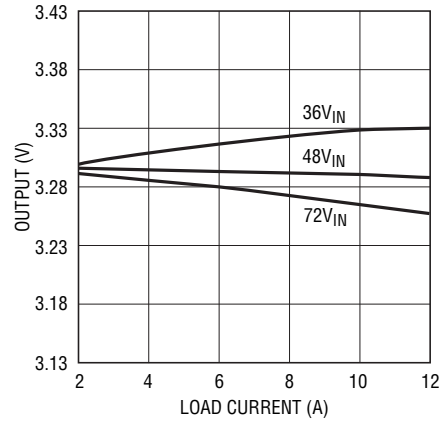

3825 TA04c

## PACKAGE DESCRIPTION

Please refer to <http://www.linear.com/designtools/packaging/> for the most recent package drawings.

**FE Package**  
**16-Lead Plastic TSSOP (4.4mm)**  
 (Reference LTC DWG # 05-08-1663 Rev J)  
**Exposed Pad Variation BC**

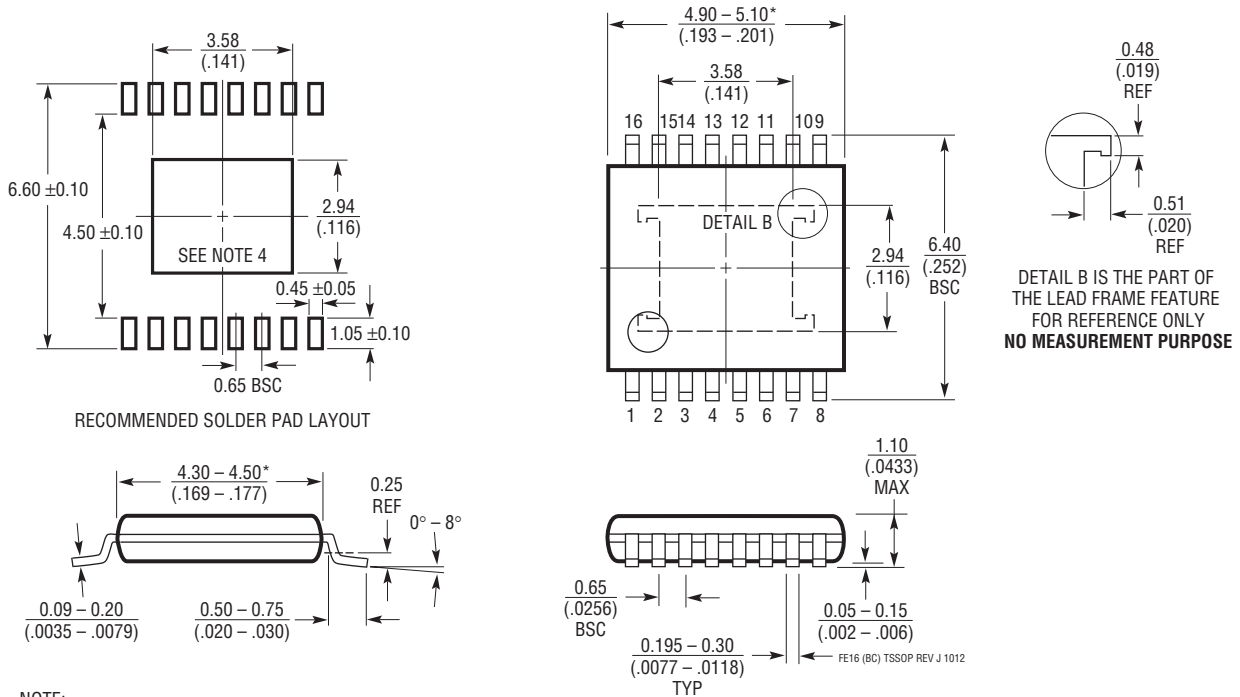

- NOTE:
1. CONTROLLING DIMENSION: MILLIMETERS
  2. DIMENSIONS ARE IN  $\frac{\text{MILLIMETERS}}{\text{INCHES}}$
  3. DRAWING NOT TO SCALE
  4. RECOMMENDED MINIMUM PCB METAL SIZE FOR EXPOSED PAD ATTACHMENT
- \*DIMENSIONS DO NOT INCLUDE MOLD FLASH. MOLD FLASH SHALL NOT EXCEED 0.150mm (.006") PER SIDE

DETAIL B IS THE PART OF THE LEAD FRAME FEATURE FOR REFERENCE ONLY  
**NO MEASUREMENT PURPOSE**

**REVISION HISTORY** (Revision history begins at Rev B)

REV	DATE	DESCRIPTION	PAGE NUMBER
B	12/09	Change to Absolute Maximum Ratings	2
		Change to Electrical Characteristics	2, 3
		Change to Pin Functions	6
		Change to Block Diagram	8
		Change to Flyback Feedback Amplifier	9
		Text Change to Applications Information	23
		Change to Typical Application	30
		Change to Related Parts	32
C	01/10	Change $T_A = 25^\circ\text{C}$ to $T_J = 25^\circ\text{C}$	2, 3
		Addition to Note 3	3
D	11/12	Changed Typical Application schematic's circuit rating	1
		Temperature grade clarification in Note 3	3
E	12/12	Updated G21 graph	6
		Updated package	30

## RELATED PARTS

PART NUMBER	DESCRIPTION	COMMENTS
LT3748	100V Isolated Flyback Controller	$5V \leq V_{IN} \leq 100V$ , No Opto Flyback, MSOP-16 with High Voltage Spacing
LT3758	Boost, Flyback, SEPIC and Inverting Controller	$5.5V \leq V_{IN} \leq 100V$ , Current Mode Control, 100kHz to 1MHz Programmable Operation Frequency, 3mm × 3mm DFN-10 and MSOP-10E Packages
LT3958	80V Flyback/Boost Converters	Monolithic with Integrated 3.3A Switch
LT3837	Isolated No Opto Synchronous Flyback Controller	Ideal for $V_{IN}$ from 4.5V to 36V, Limited by External Components, Up to 60W, Current Mode Control
LT3798	Off-Line, Isolated, No Opto-Coupler, Flyback Controller with Active PFC	$V_{IN}$ and $V_{OUT}$ Limited Only by External Components
LT3799	Off-Line, Isolated, Flyback LED Controller with Active PFC	$V_{IN}$ and $V_{OUT}$ Limited Only by External Components
LTC®3803/LTC3803-3/ LTC3803-5	200kHz Flyback DC/DC Controller	$V_{IN}$ and $V_{OUT}$ Limited Only by External Components, SOT-23 Package
LTC3873/LTC3873-5	No $R_{SENSE}^{\text{TM}}$ , Constant-Frequency, Flyback, Boost, SEPIC Controller	$V_{IN}$ and $V_{OUT}$ Limited Only by External Components, ThinSOT™ or DFN Packages
LTC3805/LTC3805-5	Adjustable, Fixed 70kHz to 700kHz Operating Frequency Flyback Controller	$V_{IN}$ and $V_{OUT}$ Limited Only by External Components, 3mm × 3mm DFN-10 and MSOP-10E Packages