

Dual Full Function White LED Step-Up Converter with Built-In Schottky Diodes

FEATURES

- Drives Up to 20 White LEDs (10 in Series per Converter) from a 3.6V Supply
- Two Independent Step-Up Converters Capable of Driving Asymmetric LED Strings
- Independent Dimming and Shutdown Control of the Two LED Strings
- Internal Schottky Diodes
- Internal Soft-Start Eliminates Inrush Current
- Open LED Protection (39.5V Max V_{OUT})
- Fixed Frequency Operation Up to 2MHz
- 81% Efficiency Driving 16 White LEDs at 15mA (Eight per Driver) from a 3.6V Supply
- Wide Input Voltage Range: 2.7V to 24V
- Available in 10-Pin DFN and 16-Pin Thermally Enhanced TSSOP Packages

APPLICATIONS

- Main/Sub Displays
- Digital Cameras, Sub-Notebook PCs
- PDAs, Handheld Computers
- Automotive

DESCRIPTION

LT[®]3466 is a dual full function step-up DC/DC converter specifically designed to drive up to 20 White LEDs (10 in series per converter) with a constant current. Series connection of the LEDs provides identical LED currents resulting in uniform brightness and eliminating the need for ballast resistors and expensive factory calibration.

The two independent converters are capable of driving asymmetric LED strings. The dimming of the two LED strings can also be controlled independently. The LT3466 is ideal for providing backlight for main and sub-displays in cell phones and other handheld devices.

The LT3466 operating frequency can be set with an external resistor over a 200kHz to 2MHz range. A low 200mV feedback voltage minimizes power loss in the current setting resistor for better efficiency. Additional features include output voltage limiting when LEDs are disconnected and internal soft-start.

The LT3466 is available in the 10-pin (3mm × 3mm × 0.75mm) DFN and 16-pin thermally enhanced TSSOP packages.

LT, LTC and LT are registered trademarks of Linear Technology Corporation.

TYPICAL APPLICATION

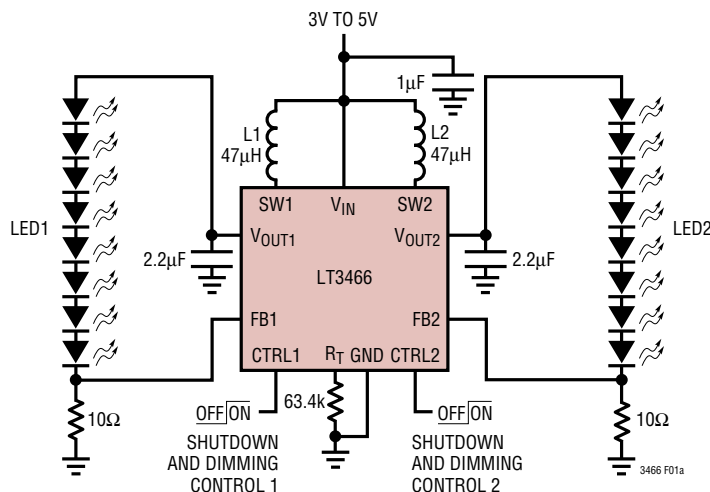
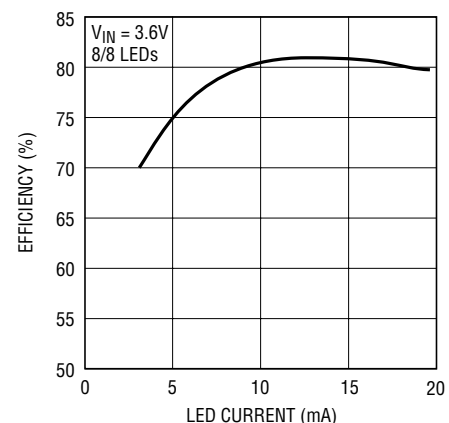

Figure 1. Li-Ion Powered Driver for 8/8 White LEDs

Conversion Efficiency



3466 F01b

ABSOLUTE MAXIMUM RATINGS (Note 1)

Input Voltage (V_{IN})	24V	Maximum Junction Temperature	125°C
SW1, SW2 Voltages	44V	Storage Temperature Range	
V_{OUT1} , V_{OUT2} Voltages	44V	DFN	-65°C to 125°C
CTRL1, CTRL2 Voltages	24V	TSSOP	-65°C to 150°C
FB1, FB2, R_T Voltages	2V	Lead Temperature (Soldering, 10 sec, TSSOP)	300°C
Operating Temperature Range (Note 2) ...	-40°C to 85°C		

PACKAGE/ORDER INFORMATION

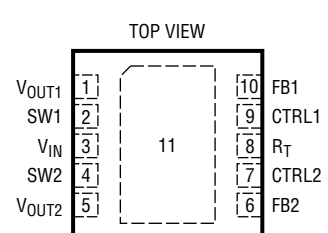
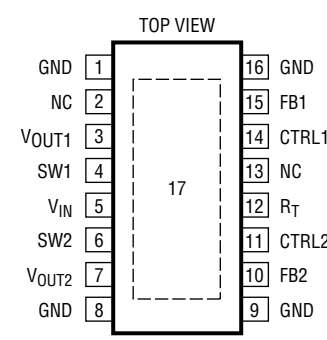
 <p>DD PACKAGE 10-LEAD (3mm × 3mm) PLASTIC DFN $T_{JMAX} = 125^{\circ}\text{C}$, $\theta_{JA} = 43^{\circ}\text{C/W}$, $\theta_{JC} = 2.96^{\circ}\text{C/W}$ EXPOSED PAD (PIN 11) IS GND MUST BE SOLDERED TO PCB</p>	ORDER PART NUMBER	 <p>FE PACKAGE 16-LEAD PLASTIC TSSOP $T_{JMAX} = 125^{\circ}\text{C}$, $\theta_{JA} = 38^{\circ}\text{C/W}$, $\theta_{JC(PAD)} = 10^{\circ}\text{C/W}$ EXPOSED PAD (PIN 17) IS GND MUST BE SOLDERED TO PCB</p>	ORDER PART NUMBER
	LT3466EDD		LT3466EFE
	DD PART MARKING		FE PART MARKING
LBBH	3466EFE		

Consult LTC Marketing for parts specified with wider operating temperature ranges.

ELECTRICAL CHARACTERISTICS

The ● denotes specifications that apply over the full operating temperature range, otherwise specifications are at $T_A = 25^{\circ}\text{C}$. $V_{IN} = 3\text{V}$, $V_{CTRL1} = 3\text{V}$, $V_{CTRL2} = 3\text{V}$, unless otherwise specified.

PARAMETER	CONDITIONS	MIN	TYP	MAX	UNITS
Minimum Operating Voltage		2.7			V
Maximum Operating Voltage				24	V
FB1 Voltage		● 192	200	208	mV
FB2 Voltage		● 192	200	208	mV
Offset Voltage (V_{OS}) Between FB1 and FB2 Voltages	$V_{OS} = \text{FB1} - \text{FB2} $	0	1.5	7.5	mV
FB1 Pin Bias Current	$V_{FB1} = 0.2\text{V}$ (Note 3)		10	50	nA
FB2 Pin Bias Current	$V_{FB2} = 0.2\text{V}$ (Note 3)		10	50	nA
Quiescent Current	$V_{FB1} = V_{FB2} = 0.3\text{V}$ $CTRL1 = CTRL2 = 0\text{V}$		5	7.5	mA
			16	25	μA
Switching Frequency	$R_T = 48.7\text{k}$	0.8	1	1.2	MHz
Oscillator Frequency Range	(Note 4)	200		2000	kHz
Nominal R_T Pin Voltage	$R_T = 48.7\text{k}$		0.54		V
Maximum Duty Cycle	$R_T = 48.7\text{k}$ $R_T = 20.5\text{k}$ $R_T = 267\text{k}$	● 90	96		%
			92		%
			99		%

ELECTRICAL CHARACTERISTICS The ● denotes specifications that apply over the full operating temperature range, otherwise specifications are at $T_A = 25^\circ\text{C}$. $V_{IN} = 3\text{V}$, $V_{CTRL1} = 3\text{V}$, $V_{CTRL2} = 3\text{V}$, unless otherwise specified.

PARAMETER	CONDITIONS		MIN	TYP	MAX	UNITS
Converter 1 Current Limit	(Note 5)	●	320	400		mA
Converter 2 Current Limit	(Note 5)	●	320	400		mA
Converter 1 V_{CESAT}	$I_{SW1} = 300\text{mA}$			360		mV
Converter 2 V_{CESAT}	$I_{SW2} = 300\text{mA}$			360		mV
Switch 1 Leakage Current	$V_{SW1} = 10\text{V}$			0.01	5	μA
Switch 2 Leakage Current	$V_{SW2} = 10\text{V}$			0.01	5	μA
CTRL1 Voltage for Full LED Current		●	1.8			V
CTRL2 Voltage for Full LED Current		●	1.8			V
CTRL1 or CTRL2 Voltage to Turn-On the IC			150			mV
CTRL1 and CTRL2 Voltages to Shut Down the IC					50	mV
CTRL1, CTRL2 Pin Bias Current	$V_{CTRL1} = V_{CTRL2} = 1\text{V}$	●	8	10	12	μA
V_{OUT1} Overvoltage-Lockout Threshold	V_{OUT1} Rising			39.5		V
V_{OUT2} Overvoltage-Lockout Threshold	V_{OUT2} Rising			39.5		V
Schottky 1 Forward Drop	$I_{SCHOTTKY1} = 300\text{mA}$			0.85		V
Schottky 2 Forward Drop	$I_{SCHOTTKY2} = 300\text{mA}$			0.85		V
Schottky 1 Reverse Leakage	$V_{OUT1} = 20\text{V}$				5	μA
Schottky 2 Reverse Leakage	$V_{OUT2} = 20\text{V}$				5	μA
Soft-Start Time (Switcher 1)				600		μs
Soft-Start Time (Switcher 2)				600		μs

Note 1: Absolute Maximum Ratings are those values beyond which the life of a device may be impaired.

Note 2: The LT3466E is guaranteed to meet specified performance from 0°C to 70°C . Specifications over the -40°C to 85°C operating range are assured by design, characterization and correlation with statistical process controls.

Note 3: Current flows out of the pin.

Note 4: Guaranteed by design and test correlation, not production tested.

Note 5: Current limit is guaranteed by design and/or correlation to static test. Slope compensation reduces current limit at high duty cycle.

TYPICAL PERFORMANCE CHARACTERISTICS

Switching Waveforms

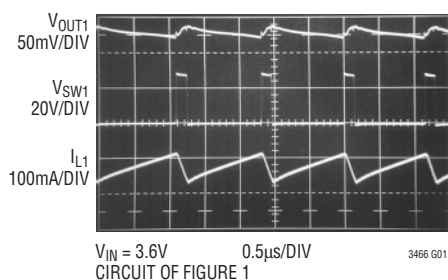

Transient Response

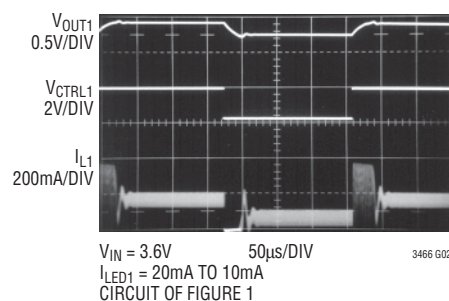

TYPICAL PERFORMANCE CHARACTERISTICS

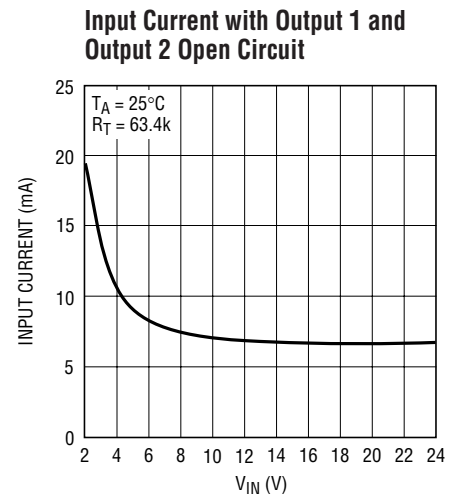
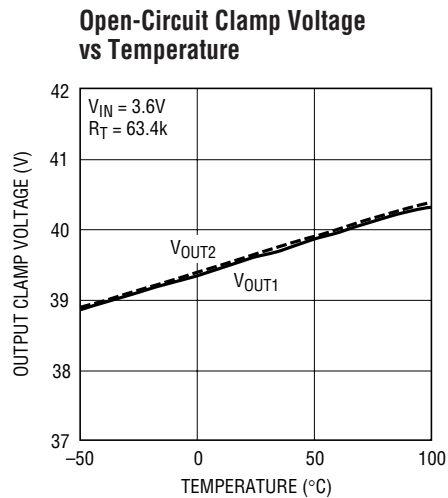
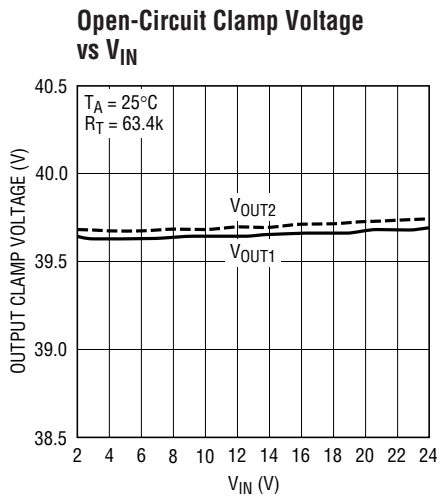
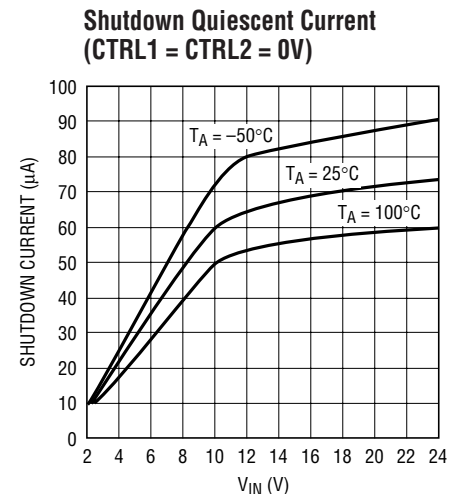
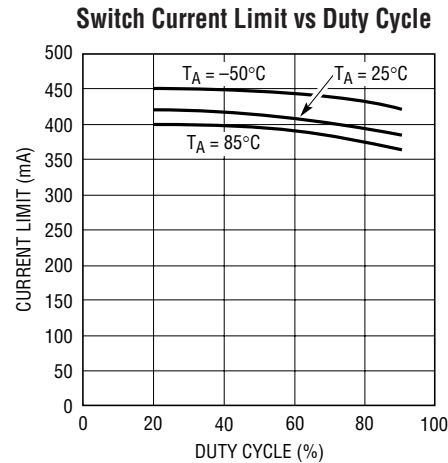
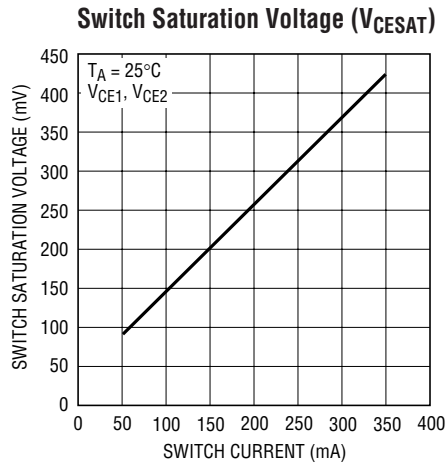
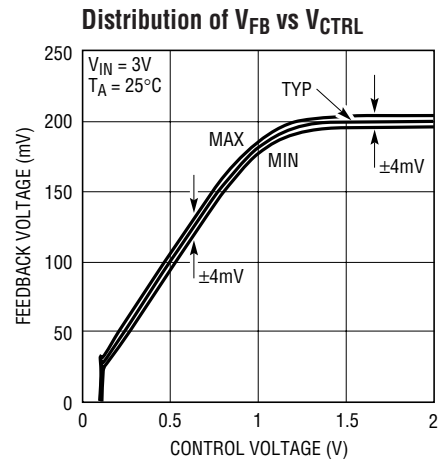
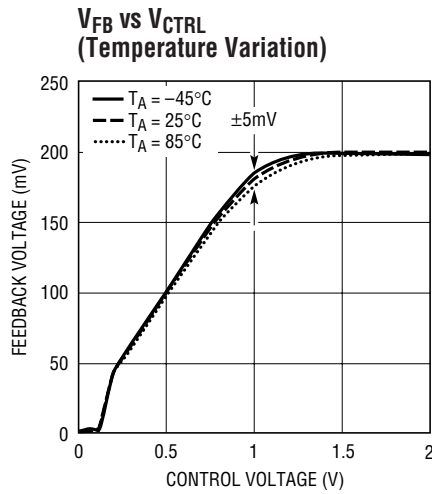
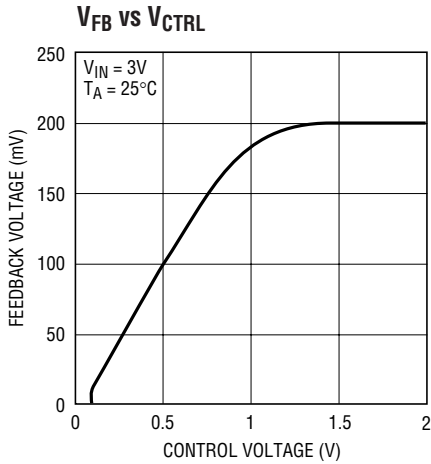

TYPICAL PERFORMANCE CHARACTERISTICS

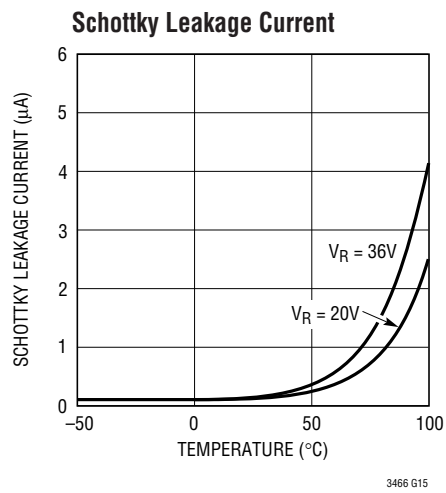
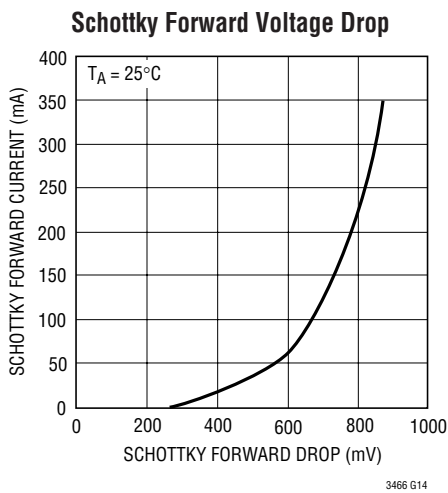
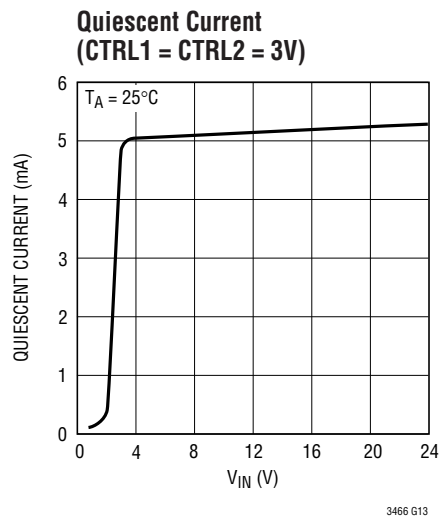
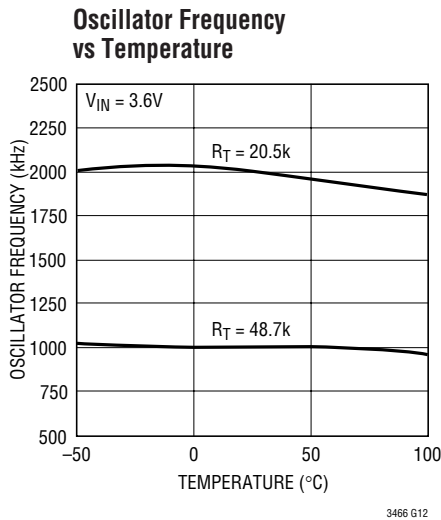
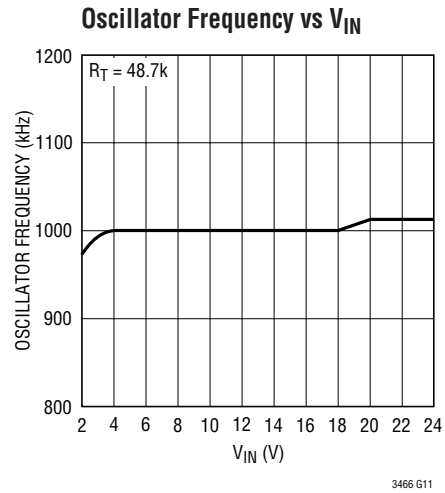
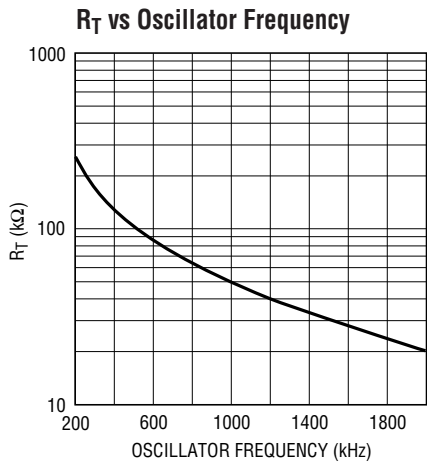

PIN FUNCTIONS (DD/TSSOP)

V_{OUT1} (Pin 1/Pin 3): Output of Converter 1. This pin is connected to the cathode of the internal Schottky diode. Connect an output capacitor from this pin to ground.

SW1 (Pin 2/Pin 4): Switch Pin for Converter 1. Connect the inductor at this pin.

V_{IN} (Pin 3/Pin 5): Input Supply Pin. Must be locally bypassed with a 1μF, X5R or X7R type ceramic capacitor.

SW2 (Pin 4/Pin 6): Switch Pin for Converter 2. Connect the inductor at this pin.

V_{OUT2} (Pin 5/Pin 7): Output of Converter 2. This pin is connected to the cathode of the internal Schottky diode. Connect an output capacitor from this pin to ground.

FB2 (Pin 6/Pin 10): Feedback Pin for Converter 2. The nominal voltage at this pin is 200mV. Connect cathode of the lowest LED and the feedback resistor at this pin. The LED current can be programmed by :

$$I_{LED2} \approx (200\text{mV}/R_{FB2}), \text{ when } V_{CTRL2} > 1.6\text{V}$$

$$I_{LED2} \approx (V_{CTRL2}/5 \cdot R_{FB2}), \text{ when } V_{CTRL2} < 1\text{V}$$

CTRL2 (Pin 7/Pin 11): Dimming and Shutdown Pin for Converter 2. Connect this pin to ground to disable the converter. As the pin voltage is ramped from 0V to 1.6V, the LED current ramps from 0 to I_{LED2} ($= 200\text{mV}/R_{FB2}$). Any voltage above 1.6V does not affect the LED current.

R_T (Pin 8/Pin 12): Timing Resistor to Program the Switching Frequency. The switching frequency can be programmed from 200KHz to 2MHz.

CTRL1 (Pin 9/Pin 14): Dimming and Shutdown Pin for Converter 1. Connect this pin to ground to disable the converter. As the pin voltage is ramped from 0V to 1.6V, the LED current ramps from 0 to I_{LED1} ($= 200\text{mV}/R_{FB1}$). Any voltage above 1.6V does not affect the LED current.

FB1 (Pin 10/Pin 15): Feedback Pin for Converter 1. The nominal voltage at this pin is 200mV. Connect cathode of the lowest LED and the feedback resistor at this pin. The LED current can be programmed by :

$$I_{LED1} \approx (200\text{mV}/R_{FB1}), \text{ when } V_{CTRL1} > 1.6\text{V}$$

$$I_{LED1} \approx (V_{CTRL1}/5 \cdot R_{FB1}), \text{ when } V_{CTRL1} < 1\text{V}$$

Exposed Pad (Pin 11/Pin 17): The Exposed Pad must be soldered to the PCB system ground.

GND (NA/Pins 1, 8, 9, 16): These pins are internally fused to the Exposed Pad (TSSOP package only). Connect these GND pins and the Exposed Pad to the PCB system ground.

BLOCK DIAGRAM

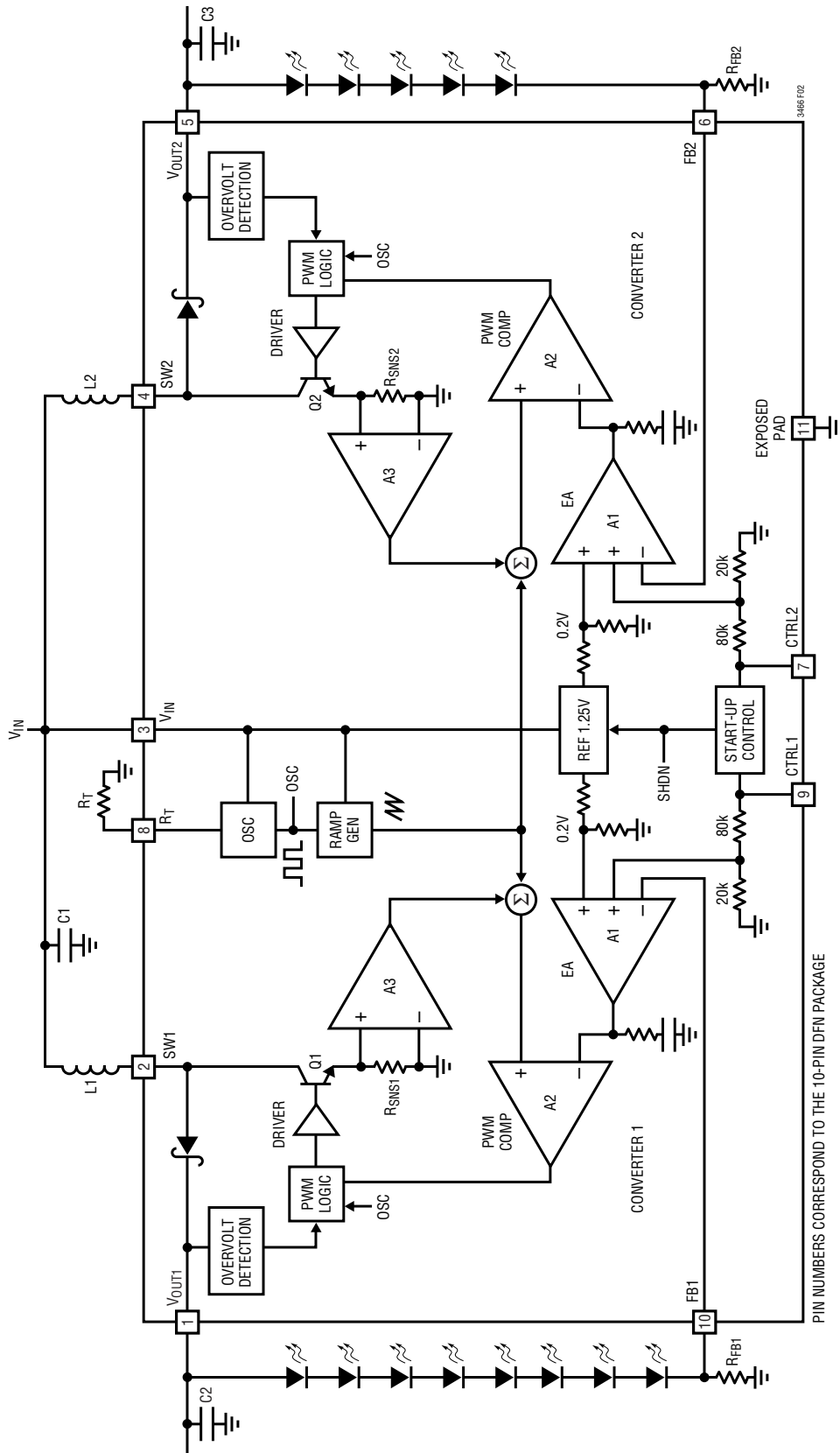

Figure 2. LT3466 Block Diagram

PIN NUMBERS CORRESPOND TO THE 10-PIN DFN PACKAGE

OPERATION

Main Control Loop

The LT3466 uses a constant frequency, current mode control scheme to provide excellent line and load regulation. It incorporates two identical, but fully independent PWM converters. Operation can be best understood by referring to the Block Diagram in Figure 2. The oscillator, start-up bias and the bandgap reference are shared between the two converters. The control circuitry, power switch, Schottky diode etc., are all identical for both the converters.

At power-up, the output voltages V_{OUT1} and V_{OUT2} are charged up to V_{IN} (input supply voltage) via their respective inductor and the internal Schottky diode. If either CTRL1 and CTRL2 or both are pulled high, the bandgap reference, start-up bias and the oscillator are turned on.

Working of the main control loop can be understood by following the operation of converter 1. At the start of each oscillator cycle, the power switch Q1 is turned on. A voltage proportional to the switch current is added to a stabilizing ramp and the resulting sum is fed into the positive terminal of the PWM comparator A2. When this voltage exceeds the level at the negative input of A2, the PWM logic turns off the power switch. The level at the negative input of A2 is set by the error amplifier A1, and is simply an amplified version of the difference between the feedback voltage and the 200mV reference voltage. In this manner, the error amplifier A1 regulates the feedback voltage to 200mV reference voltage. The output of the error amplifier A1 sets the correct peak current level in inductor L1 to keep the output in regulation. The CTRL1 pin voltage is used to adjust the reference voltage.

If only one of the converters is turned on, the other converter will stay off and its output will remain charged up to V_{IN} (input supply voltage). The LT3466 enters into shutdown, when both CTRL1 and CTRL2 are pulled lower than 50mV. The CTRL1 and CTRL2 pins perform independent dimming and shutdown control for the two converters.

Minimum Output Current

The LT3466 can drive an 8-LED string at 2.5mA LED current without pulse skipping. As current is further reduced, the device may begin skipping pulses. This will

result in some low frequency ripple, although the LED current remains regulated on an average basis down to zero. The photo in Figure 3 shows circuit operation with 16 white LEDs (eight per converter) at 2.5mA current driven from 3.6V supply. Peak inductor current is less than 50mA and the regulator operates in discontinuous mode implying that the inductor current reached zero during the discharge phase. After the inductor current reaches zero, the switch pin exhibits ringing due to the LC tank circuit formed by the inductor in combination with switch and diode capacitance. This ringing is not harmful; far less spectral energy is contained in the ringing than in the switch transitions. The ringing can be damped by application of a 300Ω resistor across the inductors, although this will degrade efficiency.

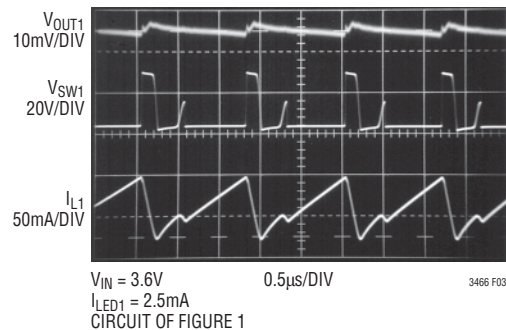

Figure 3. Switching Waveforms

Open-Circuit Protection

The LT3466 has internal open-circuit protection for both the converters. When the LEDs are disconnected from the circuit or fail open, the converter output voltage is clamped at 39.5V (typ). Figure 4a shows the transient response of Figure 1's step-up converter with LED1 disconnected. With LED1 disconnected, the converter starts switching at the peak inductor current limit. The converter output starts ramping up and finally gets clamped at 39.5V (typ). The converter will then switch at low inductor current to regulate the converter output at the clamp voltage. Output voltage and input current during output open circuit are shown in the Typical Performance Characteristics graphs.

In the event one of the converters has an output open-circuit, its output voltage will be clamped at 39.5V.

OPERATION

However, the other converter will continue functioning properly. The photo in Figure 4b shows circuit operation with converter 1 output open-circuit and converter 2 driving eight LEDs at 20mA. Converter 1 starts switching at a lower peak inductor current and begins skipping pulses, thereby reducing its input current.

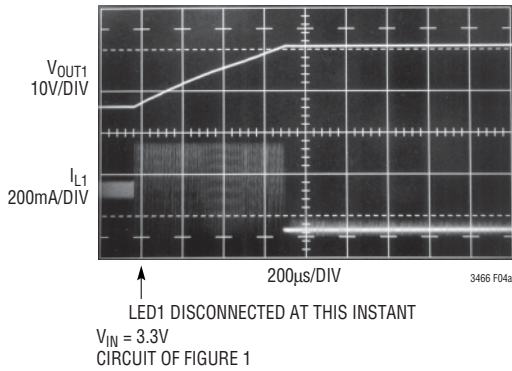

Figure 4a. Transient Response of Switcher 1 with LED1 Disconnected from the Output

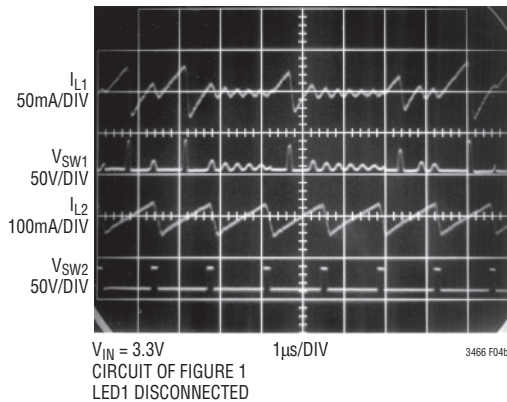

Figure 4b. Switching Waveforms with Output 1 Open-Circuit

Soft-Start

The LT3466 has a separate internal soft-start circuitry for each converter. Soft-start helps to limit the inrush current during start-up. Soft-start is achieved by clamping the output of the error amplifier during the soft-start period. This limits the peak inductor current and ramps up the output voltage in a controlled manner.

The converter enters into soft-start mode whenever the respective CTRL pin is pulled from low to high. Figure 5 shows the start-up waveforms with converter 1 driving four LEDs at 20mA. The filtered input current, as shown in Figure 5, is well controlled. The soft-start circuit is less effective when driving a higher number of LEDs.

Undervoltage Lockout

The LT3466 has an undervoltage lockout circuit which shuts down both the converters when the input voltage drops below 2.1V (typ). This prevents the converter from operating in an erratic mode when powered from low supply voltages.

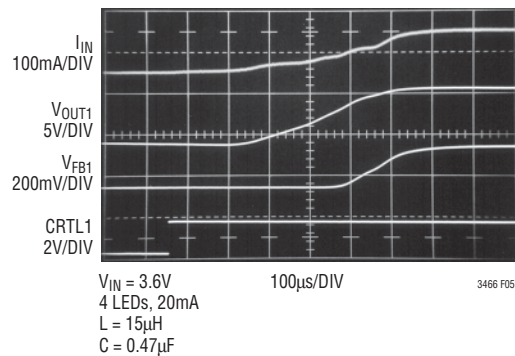

Figure 5. Start-Up Waveforms

APPLICATIONS INFORMATION

DUTY CYCLE

The duty cycle for a step-up converter is given by:

$$D = \frac{V_{OUT} + V_D - V_{IN}}{V_{OUT} + V_D - V_{CESAT}}$$

where:

V_{OUT} = Output voltage

V_D = Schottky forward voltage drop

V_{CESAT} = Saturation voltage of the switch

V_{IN} = Input battery voltage

The maximum duty cycle achievable for LT3466 is 96% (typ) when running at 1MHz switching frequency. It increases to 99% (typ) when run at 200kHz and drops to 92% (typ) at 2MHz. Always ensure that the converter is not duty-cycle limited when powering the LEDs at a given switching frequency.

SETTING THE SWITCHING FREQUENCY

The LT3466 uses a constant frequency architecture that can be programmed over a 200kHz to 2MHz range with a single external timing resistor from the R_T pin to ground. The nominal voltage on the R_T pin is 0.54V, and the

current that flows into the timing resistor is used to charge and discharge an internal oscillator capacitor. A graph for selecting the value of R_T for a given operating frequency is shown in Figure 6.

OPERATING FREQUENCY SELECTION

The choice of operating frequency is determined by several factors. There is a tradeoff between efficiency and component size. Higher switching frequency allows the use of smaller inductors albeit at the cost of increased switching losses and decreased efficiency.

Another consideration is the maximum duty cycle achievable. In certain applications, the converter needs to operate at the maximum duty cycle in order to light up the maximum number of LEDs. The LT3466 has a fixed oscillator off-time and a variable on-time. As a result, the maximum duty cycle increases as the switching frequency is decreased.

The circuit of Figure 1 is operated with different values of timing resistor (R_T). R_T is chosen so as to run the converters at 800kHz ($R_T = 63.4k$), 1.25MHz ($R_T = 39.1k$) and 2MHz ($R_T = 20.5k$). The efficiency comparison for different R_T values is shown in Figure 7.

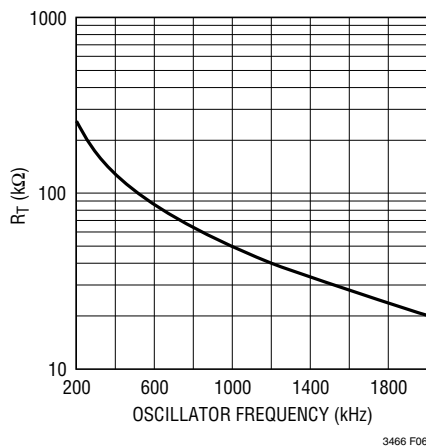

Figure 6. Timing Resistor (R_T) Value

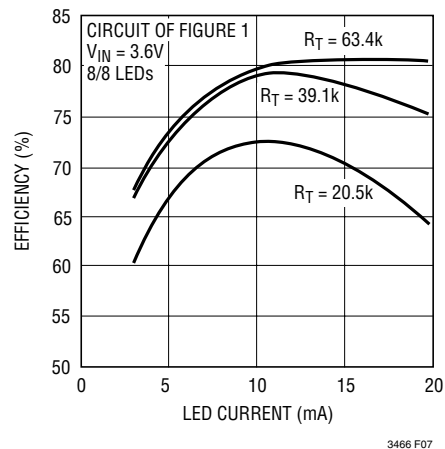

Figure 7. Efficiency Comparison for Different R_T Resistors

APPLICATIONS INFORMATION

INDUCTOR SELECTION

The choice of the inductor will depend on the selection of the switching frequency of the LT3466. The switching frequency can be programmed from 200kHz to 2MHz. Higher switching frequency allows the use of smaller inductors albeit at the cost of increased switching losses.

The inductor current ripple (ΔI_L), neglecting the drop across the Schottky diode and the switch, is given by :

$$\Delta I_L = \frac{V_{IN(MIN)} \cdot (V_{OUT(MAX)} - V_{IN(MIN)})}{V_{OUT(MAX)} \cdot f \cdot L}$$

where:

L = Inductor

f = Operating frequency

$V_{IN(MIN)}$ = Minimum input voltage

$V_{OUT(MAX)}$ = Maximum output voltage

The ΔI_L is typically set to 20% to 40% of the maximum inductor current.

The inductor should have a saturation current rating greater than the peak inductor current required for the application. Also, ensure that the inductor has a low DCR (copper wire resistance) to minimize I^2R power losses. Recommended inductor values range from 10 μ H to 68 μ H.

Several inductors that work well with the LT3466 are listed in Table 1. Consult each manufacturer for more detailed information and for their entire selection of related parts.

Table 1. Recommended Inductors

PART	L (μ H)	MAX DCR (Ω)	CURRENT RATING (mA)	VENDOR
LQH32CN100	10	0.44	300	Murata (814) 237-1431 www.murata.com
LQH32CN150	15	0.58	300	
LQH43CN330	33	1.00	310	
ELL6RH330M	33	0.38	600	Panasonic (714) 373-7939 www.panasonic.com
ELL6SH680M	68	0.52	500	
A914BYW330M	33	0.45	440	Toko www.toko.com
A914BYW470M	47	0.73	360	
A920CY680M	68	0.40	400	
CDRH2D18150NC	15	0.22	350	Sumida (847) 956-0666 www.sumida.com
CDRH4D18-330	33	0.51	310	
CDRH5D18-680	68	0.84	430	

CAPACITOR SELECTION

The small size of ceramic capacitors make them ideal for LT3466 applications. Use only X5R and X7R types because they retain their capacitance over wider voltage and temperature ranges than other types such as Y5V or Z5U. A 1 μ F input capacitor is sufficient for most applications. Always use a capacitor with sufficient voltage rating.

Table 2 shows a list of several ceramic capacitor manufacturers. Consult the manufacturers for detailed information on their entire selection of ceramic parts.

Table 2. Ceramic Capacitor Manufacturers

Taiyo Yuden	(408) 573-4150 www.t-yuden.com
AVX	(803) 448-9411 www.avxcorp.com
Murata	(714) 852-2001 www.murata.com

INRUSH CURRENT

The LT3466 has built-in Schottky diodes. When supply voltage is applied to the V_{IN} pin, an inrush current flows through the inductor and the Schottky diode and charges up the output voltage. Both the Schottky diodes in the LT3466 can sustain a maximum of 1A current. The selection of inductor and capacitor value should ensure the peak of the inrush current to be below 1A.

For low DCR inductors, which is usually the case for this application, the peak inrush current can be simplified as follows:

$$I_{PK} = \frac{V_{IN} - 0.6}{\omega L}$$

where:

$$\omega = \frac{1}{\sqrt{LC_{OUT}}}$$

Table 3 gives inrush peak current for some component selections.

APPLICATIONS INFORMATION

Table 3. Inrush Peak Current

V _{IN} (V)	L (μH)	C _{OUT} (μF)	I _P (A)
5	15	0.47	0.78
5	33	1.00	0.77
5	47	2.2	0.95
5	68	1.00	0.53
9	47	0.47	0.84
12	33	0.22	0.93

Typically peak inrush current will be less than the value calculated above. This is due to the fact that the DC resistance in the inductor provides some damping resulting in a lower peak inrush current.

PROGRAMMING LED CURRENT

The LED current of each LED string can be set independently by the choice of resistors R_{FB1} and R_{FB2} respectively (Figure 2). The feedback reference is 200mV. In order to have accurate LED current, precision resistors are preferred (1% is recommended).

$$R_{FB1} = \frac{200\text{mV}}{I_{LED1}}$$

$$R_{FB2} = \frac{200\text{mV}}{I_{LED2}}$$

Table 4. R_{FB} Value Selection

I _{LED} (mA)	R _{FB} (Ω)
5	40.2
10	20.0
15	13.3
20	10.0
25	8.06

Most White LEDs are driven at maximum currents of 15mA to 20mA.

DIMMING CONTROL

There are two different types of dimming control circuits. The LED current in the two drivers can be set independently by modulating the CTRL1 and CTRL2 pins respectively.

Using a DC Voltage

For some applications, the preferred method of brightness control is a variable DC voltage to adjust the LED current. The CTRL pin voltage can be modulated to set the dimming of the respective LED string. As the voltage on the CTRL pin increases from 0V to 1.6V, the LED current increases from 0 to I_{LED}. As the CTRL pin voltage increases beyond 1.6V, it has no effect on the LED current.

The LED current can be set by:

$$I_{LED} \approx (200\text{mV}/R_{FB}), \text{ when } V_{CTRL} > 1.6\text{V}$$

$$I_{LED} \approx (V_{CTRL}/5 \cdot R_{FB}), \text{ when } V_{CTRL} < 1\text{V}$$

Feedback voltage variation versus control voltage is given in the Typical Performance Characteristics graphs.

Using a Filtered PWM Signal

A variable duty cycle PWM can be used to control the brightness of the LED string. The PWM signal is filtered (Figure 8) by an RC network and fed to the CTRL1, CTRL2 pins.

The corner frequency of R1, C1 should be much lower than the frequency of the PWM signal. R1 needs to be much smaller than the internal impedance in the CTRL pins, which is 100kΩ.

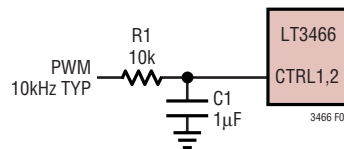

Figure 8. Dimming Control Using a Filtered PWM Signal

LOW INPUT VOLTAGE APPLICATIONS

The LT3466 can be used in low input voltage applications. The input supply voltage to the LT3466 must be 2.7V or higher. However, the inductors can be run off a lower battery voltage. This technique allows the LEDs to be powered off two alkaline cells. Most portable devices have a 3.3V logic supply voltage which can be used to power the LT3466. The LEDs can be driven straight from the battery, resulting in higher efficiency.

APPLICATIONS INFORMATION

Figure 9 shows four LEDs being powered off two AA cells. The battery is connected to the inductors and the chip is powered off 3.3V logic supply voltage.

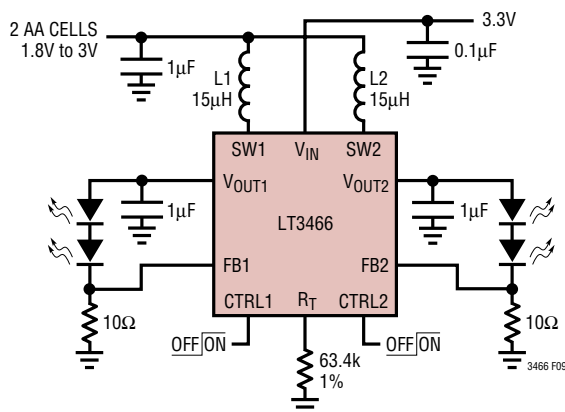

Figure 9. 2 AA Cells to Four White LEDs

HIGH INPUT VOLTAGE APPLICATIONS

The input voltage to the LT3466 can be as high as 24V. This gives it the flexibility of driving a large number of LEDs when being powered off a higher voltage. The maximum number of LEDs that can be driven is constrained by the converter output voltages being clamped at 39.5V (typ).

The LT3466 can be used to drive 20 White LEDs (10 per converter) at 20mA when powered off two Li-Ion cells in series.

BOARD LAYOUT CONSIDERATION

As with all switching regulators, careful attention must be paid to the PCB board layout and component placement. To prevent electromagnetic interference (EMI) problems, proper layout of high frequency switching paths is essential. Minimize the length and area of all traces connected to the switching node pins (SW1 and SW2). Keep the feedback pins (FB1 and FB2) away from the switching nodes.

The exposed paddle for both DFN and TSSOP packages must be connected to the system ground. The ground connection for the feedback resistors should be tied directly to the ground plane and not shared with any other component, except the R_T resistor, ensuring a clean, noise-free connection. Recommended component placement for the DFN package is shown in Figure 10.

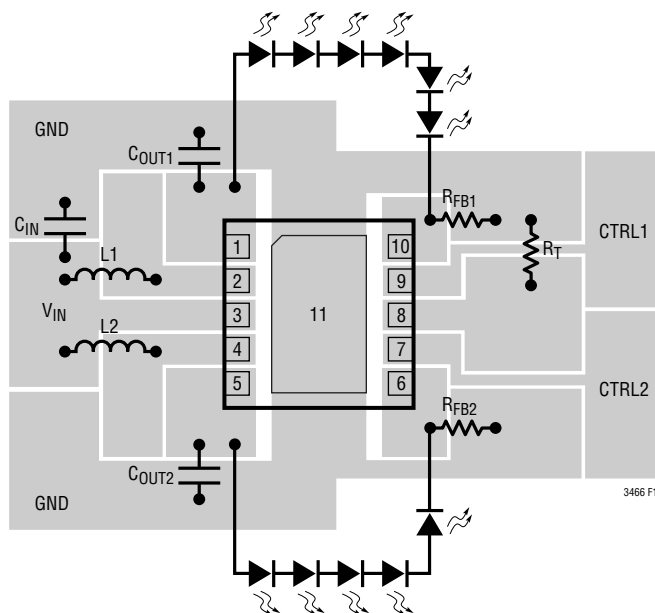
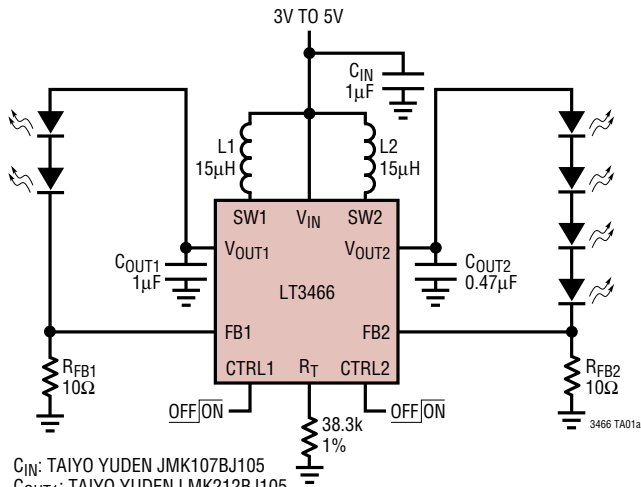

Figure 10. Recommended Component Placement (DFN Package)

TYPICAL APPLICATIONS

Li-Ion to 2/4 White LEDs



C_{IN} : TAIYO YUDEN JMK107BJ105
 C_{OUT1} : TAIYO YUDEN LMK212BJ105
 C_{OUT2} : TAIYO YUDEN EMK212BJ474
 $L1, L2$: MURATA LQH32CN150

Conversion Efficiency

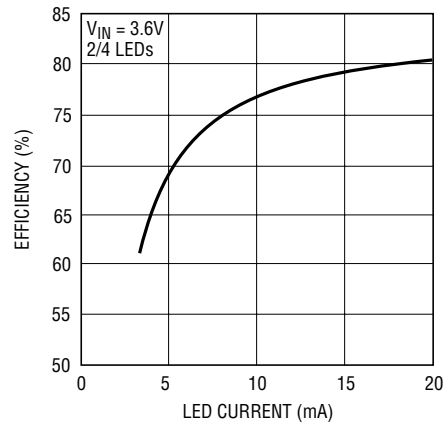

3466 TA01b

Li-Ion to 5/5 White LEDs

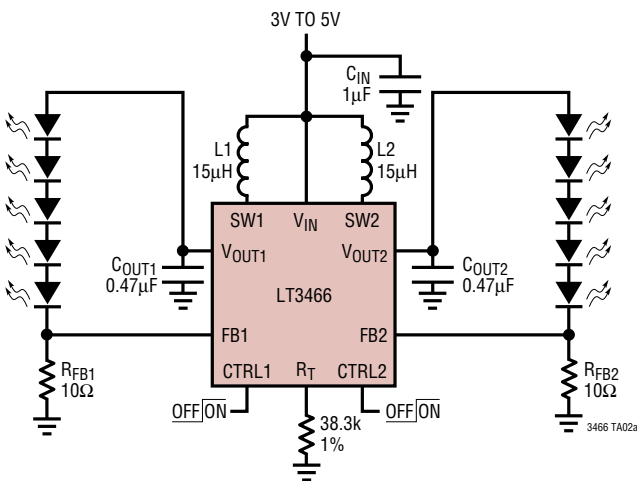

C_{IN} : TAIYO YUDEN JMK107BJ105
 C_{OUT1}, C_{OUT2} : TAIYO YUDEN GMK212BJ474
 $L1, L2$: MURATA LQH32CN150

Conversion Efficiency

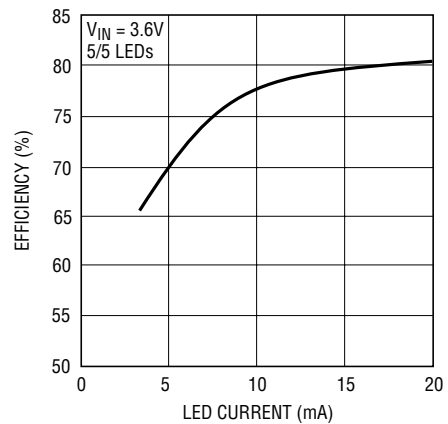

3466 TA02b

TYPICAL APPLICATIONS

Li-Ion to 6/6 White LEDs

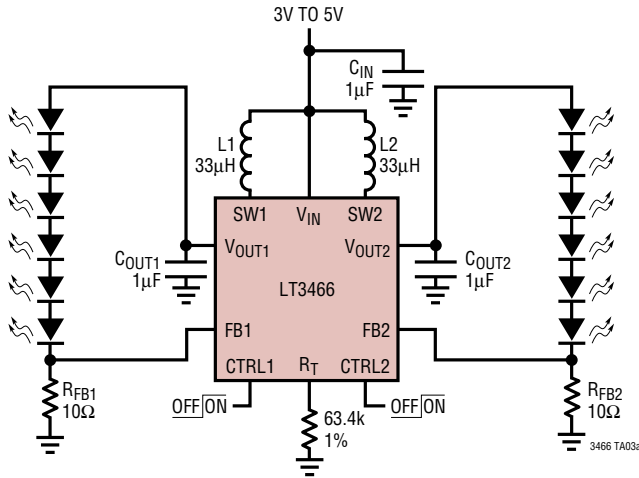

C_{IN}: TAIYO YUDEN JMK107BJ105
 C_{OUT1}, C_{OUT2}: TAIYO YUDEN GMK316BJ105
 L1, L2: TOKO A914BYW-330M

Conversion Efficiency

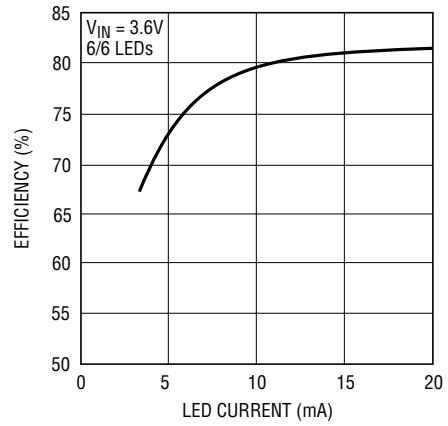

3466 TA03b

Li-Ion to 7/7 White LEDs

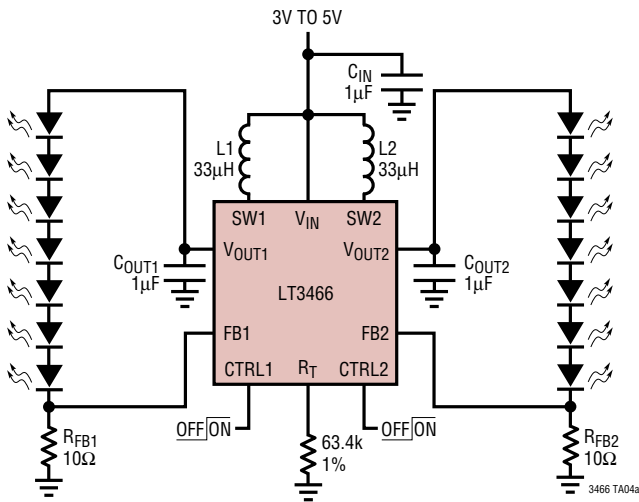

C_{IN}: TAIYO YUDEN JMK107BJ105
 C_{OUT1}, C_{OUT2}: TAIYO YUDEN GMK316BJ105
 L1, L2: TOKO A914BYW-330M

Conversion Efficiency

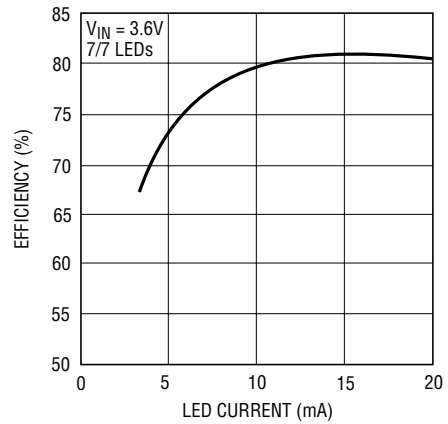

3466 TA04b

TYPICAL APPLICATIONS

Li-Ion to 8/8 White LEDs

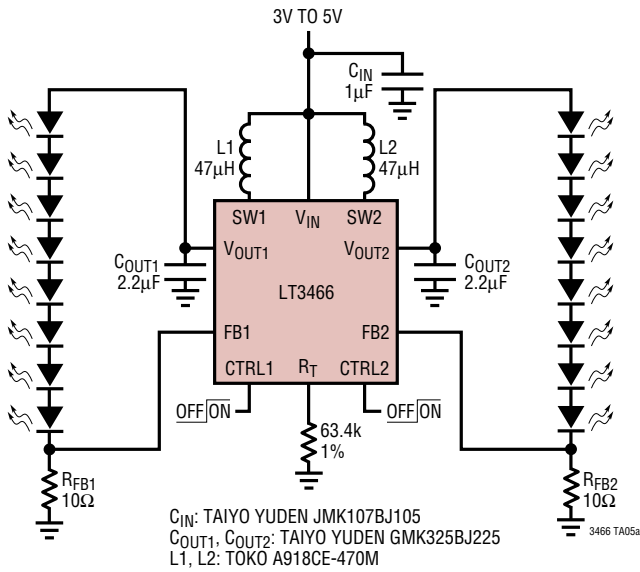

Conversion Efficiency

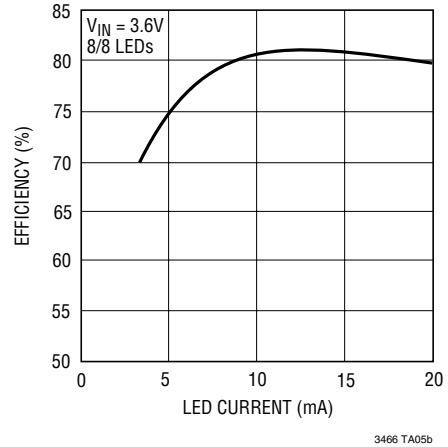

Li-Ion to 9/9 White LEDs

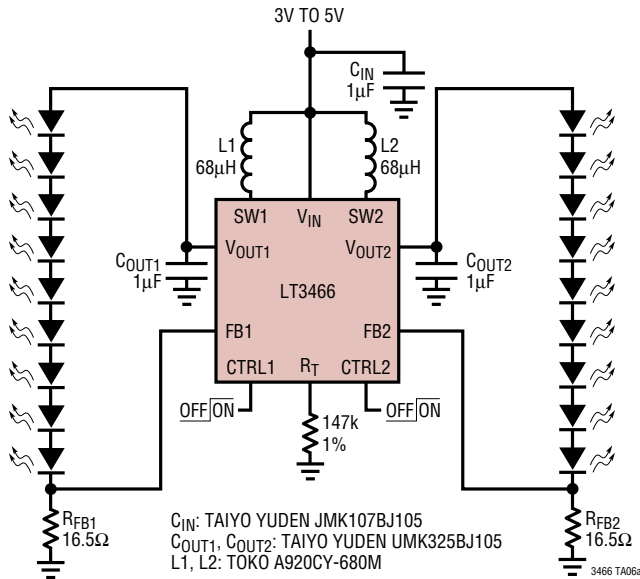

Conversion Efficiency

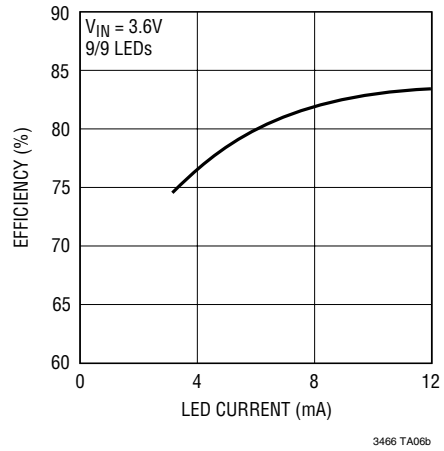

TYPICAL APPLICATIONS

Li-Ion to 10/10 White LEDs

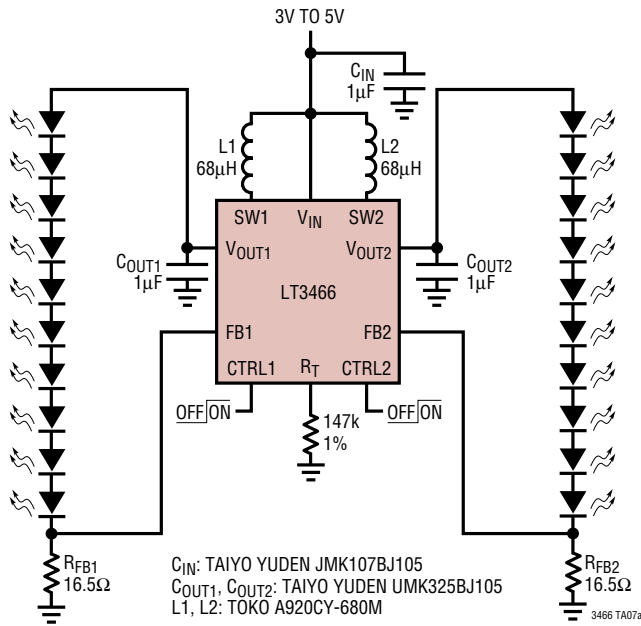

Conversion Efficiency

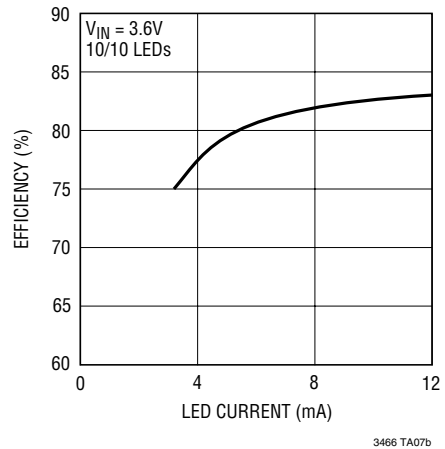

2 AA Cells to 2/2 White LEDs

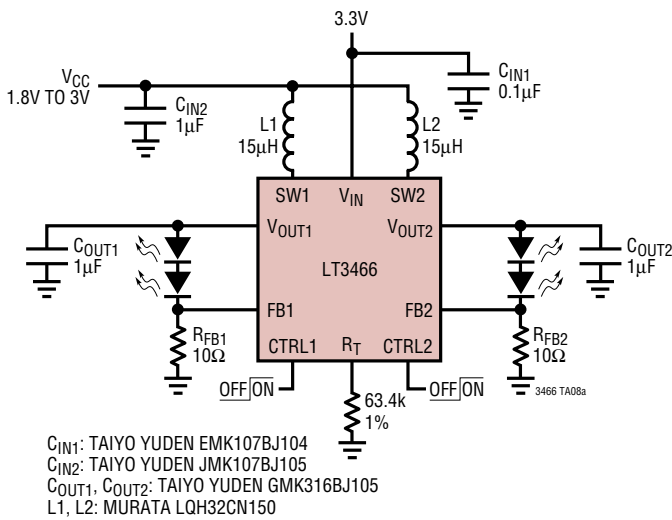

Conversion Efficiency

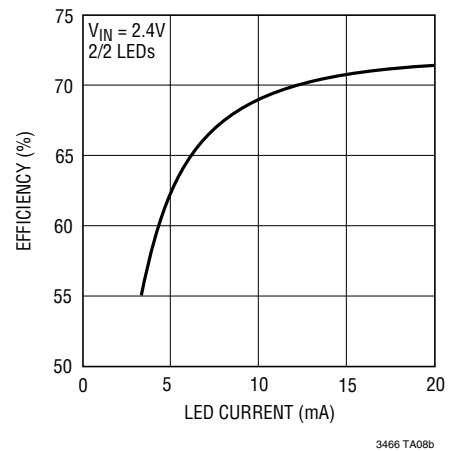

TYPICAL APPLICATIONS

2 Li-Ion Cells to 10/10 White LEDs

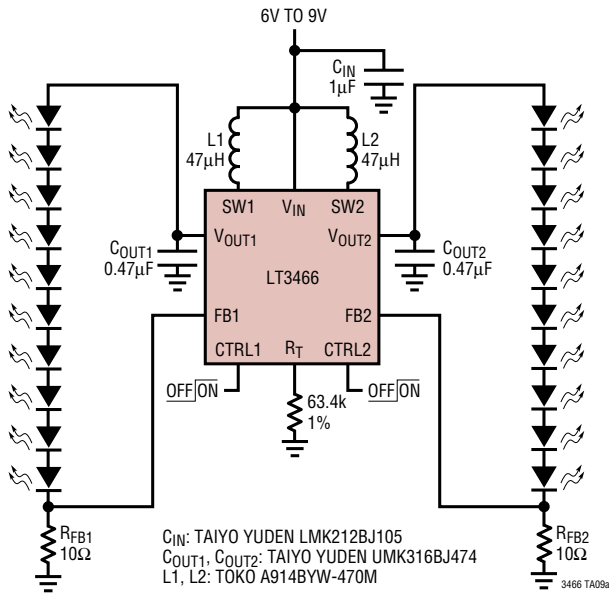

Conversion Efficiency

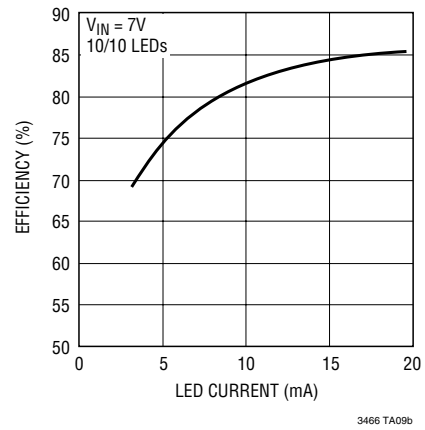

2 Li-Ion Cells to 16/16 White LEDs

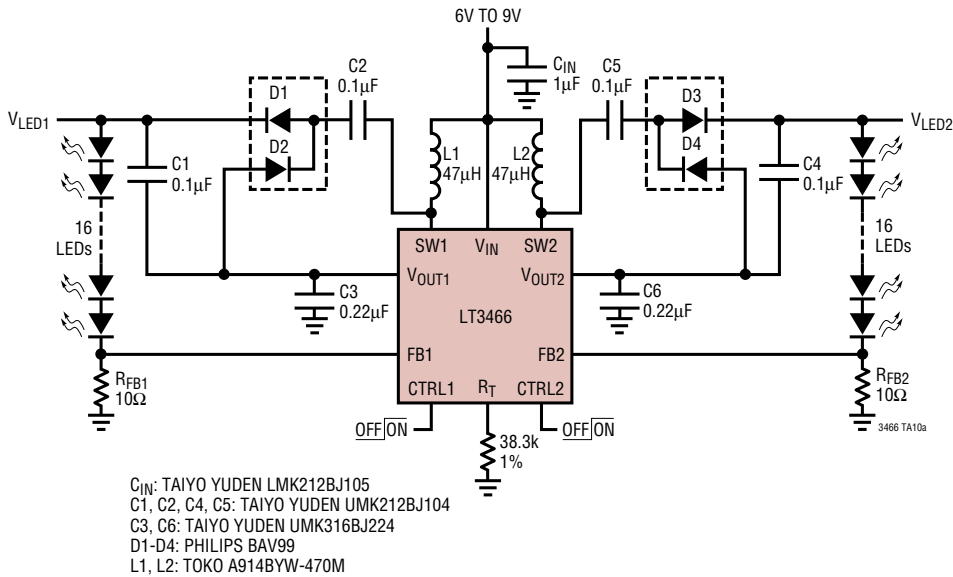

Conversion Efficiency

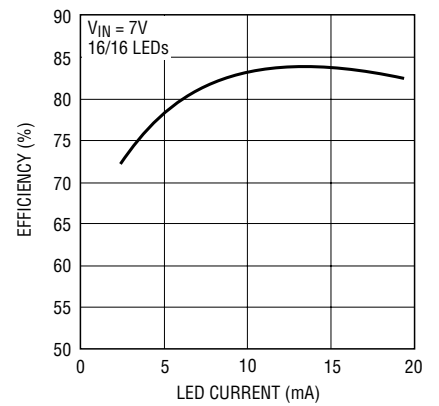

PACKAGE DESCRIPTION

DD Package 10-Lead Plastic DFN (3mm × 3mm) (Reference LTC DWG # 05-08-1699)

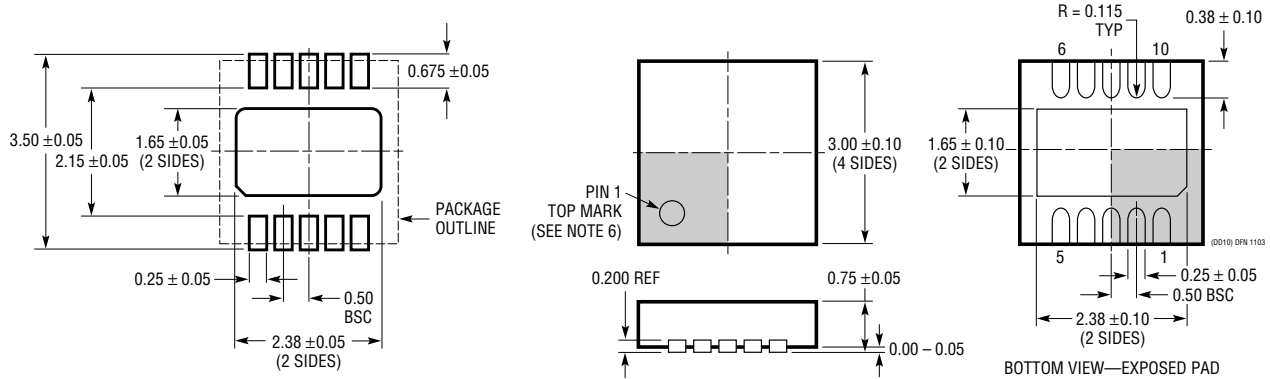

RECOMMENDED SOLDER PAD PITCH AND DIMENSIONS

- NOTE:
1. DRAWING TO BE MADE A JEDEC PACKAGE OUTLINE MO-229 VARIATION OF (WEED-2). CHECK THE LTC WEBSITE DATA SHEET FOR CURRENT STATUS OF VARIATION ASSIGNMENT
 2. DRAWING NOT TO SCALE
 3. ALL DIMENSIONS ARE IN MILLIMETERS
 4. DIMENSIONS OF EXPOSED PAD ON BOTTOM OF PACKAGE DO NOT INCLUDE MOLD FLASH. MOLD FLASH, IF PRESENT, SHALL NOT EXCEED 0.15mm ON ANY SIDE
 5. EXPOSED PAD SHALL BE SOLDER PLATED
 6. SHADED AREA IS ONLY A REFERENCE FOR PIN 1 LOCATION ON THE TOP AND BOTTOM OF PACKAGE

FE Package 16-Lead Plastic TSSOP (4.4mm) (Reference LTC DWG # 05-08-1663) Exposed Pad Variation BB

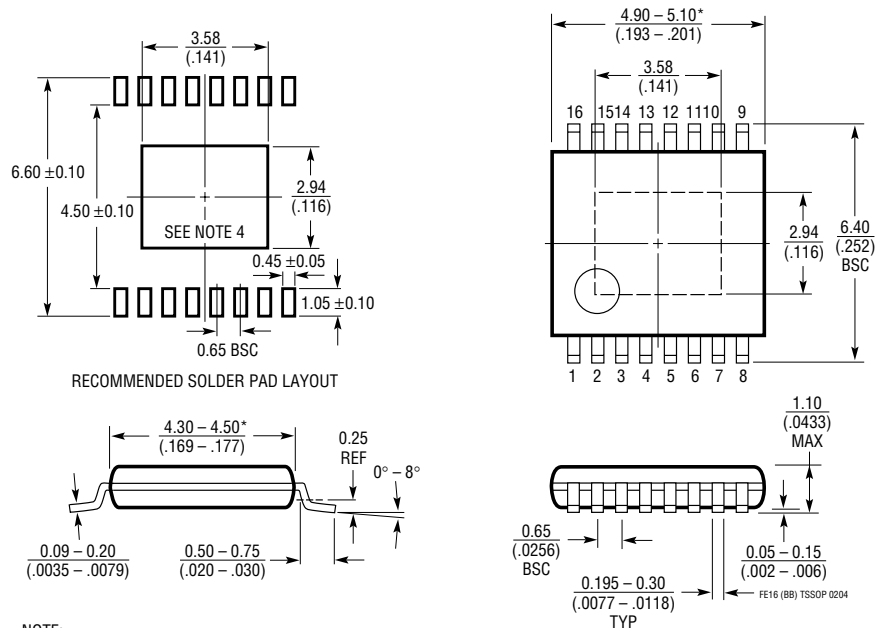

- NOTE:
1. CONTROLLING DIMENSION: MILLIMETERS
 2. DIMENSIONS ARE IN $\frac{\text{MILLIMETERS}}{\text{(INCHES)}}$
 3. DRAWING NOT TO SCALE
 4. RECOMMENDED MINIMUM PCB METAL SIZE FOR EXPOSED PAD ATTACHMENT
- *DIMENSIONS DO NOT INCLUDE MOLD FLASH. MOLD FLASH SHALL NOT EXCEED 0.150mm (.006") PER SIDE

TYPICAL APPLICATION

12V to 25/25 White LEDs

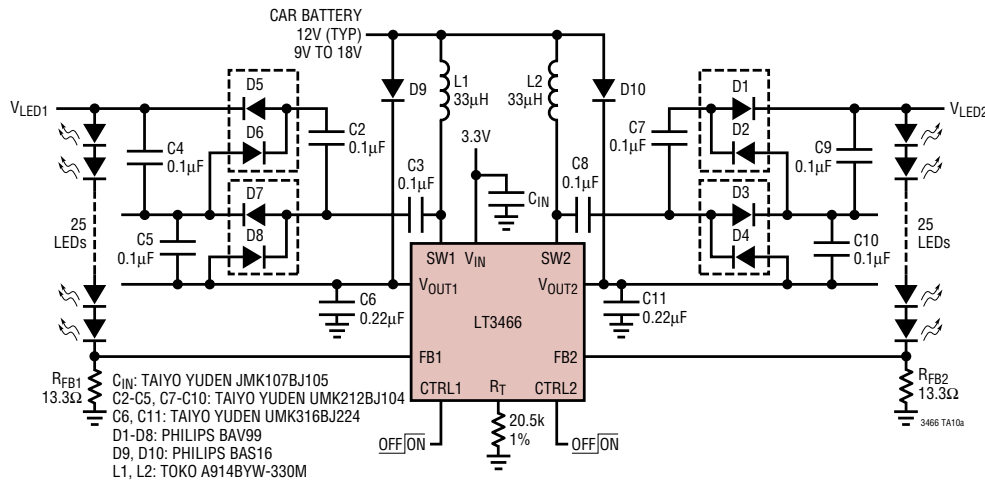

Conversion Efficiency

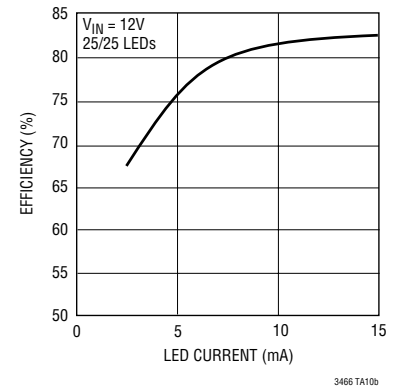

RELATED PARTS

PART NUMBER	DESCRIPTION	COMMENTS
LT1618	Constant Current, Constant Voltage 1.24MHz, High Efficiency Boost Regulator	Up to 16 White LEDs, V _{IN} : 1.6V to 18V, V _{OUT(MAX)} = 34V, I _Q = 1.8mA, I _{SD} < 1μA, MS Package
LT1932	Constant Current, 1.2MHz, High Efficiency White LED Boost Regulator	Up to 8 White LEDs, V _{IN} : 1V to 10V, V _{OUT(MAX)} = 34V, I _Q = 1.2mA, I _{SD} < 1μA, ThinSOT™ Package
LT1937	Constant Current, 1.2MHz, High Efficiency White LED Boost Regulator	Up to 4 White LEDs, V _{IN} : 2.5V to 10V, V _{OUT(MAX)} = 34V, I _Q = 1.9mA, I _{SD} < 1μA, ThinSOT, SC70 Packages
LTC3200	Low Noise, 2MHz, Regulated Charge Pump White LED Driver	Up to 6 White LEDs, V _{IN} : 2.7V to 4.5V, I _Q = 8mA, I _{SD} < 1μA, MS Package
LTC3201	Low Noise, 1.7MHz, Regulated Charge Pump White LED Driver	Up to 6 White LEDs, V _{IN} : 2.7V to 4.5V, I _Q = 6.5mA, I _{SD} < 1μA, MS Package
LTC3202	Low Noise, 1.5MHz, Regulated Charge Pump White LED Driver	Up to 8 White LEDs, V _{IN} : 2.7V to 4.5V, I _Q = 5mA, I _{SD} < 1μA, MS Package
LTC3205/LTC3206	High Efficiency, Multidisplay LED Controller	Up to 4 (Main), 2 (Sub) and RGB, V _{IN} : 2.8V to 4.5V, I _Q = 50μA, I _{SD} < 1μA, QFN-24 Package
LT3465/LT3465A	Constant Current, 1.2MHz/2.7MHz, High Efficiency White LED Boost Regulator with Integrated Schottky Diode	Up to Six White LEDs, V _{IN} : 2.7V to 16V, V _{OUT(MAX)} = 34V, I _Q = 1.9mA, I _{SD} < 1μA, ThinSOT Package

ThinSOT is a trademark of Linear Technology Corporation.