

15 GHz to 65 GHz, GaAs, MMIC, Double Balanced Mixer

FEATURES

- ▶ Conversion loss: 8 dB typical at 15 GHz to 50 GHz
- ▶ Input IP3 (downconverter): 20 dBm typical at 15 GHz to 50 GHz
- ▶ Input IP2 (downconverter): 40 dBm typical at 15 GHz to 50 GHz
- ▶ Input P1dB (upconverter): 11 dBm typical
- ▶ LO to RF isolation: 35 dB typical
- ▶ LO to IF isolation: 35 dB typical
- ▶ RF to IF isolation: 45 dB typical at 15 GHz to 50 GHz
- ▶ 18-terminal, RoHS compliant, 4 mm × 4 mm LGA package

APPLICATIONS

- ▶ Microwave and very small aperture terminal (VSAT) radios
- ▶ Test equipment
- ▶ Military electronic warfare (EW)
- ▶ Electronic countermeasure (ECM)
- ▶ Command, control, communications, and intelligence

FUNCTIONAL BLOCK DIAGRAM

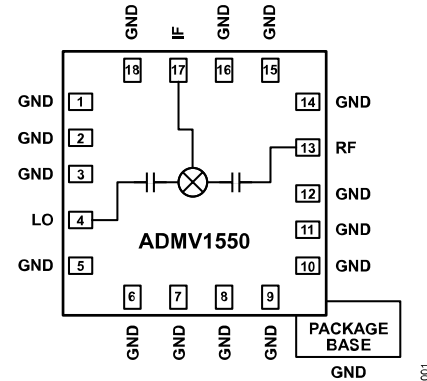

Figure 1. Functional Block Diagram

GENERAL DESCRIPTION

The ADMV1550 is a general-purpose, double balanced mixer in a leadless, RoHS compliant, surface-mount technology (SMT) package that can be used as an upconverter or downconverter between 15 GHz and 65 GHz. The wide bandwidth from DC to 20 GHz on the intermediate frequency (IF) port allows flexible frequency planning to avoid spurious products. This mixer is fabricated in a gallium arsenide (GaAs), monolithic microwave integrated circuit (MMIC) process and requires no external components or matching circuitry. The ADMV1550 provides excellent local oscillator (LO) to RF and LO to IF suppression due to optimized balun structures. The mixer operates with a typical LO amplitude 15 dBm. The RoHS-compliant ADMV1550 eliminates the need for wire bonding, allowing the use of surface-mount manufacturing techniques. The ADMV1550 is available in a compact 4 mm × 4 mm, 18-terminal land grid array (LGA) package and operates over -40°C to +85°C temperature range.

TABLE OF CONTENTS

Features.....	1	Upconverter Performance, IF = 1 GHz.....	18
Applications.....	1	Upconverter Performance, IF = 10 GHz.....	20
Functional Block Diagram.....	1	Upconverter Performance, IF = 15 GHz.....	22
General Description.....	1	Isolation and Return Loss.....	24
Specifications.....	3	IF Bandwidth—Downconverter.....	26
Pin Configuration and Function Descriptions.....	4	IF Bandwidth—Upconverter.....	28
Interface Schematics.....	4	M × N Spurious Outputs.....	30
Absolute Maximum Ratings.....	5	Theory of Operation.....	32
Thermal Resistance.....	5	Applications Information.....	33
Electrostatic Discharge (ESD) Ratings.....	5	Typical Application Circuit.....	33
Typical Performance Characteristics.....	6	Evaluation PCB Information.....	33
Downconverter Performance, IF = 1 GHz.....	6	Outline Dimensions.....	34
Downconverter Performance, IF = 10 GHz.....	10	Ordering Guide.....	34
Downconverter Performance, IF = 15 GHz.....	14	Evaluation Boards.....	34

REVISION HISTORY**8/2023—Revision 0: Initial Version**

SPECIFICATIONS

$T_A = 25^\circ\text{C}$, $IF = 1\text{ GHz}$, and $LO = 15\text{ dBm}$, with the upper sideband selected, unless otherwise noted. For frequencies greater than 62 GHz, the response is limited by the amplifier used for measurements due to the inability to drive LO power at high frequencies (see the [Typical Performance Characteristics](#) section).

Table 1. Specifications, 15 GHz to 50 GHz Performance

Parameter	Symbol	Min	Typ	Max	Unit
FREQUENCY RANGE					
RF Pin		15		50	GHz
IF Pin		DC		20	GHz
LO Pin		15		50	GHz
LO AMPLITUDE					
		13	15	17	dBm
RF PERFORMANCE					
Downconverter					
Conversion Loss			8		dB
Single Sideband Noise Figure			7		dB
Input Third-Order Intercept	IP3		20		dBm
Input 1 dB Compression Point	P1dB		10		dBm
Input Second-Order Intercept	IP2		40		dBm
Upconverter					
Conversion Loss			8	11	dB
Input Third-Order Intercept	IP3		18		dBm
Input 1 dB Compression Point	P1dB		11		dBm
ISOLATION					
LO to IF			35		dB
RF to IF			45		dB
LO to RF			35		dB

Table 2. Specifications, 50 GHz to 65 GHz Performance

Parameter	Symbol	Min	Typ	Max	Unit
FREQUENCY RANGE					
RF Pin		50		65	GHz
IF Pin		DC		20	GHz
LO Pin		50		65	GHz
LO AMPLITUDE					
		13	15	17	dBm
RF PERFORMANCE					
Downconverter					
Conversion Loss			10	13	dB
Single Sideband Noise Figure			10		dB
Input Third-Order Intercept	IP3		15		dBm
Input 1 dB Compression Point	P1dB		10		dBm
Input Second-Order Intercept	IP2		35		dBm
Upconverter					
Conversion Loss			10	13	dB
Input Third-Order Intercept	IP3		15		dBm
Input 1 dB Compression Point	P1dB		11		dBm
ISOLATION					
LO to IF			35		dB
RF to IF			40		dB
LO to RF			35		dB

PIN CONFIGURATION AND FUNCTION DESCRIPTIONS

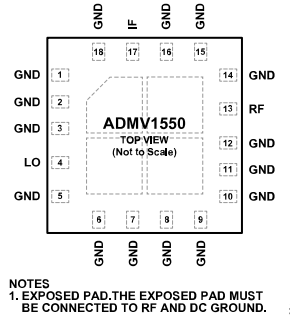

Figure 2. Pin Configuration

Table 3. Pin Function Descriptions

Pin No.	Mnemonic	Description
1 to 3, 5 to 12, 14 to 16, 18	GND	Ground. These GND pins must be connected to RF and dc ground. See Figure 3 for the interface schematic.
4	LO	LO Port. The LO pin is AC-coupled and matched to 50 Ω. See Figure 4 for the interface schematic.
13	RF	RF Port. The RF pin is AC-coupled and matched to 50 Ω. See Figure 5 for the interface schematic.
17	IF	IF Port. The IF pin is DC-coupled and matched to 50 Ω. For applications not requiring operation to DC, DC block this port externally using a series capacitor of a value chosen to pass the necessary RF frequency range. For operation to DC, the IF pin must not source or sink more than 19 mA of current. Otherwise, device malfunction or device failure may result. See Figure 6 for the interface schematic.
	EPAD	Exposed Pad. The exposed pad must be connected to RF and dc ground.

INTERFACE SCHEMATICS



Figure 3. GND Interface Schematic

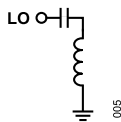

Figure 4. LO Interface Schematic

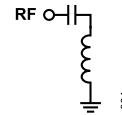

Figure 5. RF Interface Schematic

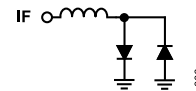

Figure 6. IF Interface Schematic

ABSOLUTE MAXIMUM RATINGS

Table 4. Absolute Maximum Ratings

Parameter	Rating
RF Input Power	25 dBm
LO Input Power	25 dBm
IF Input Power	25 dBm
IF Current	19 mA
Continuous Power Dissipation, P_{DISS} ($T_A = 85^\circ\text{C}$, Derates 1.65 mW/ $^\circ\text{C}$ Above 85°C)	108 mW
Peak Reflow Temperature (Moisture Sensitivity Level (MSL) 3) ¹	260 $^\circ\text{C}$
Junction Temperature (T_J)	150 $^\circ\text{C}$
Lifetime at Maximum Temperature (T_J)	1 Million Hours
Operating Temperature Range	-40 $^\circ\text{C}$ to +85 $^\circ\text{C}$
Storage Temperature Range	-65 $^\circ\text{C}$ to +150 $^\circ\text{C}$
Lead Temperature Range	-65 $^\circ\text{C}$ to +150 $^\circ\text{C}$

¹ Based on IPC/JEDEC J-STD-20 MSL classifications.

Stresses at or above those listed under Absolute Maximum Ratings may cause permanent damage to the product. This is a stress rating only; functional operation of the product at these or any other conditions above those indicated in the operational section of this specification is not implied. Operation beyond the maximum operating conditions for extended periods may affect product reliability.

THERMAL RESISTANCE

Thermal performance is directly linked to printed circuit board (PCB) design and operating environment. Careful attention to PCB thermal design is required.

θ_{JA} is the junction to ambient thermal resistance, and θ_{JC} is the junction to case thermal resistance.

Table 5. Thermal Resistance

Package Type ¹	θ_{JA}	θ_{JC}	Unit
CC-18-2	50.28	602.5	$^\circ\text{C}/\text{W}$

¹ Thermal resistance values specified are simulated based on JEDEC specifications in compliance with JESD-51.

ELECTROSTATIC DISCHARGE (ESD) RATINGS

The following ESD information is provided for handling of ESD-sensitive devices in an ESD protected area only.

Human body model (HBM) per ANSI/ESDA/JEDEC JS-001.

Field induced charged device model (FICDM) per ANSI/ESDA/JEDEC JS-002.

ESD Ratings for ADMV1550

Table 6. ADMV1550, 18-Terminal LGA

ESD Model	Withstand Threshold (V)	Class
HBM	750	1B
FICDM	500	C2a

ESD Caution



ESD (electrostatic discharge) sensitive device. Charged devices and circuit boards can discharge without detection. Although this product features patented or proprietary protection circuitry, damage may occur on devices subjected to high energy ESD. Therefore, proper ESD precautions should be taken to avoid performance degradation or loss of functionality.

TYPICAL PERFORMANCE CHARACTERISTICS

DOWNCONVERTER PERFORMANCE, IF = 1 GHz

Upper Sideband (Low-Side LO)

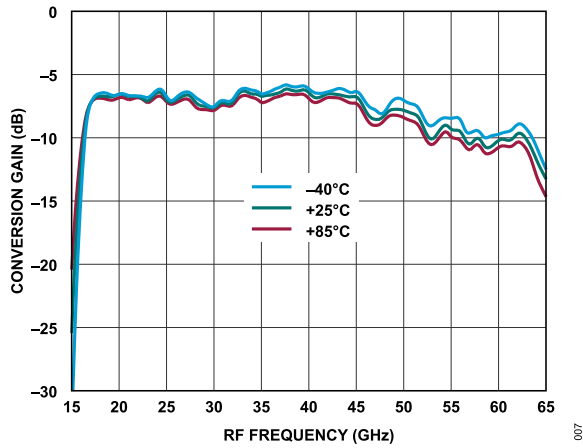

Figure 7. Conversion Gain vs. RF Frequency at Various Temperatures, LO = 15 dBm

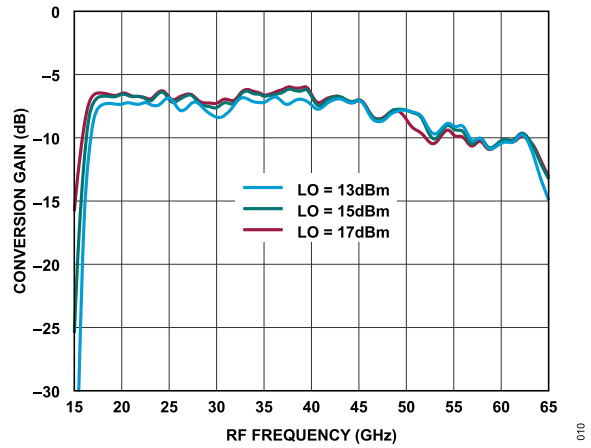

Figure 10. Conversion Gain vs. RF Frequency at Various LO Power Levels, $T_A = 25^\circ\text{C}$

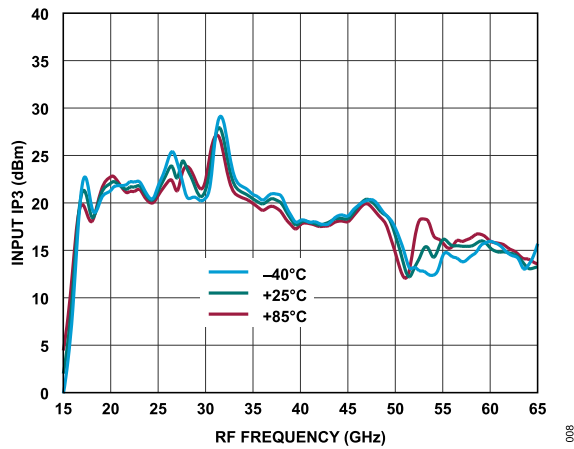

Figure 8. Input IP3 vs. RF Frequency at Various Temperatures, LO = 15 dBm

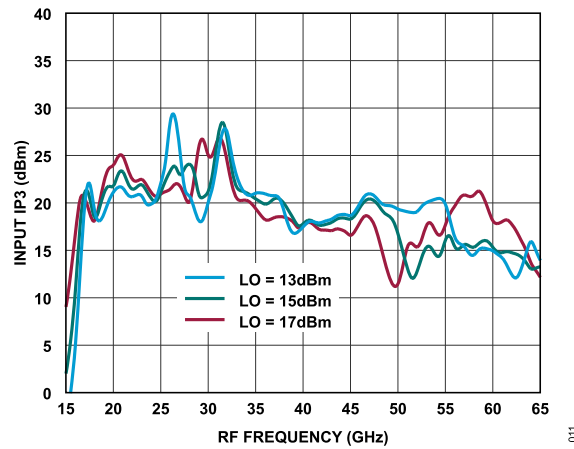

Figure 11. Input IP3 vs. RF Frequency at Various LO Power Levels, $T_A = 25^\circ\text{C}$

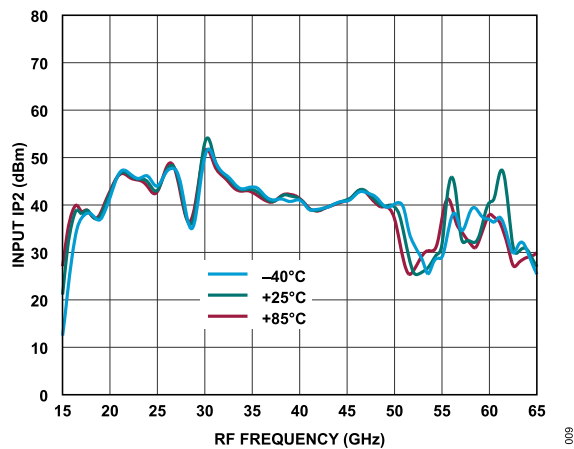

Figure 9. Input IP2 vs. RF Frequency at Various Temperatures, LO = 15 dBm

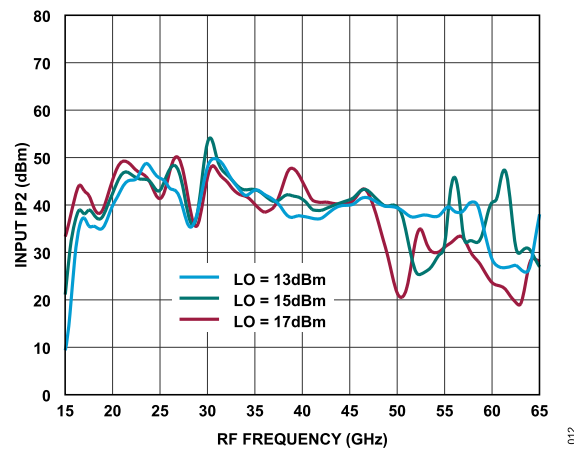

Figure 12. Input IP2 vs. RF Frequency at Various LO Power Levels, $T_A = 25^\circ\text{C}$

TYPICAL PERFORMANCE CHARACTERISTICS

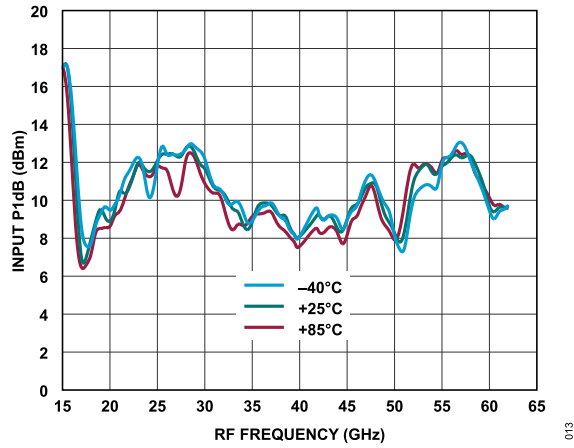

Figure 13. Input P1dB vs. RF Frequency at Various Temperatures, LO = 15 dBm

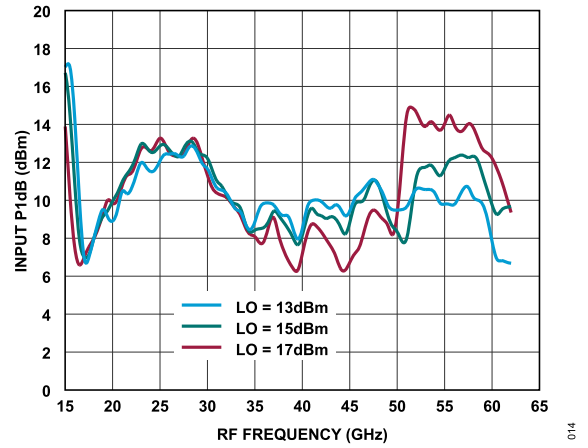

Figure 14. Input P1dB vs. RF Frequency at Various LO Power Levels, TA = 25°C

TYPICAL PERFORMANCE CHARACTERISTICS

Lower Sideband (High-Side LO)

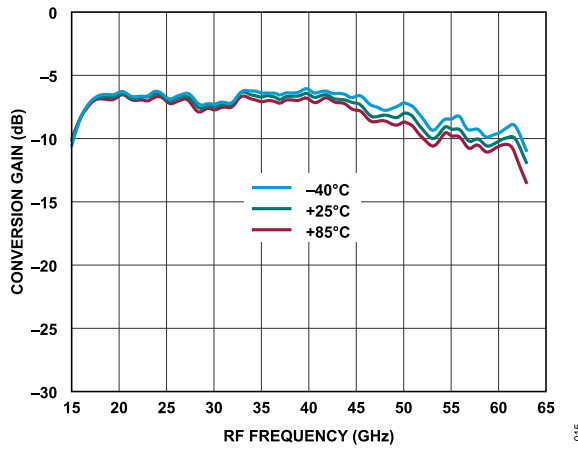

Figure 15. Conversion Gain vs. RF Frequency at Various Temperatures, LO = 15 dBm

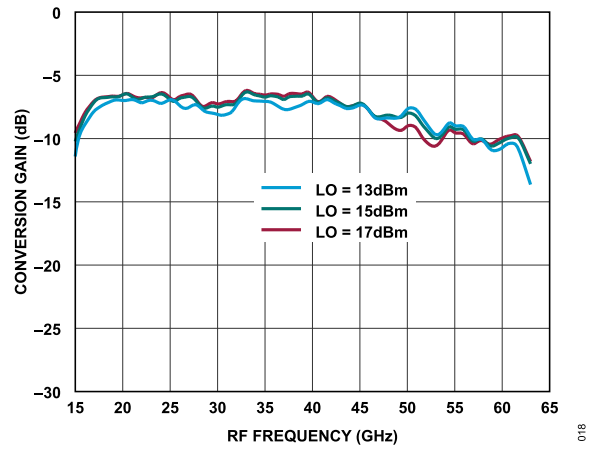

Figure 18. Conversion Gain vs. RF Frequency at Various LO Power Levels, $T_A = 25^\circ\text{C}$

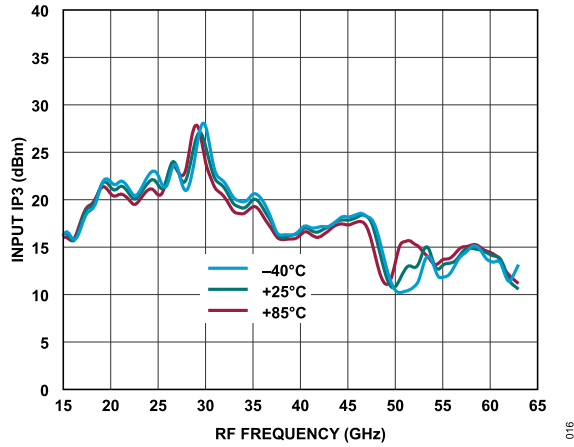

Figure 16. Input IP3 vs. RF Frequency at Various Temperatures, LO = 15 dBm

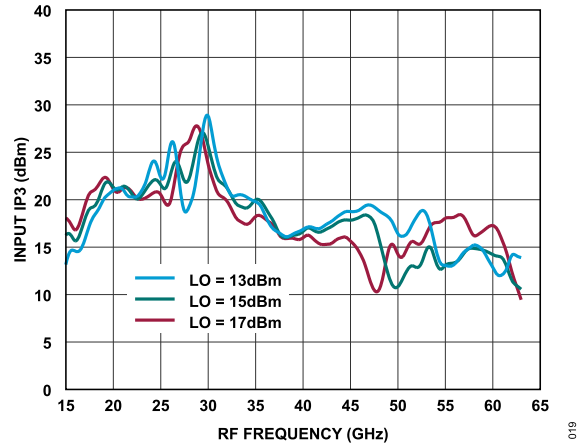

Figure 19. Input IP3 vs. RF Frequency at Various LO Power Levels, $T_A = 25^\circ\text{C}$

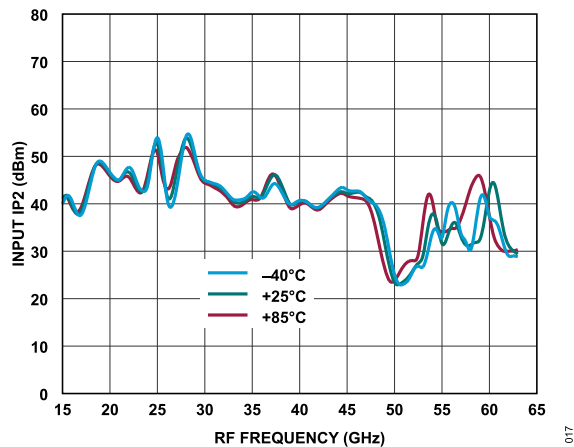

Figure 17. Input IP2 vs. RF Frequency at Various Temperatures, LO = 15 dBm

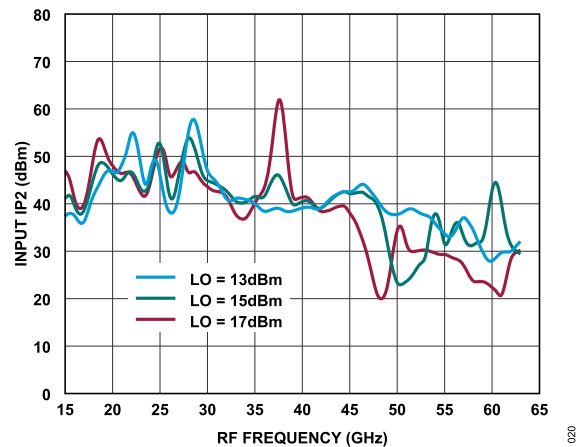

Figure 20. Input IP2 vs. RF Frequency at Various LO Power Levels, $T_A = 25^\circ\text{C}$

TYPICAL PERFORMANCE CHARACTERISTICS

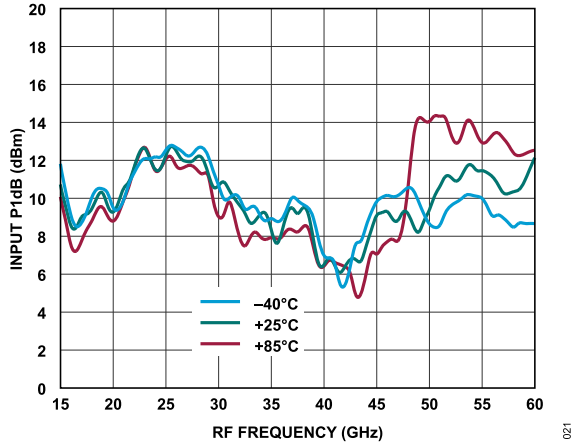

Figure 21. Input P1dB vs. RF Frequency at Various Temperatures, LO = 15 dBm

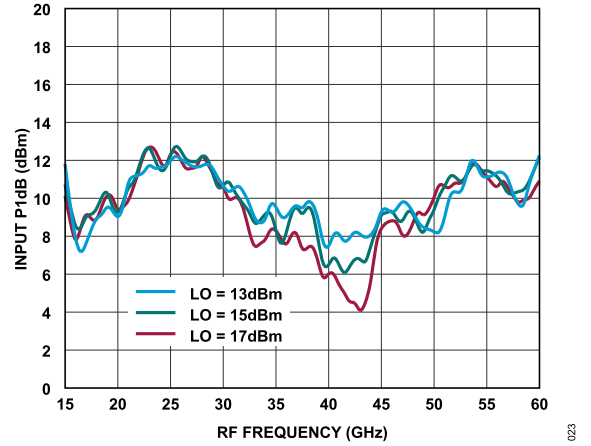

Figure 23. Input P1dB vs. RF Frequency at Various LO Power Levels, TA = 25°C

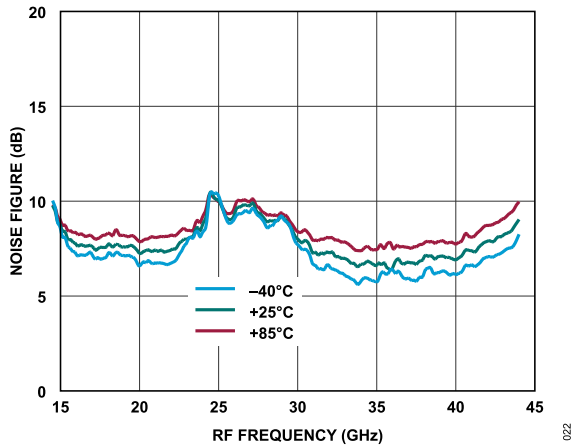

Figure 22. Noise Figure vs. RF Frequency at Various Temperatures, LO = 15 dBm

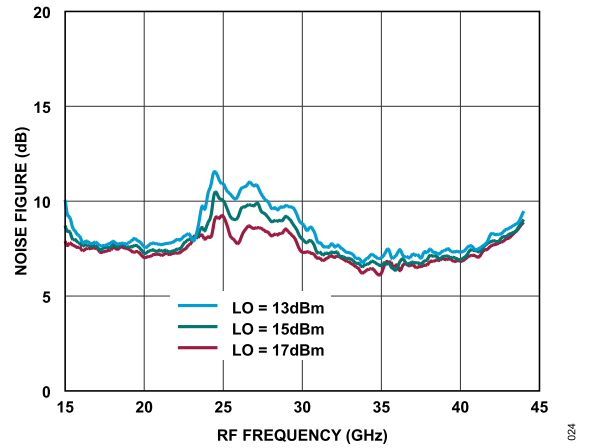

Figure 24. Noise Figure vs. RF Frequency at Various LO Power Levels, TA = 25°C

TYPICAL PERFORMANCE CHARACTERISTICS

DOWNCONVERTER PERFORMANCE, IF = 10 GHz

Upper Sideband (Low-Side LO)

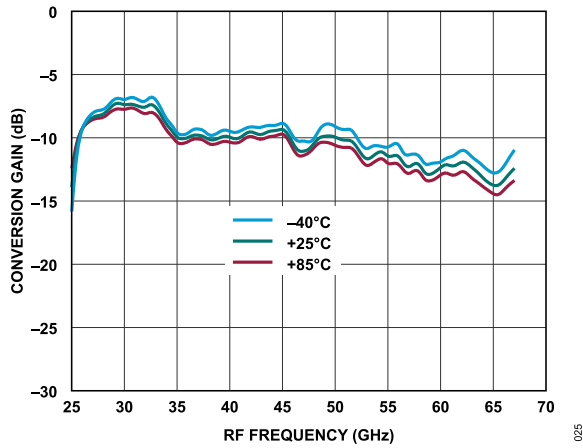

Figure 25. Conversion Gain vs. RF Frequency at Various Temperatures, LO = 15 dBm

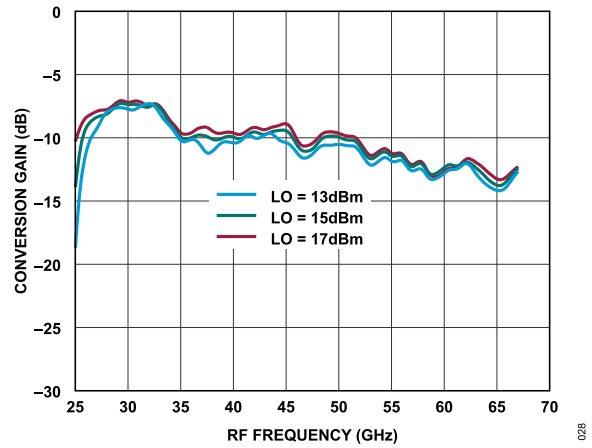

Figure 28. Conversion Gain vs. RF Frequency at Various LO Power Levels, $T_A = 25^\circ\text{C}$

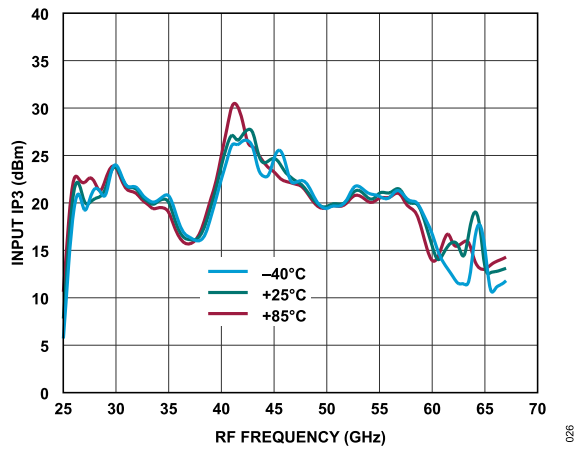

Figure 26. Input IP3 vs. RF Frequency at Various Temperatures, LO = 15 dBm

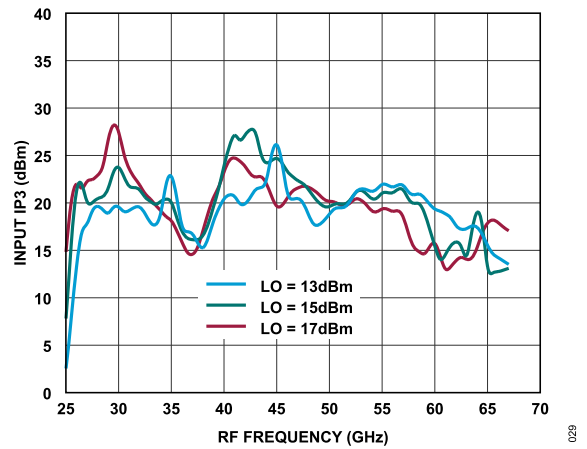

Figure 29. Input IP3 vs. RF Frequency at Various LO Power Levels, $T_A = 25^\circ\text{C}$

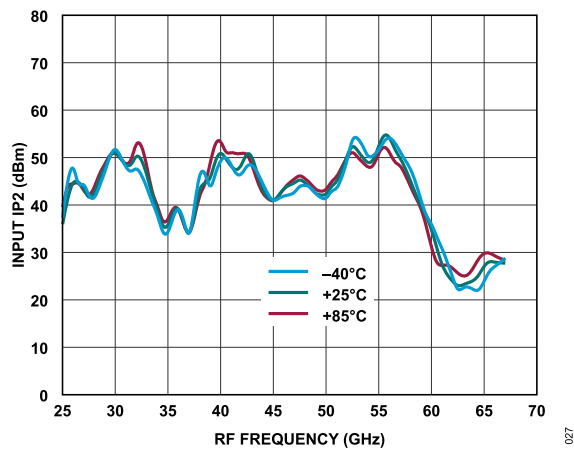

Figure 27. Input IP2 vs. RF Frequency at Various Temperatures, LO = 15 dBm

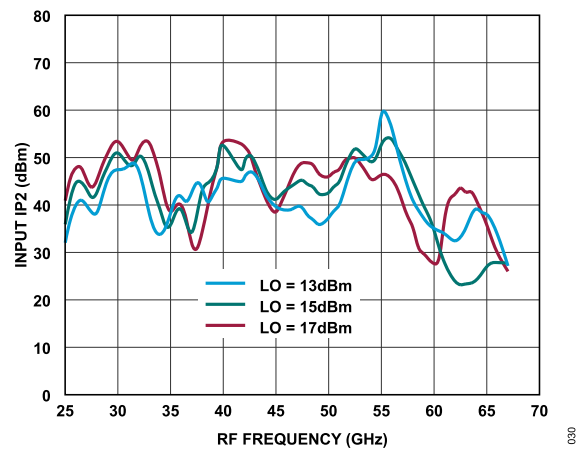

Figure 30. Input IP2 vs. RF Frequency at Various LO Power Levels, $T_A = 25^\circ\text{C}$

TYPICAL PERFORMANCE CHARACTERISTICS

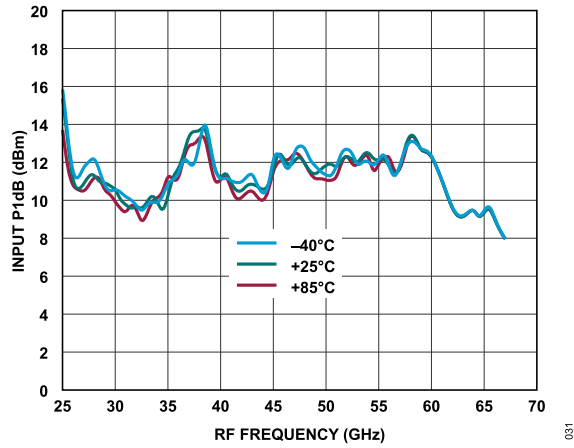

Figure 31. Input P1dB vs. RF Frequency at Various Temperatures, LO = 15 dBm

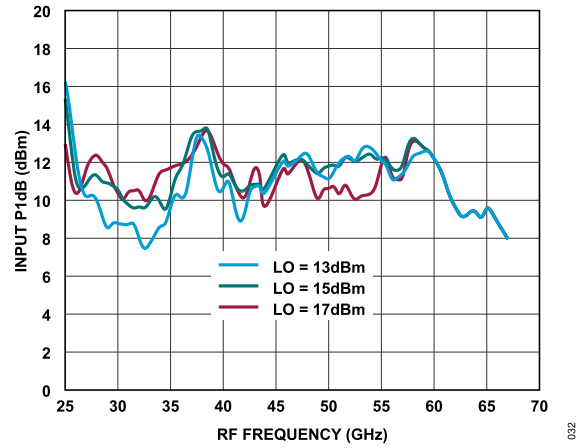

Figure 32. Input P1dB vs. RF Frequency at Various LO Power Levels, TA = 25°C

TYPICAL PERFORMANCE CHARACTERISTICS

Lower Sideband (High-Side LO)

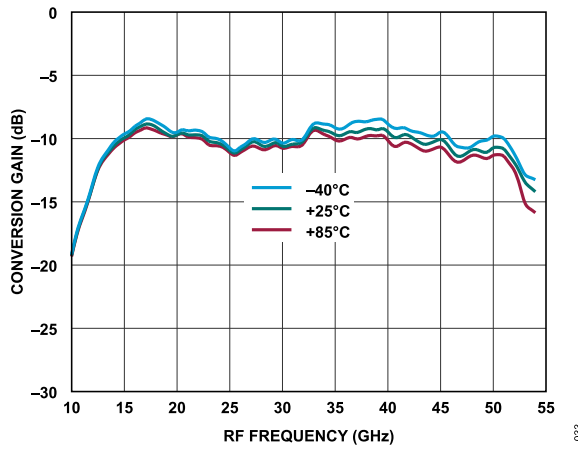

Figure 33. Conversion Gain vs. RF Frequency at Various Temperatures, LO = 15 dBm

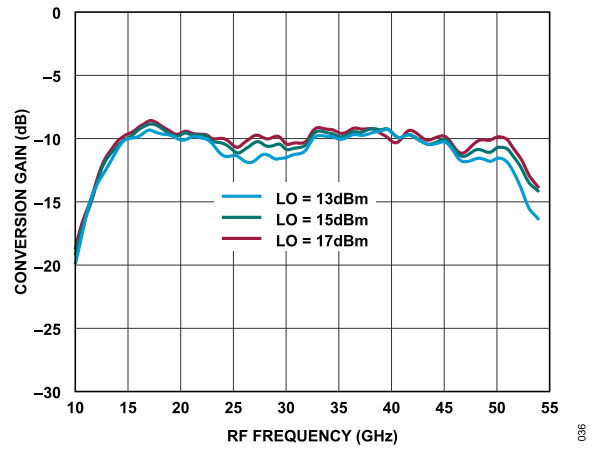

Figure 36. Conversion Gain vs. RF Frequency at Various LO Power Levels, $T_A = 25^\circ\text{C}$

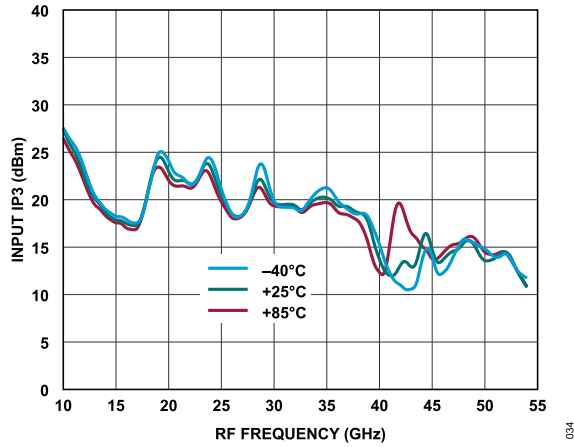

Figure 34. Input IP3 vs. RF Frequency at Various Temperatures, LO = 15 dBm

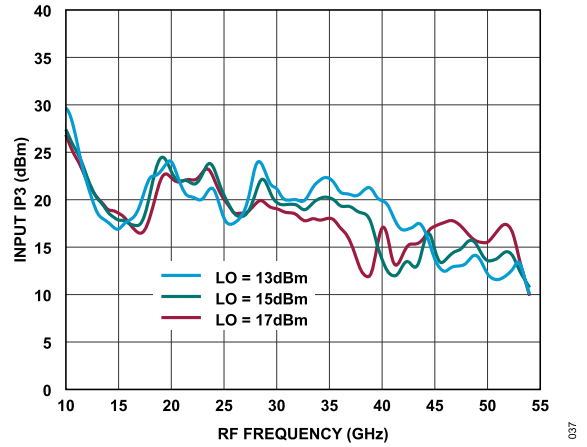

Figure 37. Input IP3 vs. RF Frequency at Various LO Power Levels, $T_A = 25^\circ\text{C}$

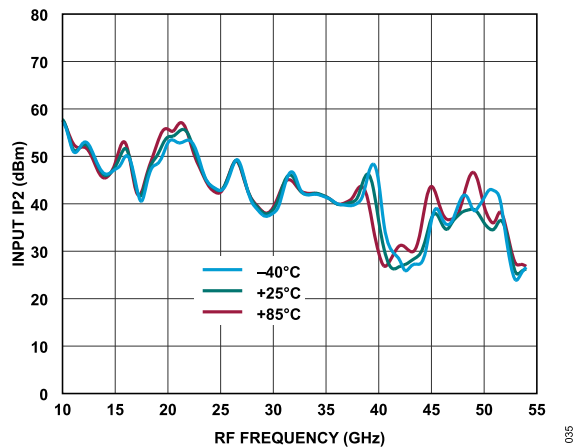

Figure 35. Input IP2 vs. RF Frequency at Various Temperatures, LO = 15 dBm

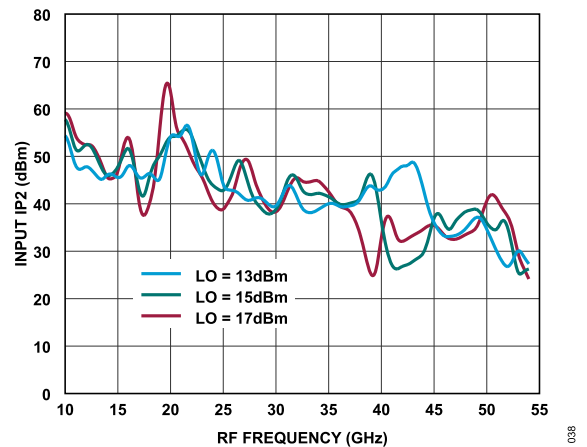

Figure 38. Input IP2 vs. RF Frequency at Various LO Power Levels, $T_A = 25^\circ\text{C}$

TYPICAL PERFORMANCE CHARACTERISTICS

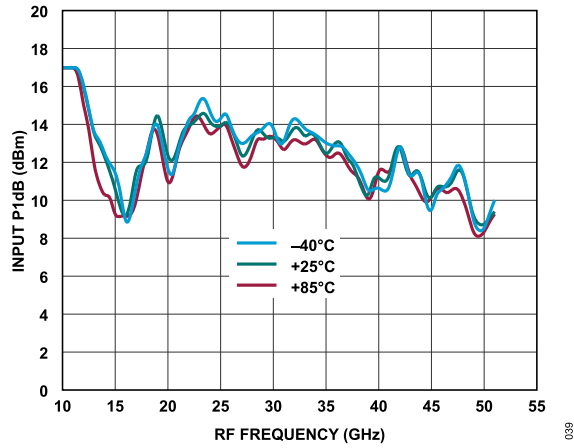

Figure 39. Input P1dB vs. RF Frequency at Various Temperatures, LO = 15 dBm

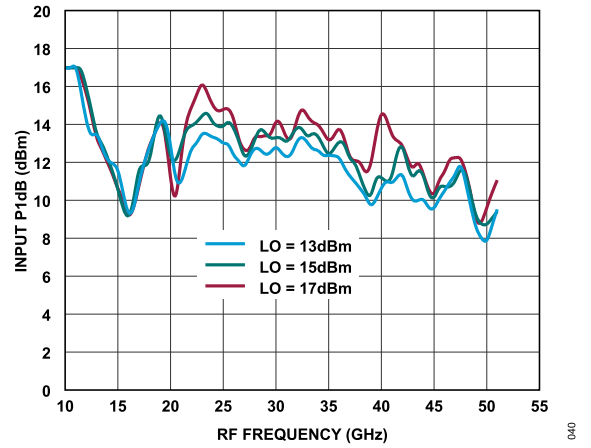

Figure 40. Input P1dB vs. RF Frequency at Various LO Power Levels, TA = 25°C

TYPICAL PERFORMANCE CHARACTERISTICS

DOWNCONVERTER PERFORMANCE, IF = 15 GHz

Upper Sideband (Low-Side LO)

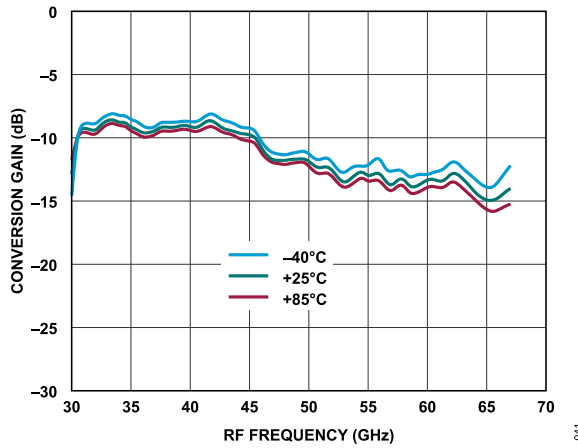

Figure 41. Conversion Gain vs. RF Frequency at Various Temperatures, LO = 15 dBm

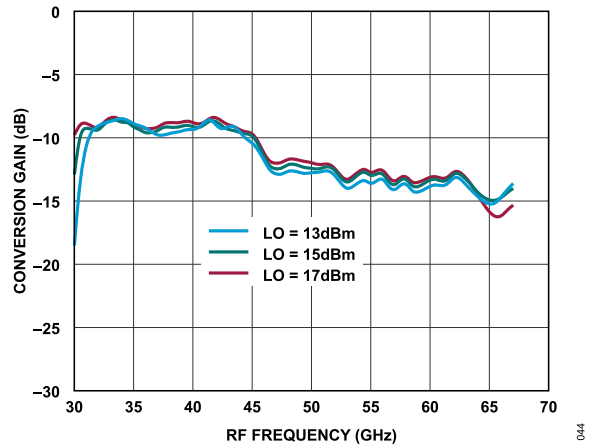

Figure 44. Conversion Gain vs. RF Frequency at Various LO Power Levels, $T_A = 25^\circ\text{C}$

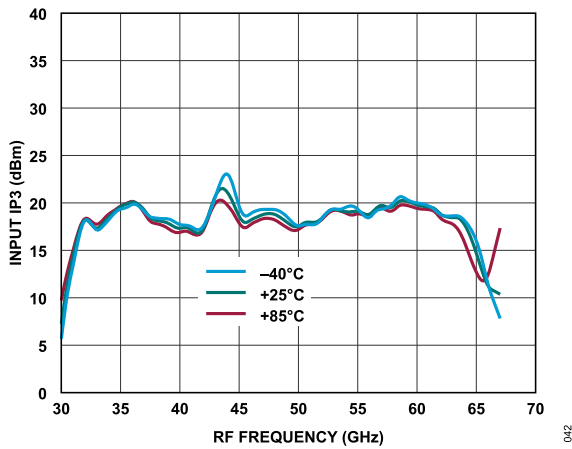

Figure 42. Input IP3 vs. RF Frequency at Various Temperatures, LO = 15 dBm

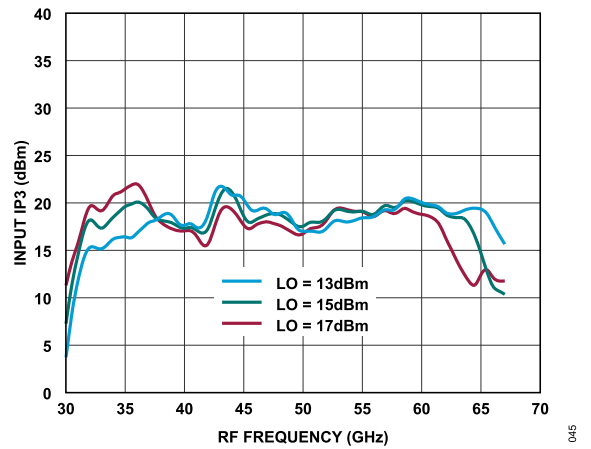

Figure 45. Input IP3 vs. RF Frequency at Various LO Power Levels, $T_A = 25^\circ\text{C}$

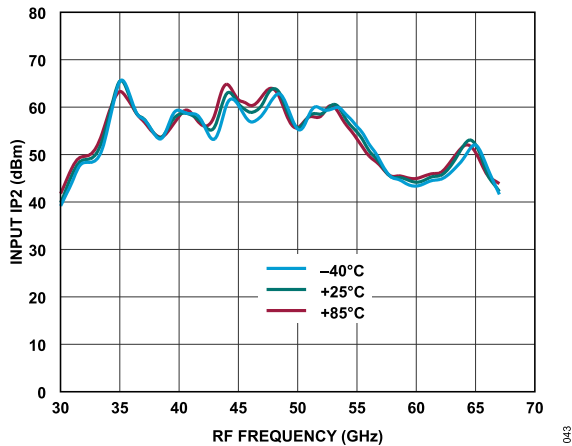

Figure 43. Input IP2 vs. RF Frequency at Various Temperatures, LO = 15 dBm

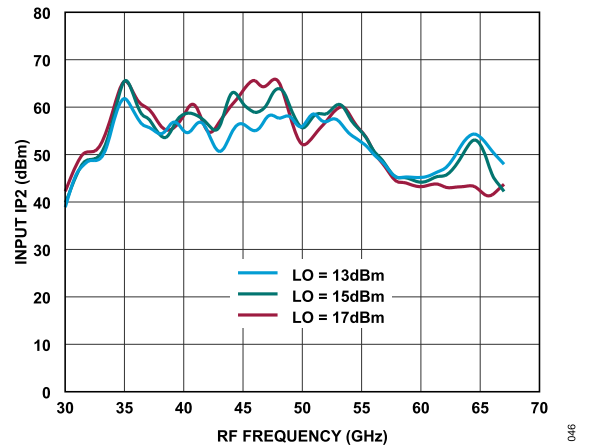

Figure 46. Input IP2 vs. RF Frequency at Various LO Power Levels, $T_A = 25^\circ\text{C}$

TYPICAL PERFORMANCE CHARACTERISTICS

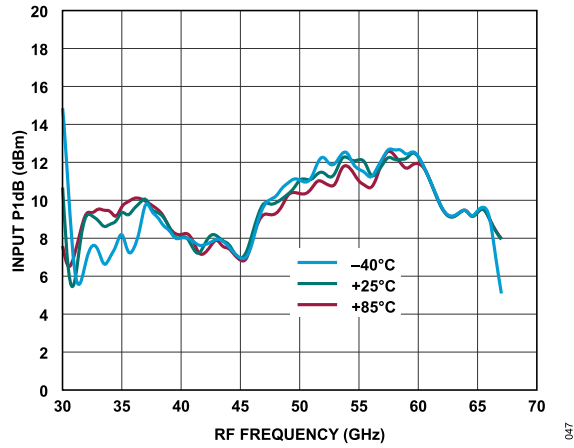

Figure 47. Input P1dB vs. RF Frequency at Various Temperatures, LO = 15 dBm

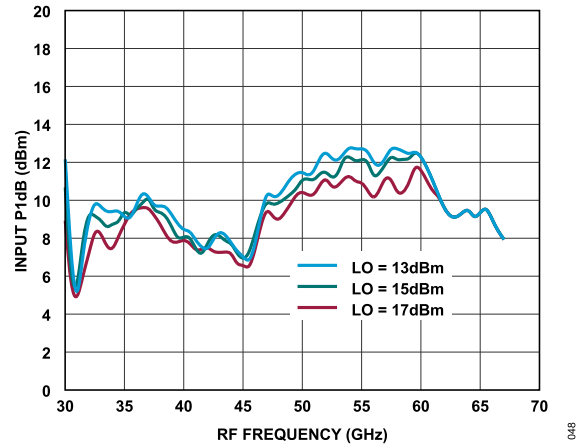

Figure 48. Input P1dB vs. RF Frequency at Various LO Power Levels, TA = 25°C

TYPICAL PERFORMANCE CHARACTERISTICS

Lower Sideband (High-Side LO)

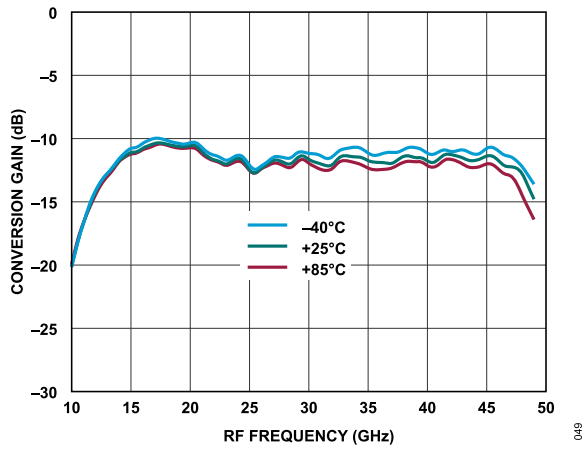

Figure 49. Conversion Gain vs. RF Frequency at Various Temperatures, LO = 15 dBm

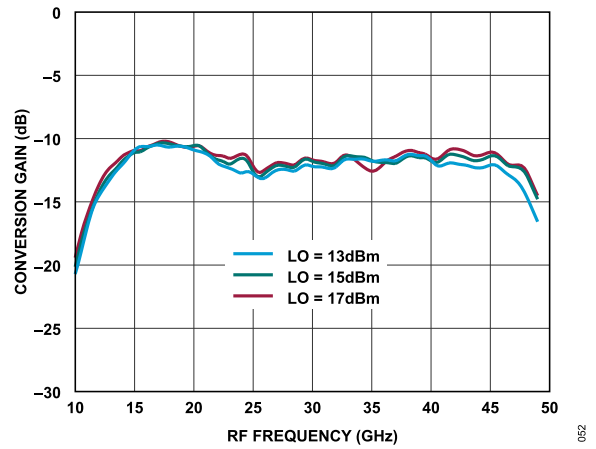

Figure 52. Conversion Gain vs. RF Frequency at Various LO Power Levels, $T_A = 25^\circ\text{C}$

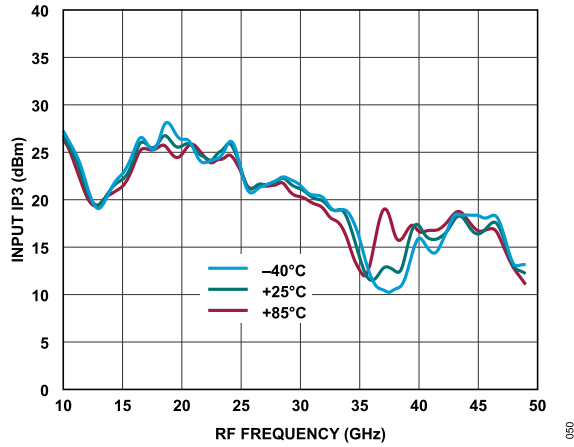

Figure 50. Input IP3 vs. RF Frequency at Various Temperatures, LO = 15 dBm

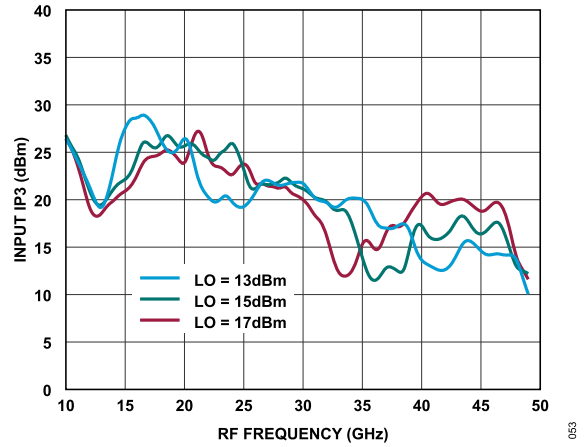

Figure 53. Input IP3 vs. RF Frequency at Various LO Power Levels, $T_A = 25^\circ\text{C}$

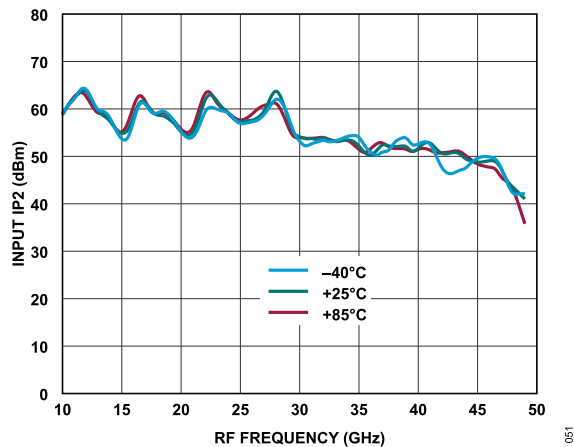

Figure 51. Input IP2 vs. RF Frequency at Various Temperatures, LO = 15 dBm

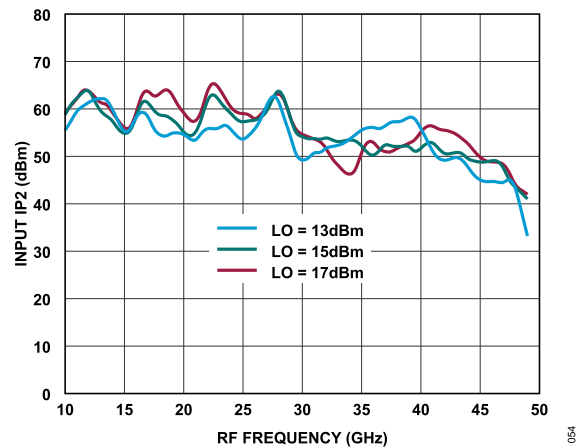

Figure 54. Input IP2 vs. RF Frequency at Various LO Power Levels, $T_A = 25^\circ\text{C}$

TYPICAL PERFORMANCE CHARACTERISTICS

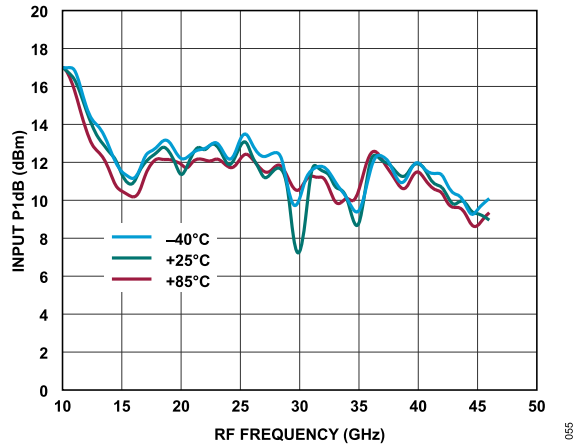

Figure 55. Input P1dB vs. RF Frequency at Various Temperatures, LO = 15 dBm

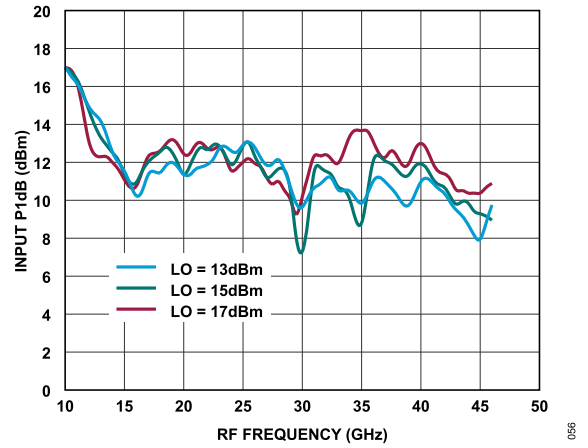

Figure 56. Input P1dB vs. RF Frequency at Various LO Power Levels, TA = 25°C

TYPICAL PERFORMANCE CHARACTERISTICS

UPCONVERTER PERFORMANCE, IF = 1 GHz

Upper Sideband (Low-Side LO)

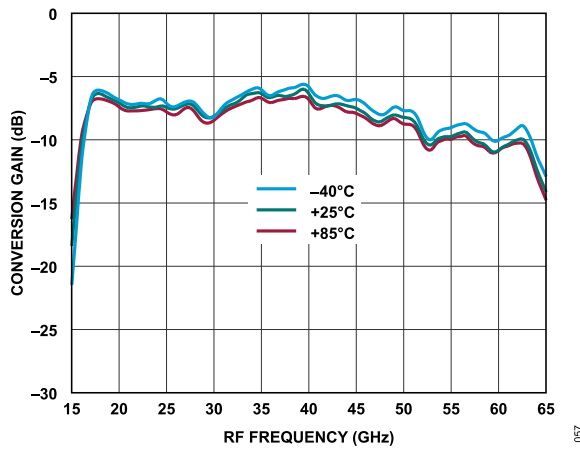

Figure 57. Conversion Gain vs. RF Frequency at Various Temperatures, LO = 15 dBm

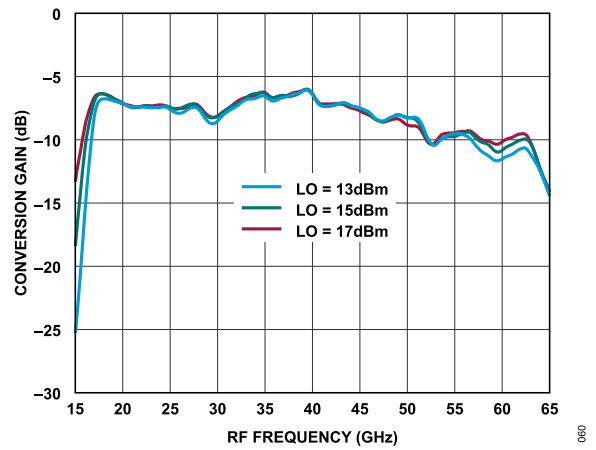

Figure 60. Conversion Gain vs. RF Frequency at Various LO Power Levels, TA = 25°C

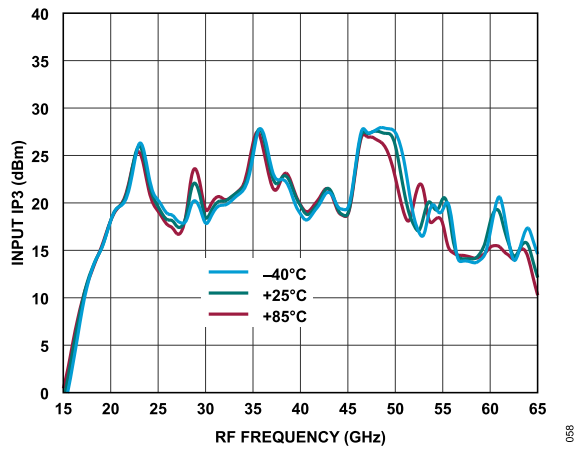

Figure 58. Input IP3 vs. RF Frequency at Various Temperatures, LO = 15 dBm

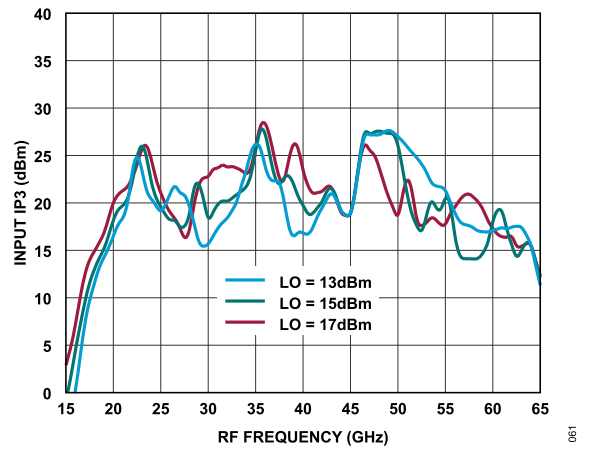

Figure 61. Input IP3 vs. RF Frequency at Various LO Power Levels, TA = 25°C

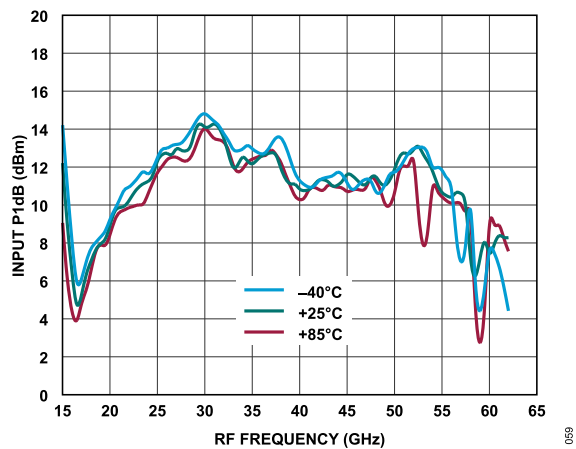

Figure 59. Input P1dB vs. RF Frequency at Various Temperatures, LO = 15 dBm

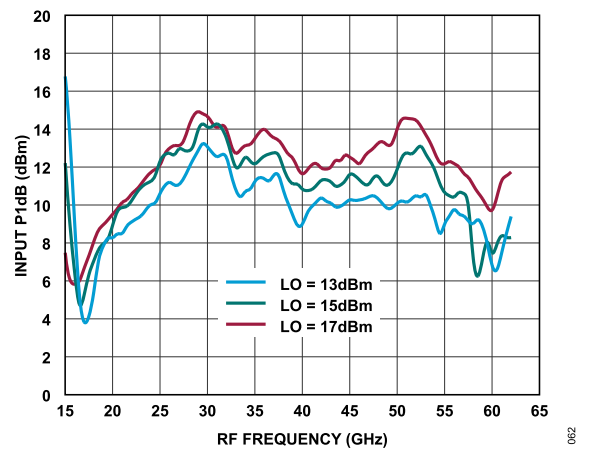

Figure 62. Input P1dB vs. RF Frequency at Various LO Power Levels, TA = 25°C

TYPICAL PERFORMANCE CHARACTERISTICS

Lower Sideband (High-Side LO)

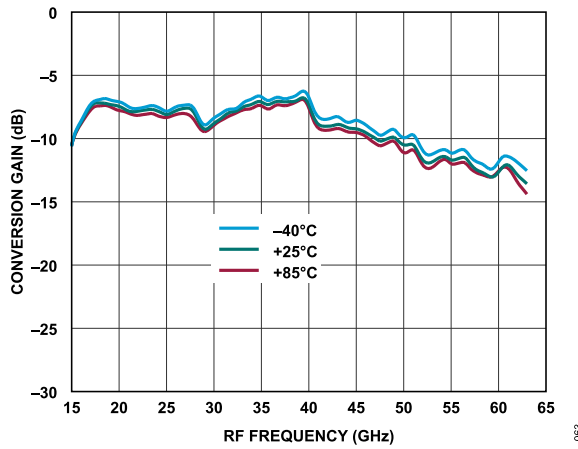

Figure 63. Conversion Gain vs. RF Frequency at Various Temperatures, LO = 15 dBm

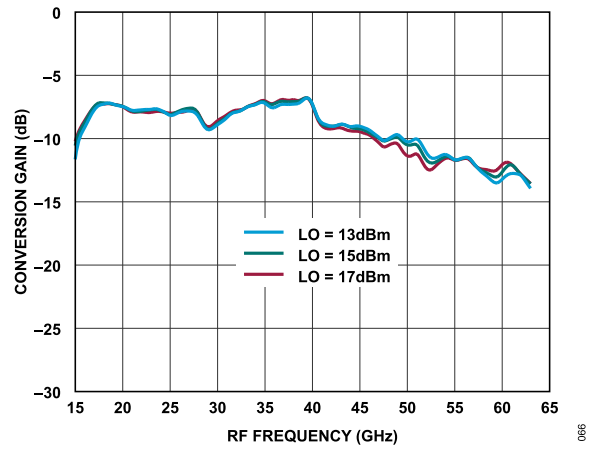

Figure 66. Conversion Gain vs. RF Frequency at Various LO Power Levels, $T_A = 25^\circ\text{C}$

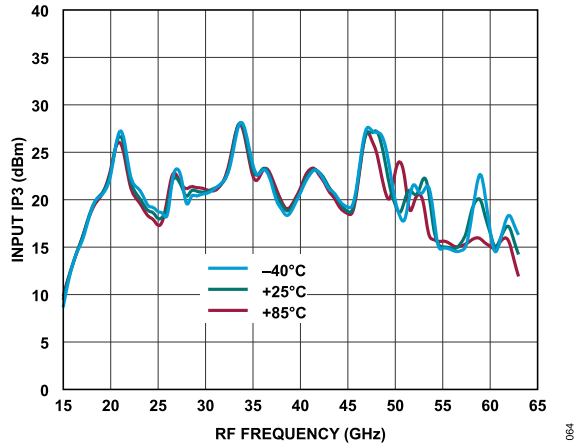

Figure 64. Input IP3 vs. RF Frequency at Various Temperatures, LO = 15 dBm

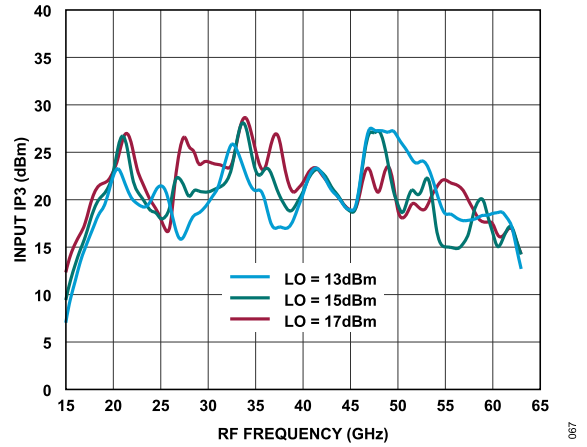

Figure 67. Input IP3 vs. RF Frequency at Various LO Power Levels, $T_A = 25^\circ\text{C}$

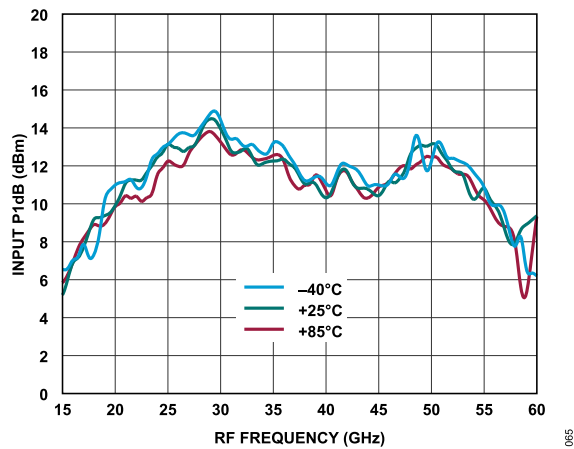

Figure 65. Input P1dB vs. RF Frequency at Various Temperatures, LO = 15 dBm

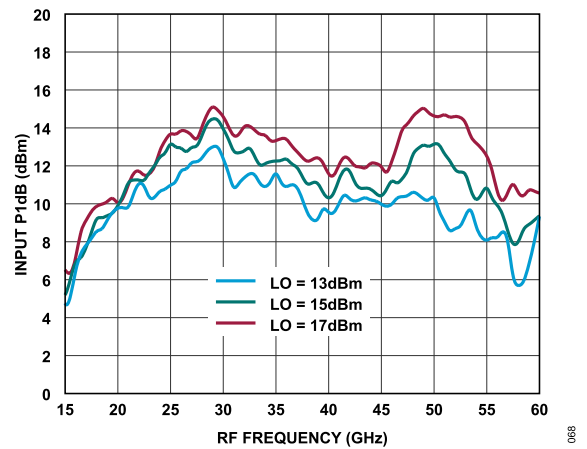

Figure 68. Input P1dB vs. RF Frequency at Various LO Power Levels, $T_A = 25^\circ\text{C}$

TYPICAL PERFORMANCE CHARACTERISTICS

UPCONVERTER PERFORMANCE, IF = 10 GHz

Upper Sideband (Low-Side LO)

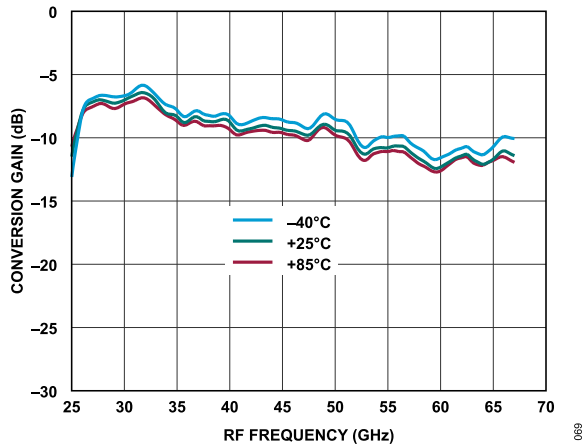

Figure 69. Conversion Gain vs. RF Frequency at Various Temperatures, LO = 15 dBm

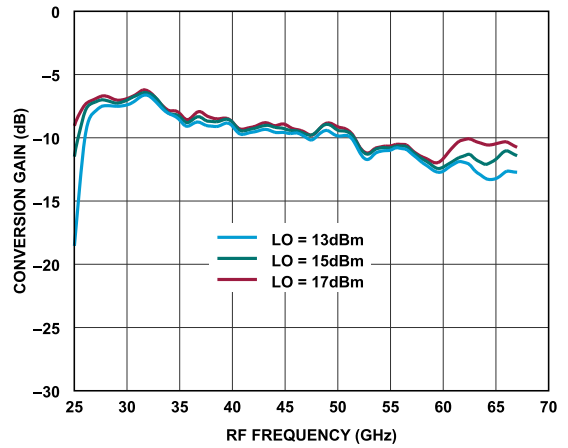

Figure 72. Conversion Gain vs. RF Frequency at Various LO Power Levels, $T_A = 25^\circ\text{C}$

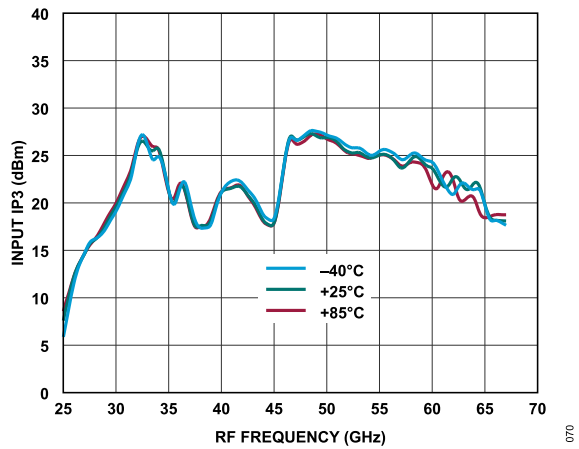

Figure 70. Input IP3 vs. RF Frequency at Various Temperatures, LO = 15 dBm

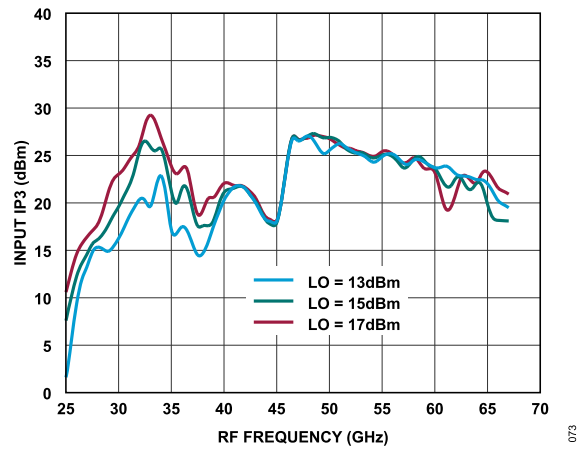

Figure 73. Input IP3 vs. RF Frequency at Various LO Power Levels, $T_A = 25^\circ\text{C}$

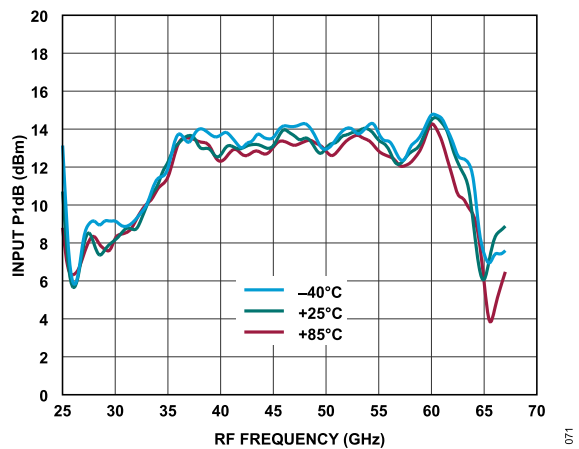

Figure 71. Input P1dB vs. RF Frequency at Various Temperatures, LO = 15 dBm

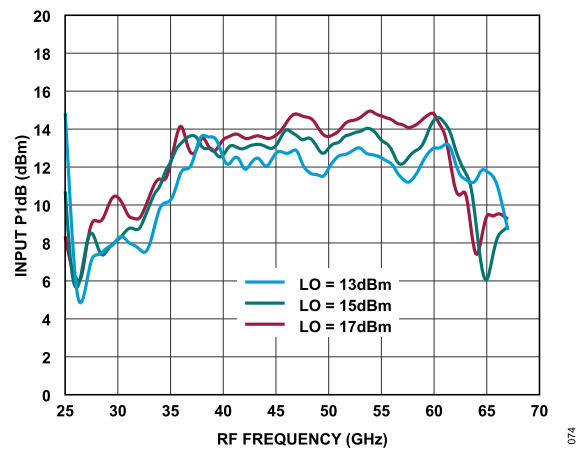

Figure 74. Input P1dB vs. RF Frequency at Various LO Power Levels, $T_A = 25^\circ\text{C}$

TYPICAL PERFORMANCE CHARACTERISTICS

Lower Sideband (High-Side LO)

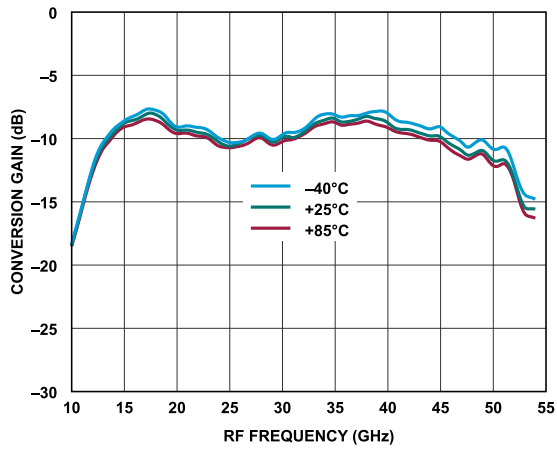

Figure 75. Conversion Gain vs. RF Frequency at Various Temperatures, LO = 15 dBm

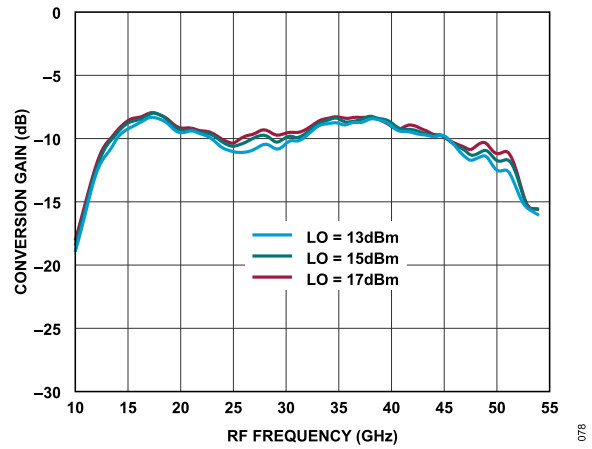

Figure 78. Conversion Gain vs. RF Frequency at Various LO Power Levels, $T_A = 25^\circ\text{C}$

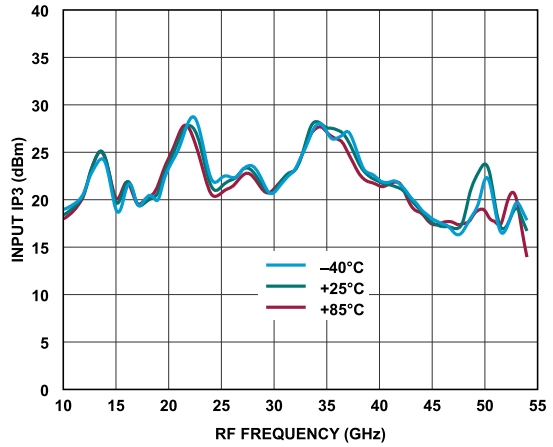

Figure 76. Input IP3 vs. RF Frequency at Various Temperatures, LO = 15 dBm

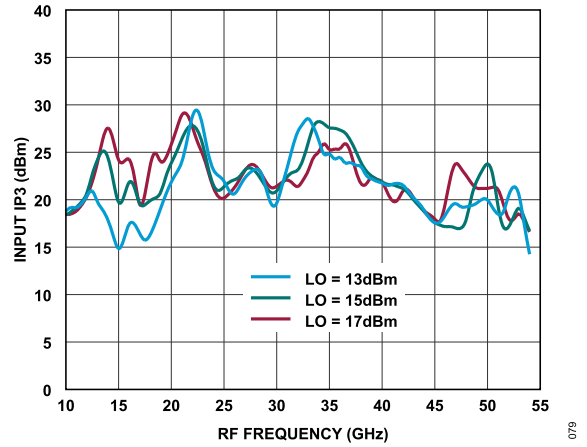

Figure 79. Input IP3 vs. RF Frequency at Various LO Power Levels, $T_A = 25^\circ\text{C}$

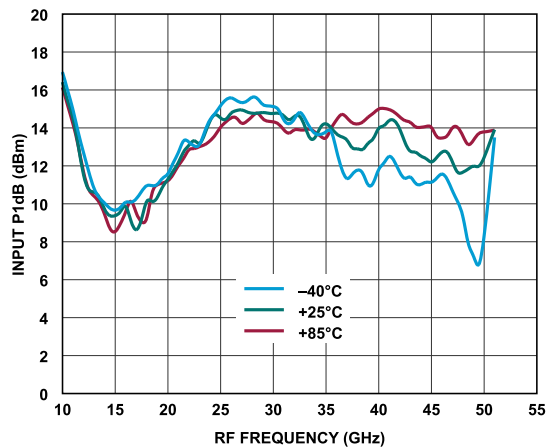

Figure 77. Input P1dB vs. RF Frequency at Various Temperatures, LO = 15 dBm

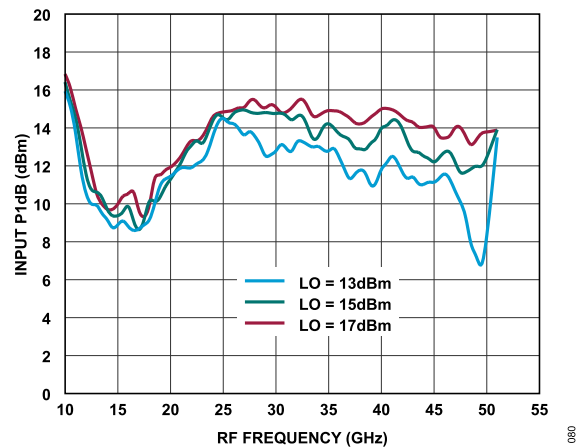

Figure 80. Input P1dB vs. RF Frequency at Various LO Power Levels, $T_A = 25^\circ\text{C}$

TYPICAL PERFORMANCE CHARACTERISTICS

UPCONVERTER PERFORMANCE, IF = 15 GHz

Upper Sideband (Low-Side LO)

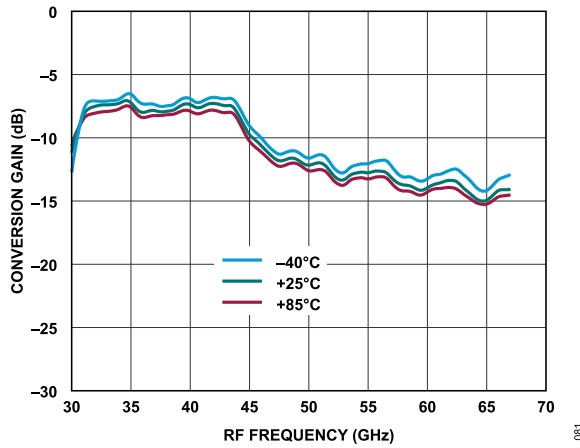

Figure 81. Conversion Gain vs. RF Frequency at Various Temperatures, LO = 15 dBm

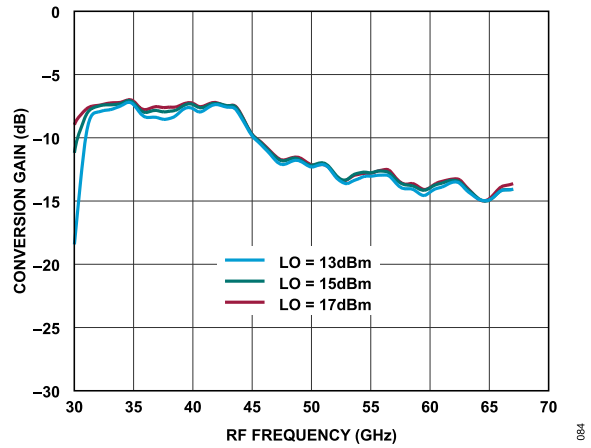

Figure 84. Conversion Gain vs. RF Frequency at Various LO Power Levels, $T_A = 25^\circ\text{C}$

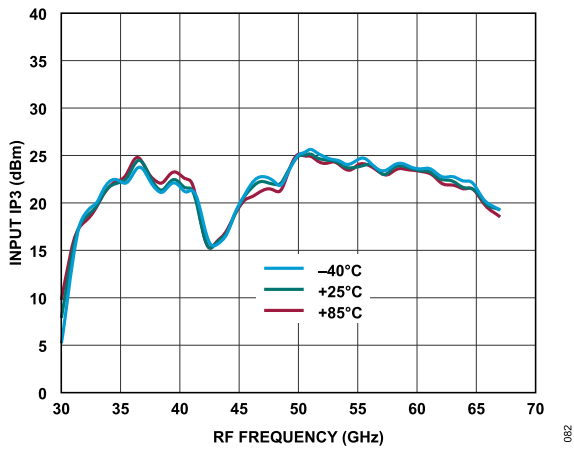

Figure 82. Input IP3 vs. RF Frequency at Various Temperatures, LO = 15 dBm

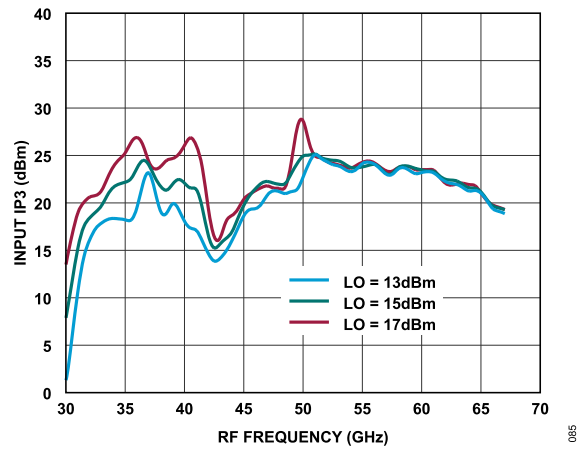

Figure 85. Input IP3 vs. RF Frequency at Various LO Power Levels, $T_A = 25^\circ\text{C}$

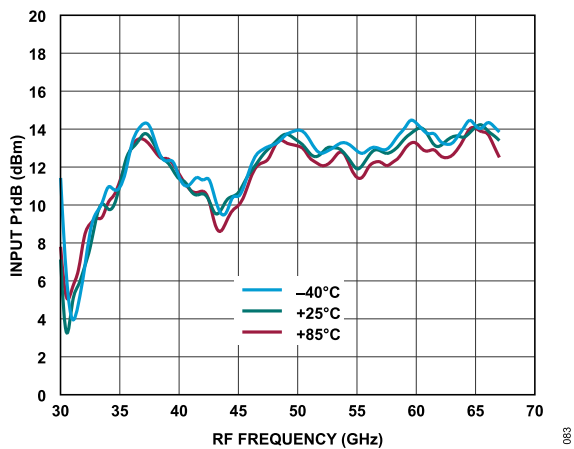

Figure 83. Input P1dB vs. RF Frequency at Various Temperatures, LO = 15 dBm

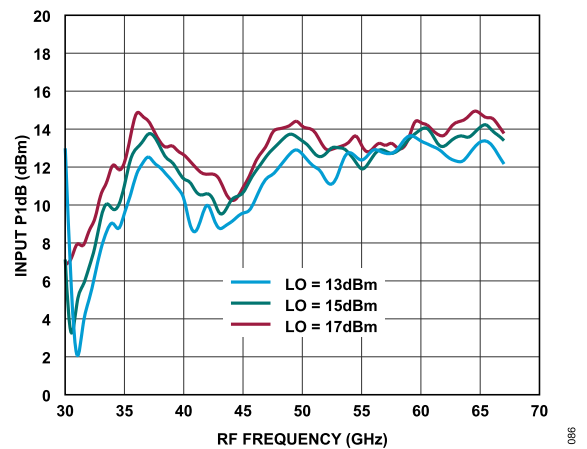

Figure 86. Input P1dB vs. RF Frequency at Various LO Power Levels, $T_A = 25^\circ\text{C}$

TYPICAL PERFORMANCE CHARACTERISTICS

Lower Sideband (High-Side LO)

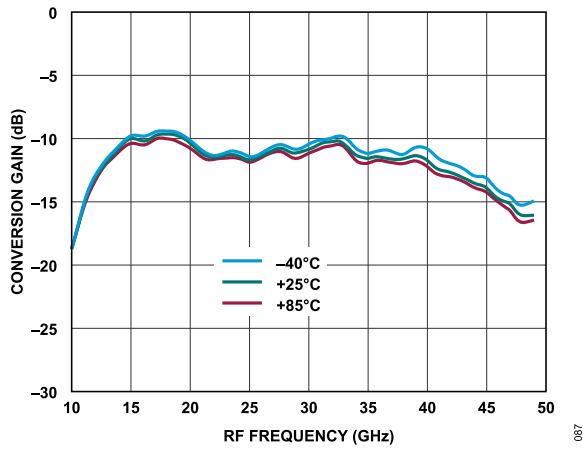

Figure 87. Conversion Gain vs. RF Frequency at Various Temperatures, LO = 15 dBm

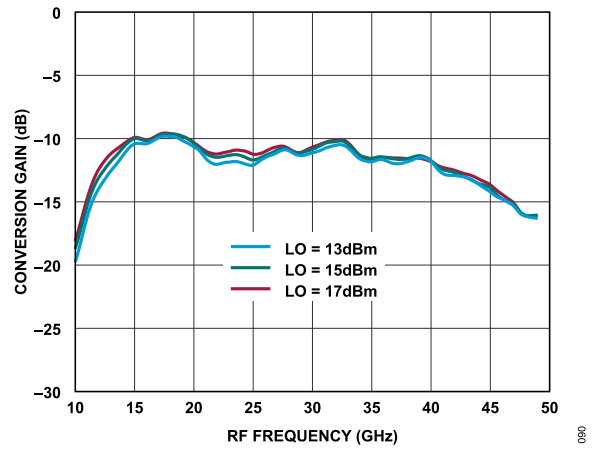

Figure 90. Conversion Gain vs. RF Frequency at Various LO Power Levels, TA = 25°C

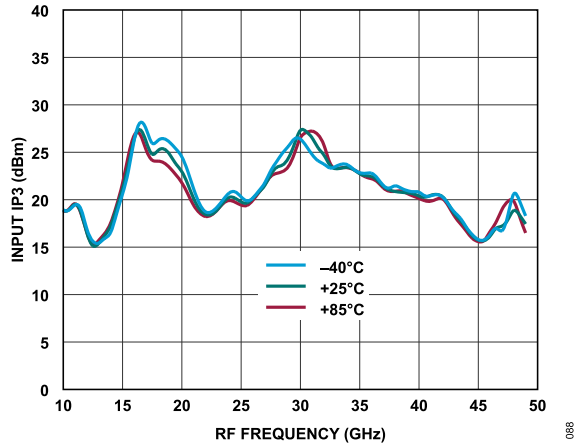

Figure 88. Input IP3 vs. RF Frequency at Various Temperatures, LO = 15 dBm

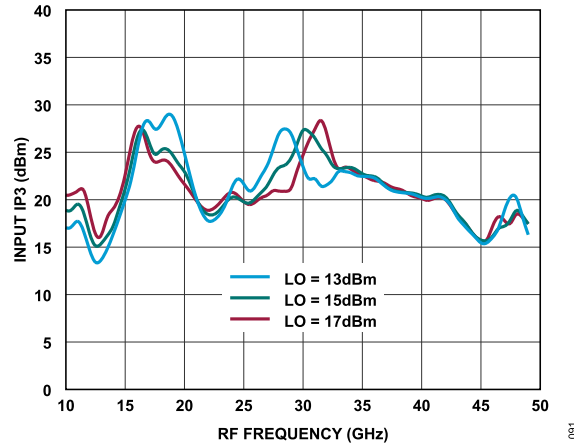

Figure 91. Input IP3 vs. RF Frequency at Various LO Power Levels, TA = 25°C

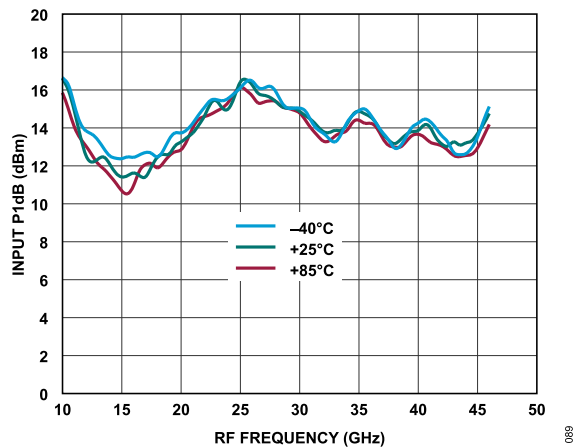

Figure 89. Input P1dB vs. RF Frequency at Various Temperatures, LO = 15 dBm

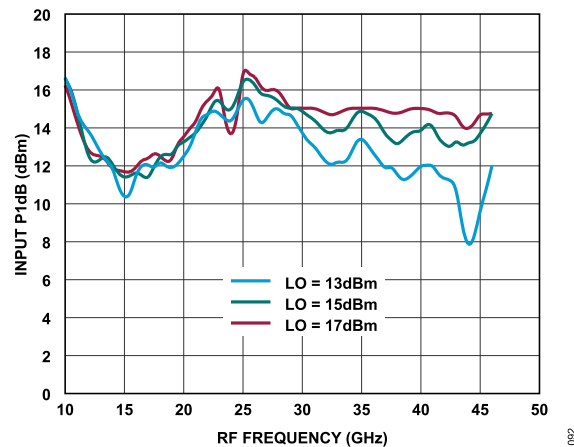

Figure 92. Input P1dB vs. RF Frequency at Various LO Power Levels, TA = 25°C

TYPICAL PERFORMANCE CHARACTERISTICS

ISOLATION AND RETURN LOSS

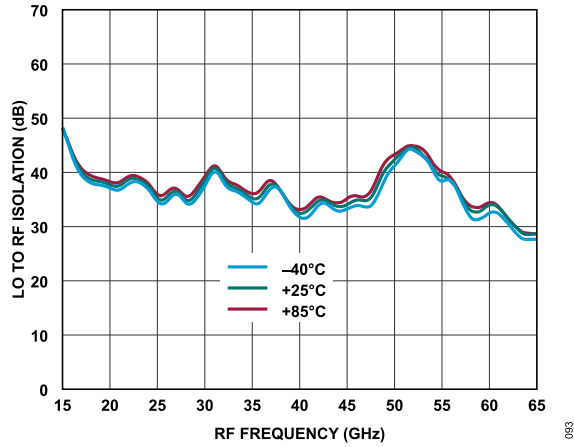

Figure 93. LO to RF Isolation vs. RF Frequency at Various Temperatures, LO = 15 dBm

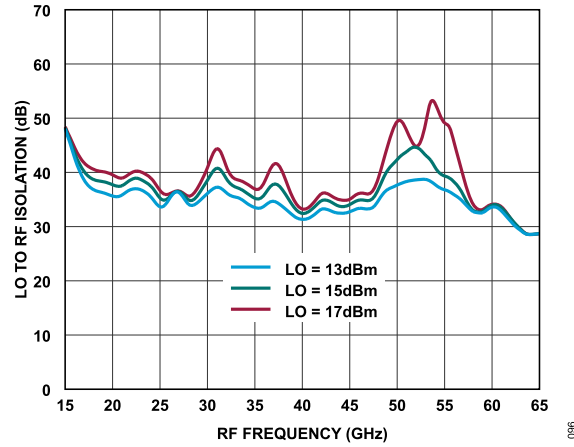

Figure 96. LO to RF Isolation vs. RF Frequency at Various LO Power Levels, TA = 25°C

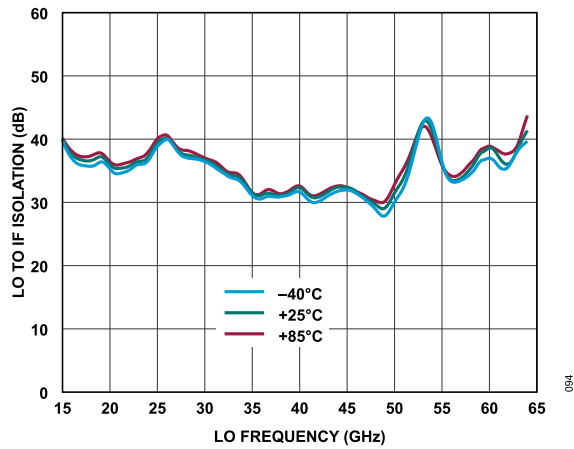

Figure 94. LO to IF Isolation vs. LO Frequency at Various Temperatures, LO = 15 dBm

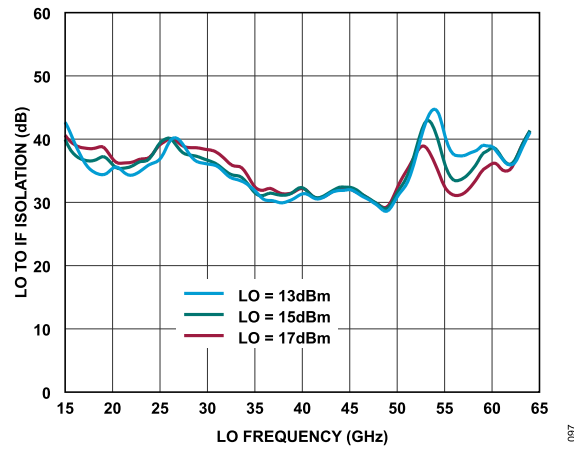

Figure 97. LO to IF Isolation vs. LO Frequency at Various LO Power Levels, TA = 25°C

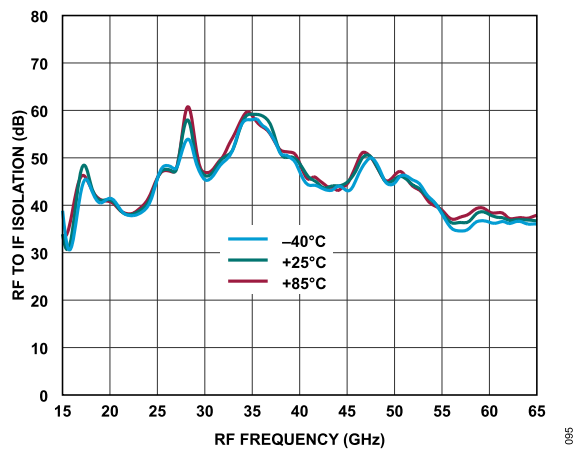

Figure 95. RF to IF Isolation vs. RF Frequency at Various Temperatures, LO = 15 dBm

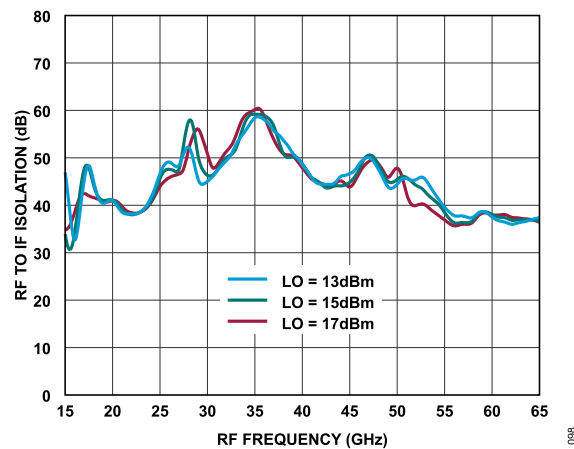

Figure 98. RF to IF Isolation vs. RF Frequency at Various LO Power Levels, TA = 25°C

TYPICAL PERFORMANCE CHARACTERISTICS

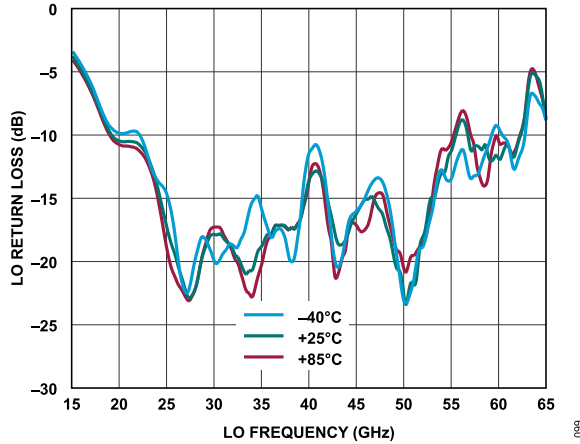

Figure 99. LO Return Loss vs. LO Frequency at Various Temperatures, LO = 15 dBm

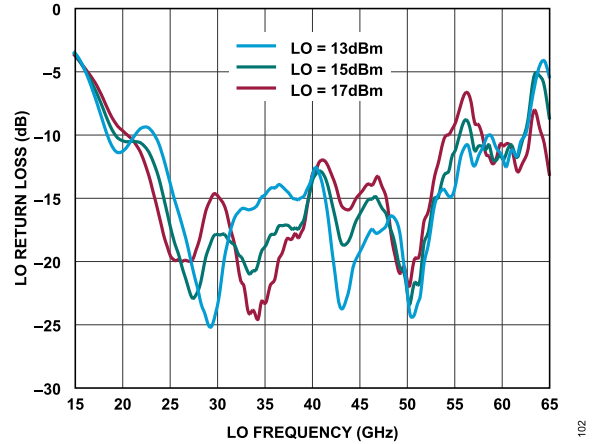

Figure 102. LO Return Loss vs. LO Frequency at Various LO Power Levels, $T_A = 25^\circ\text{C}$

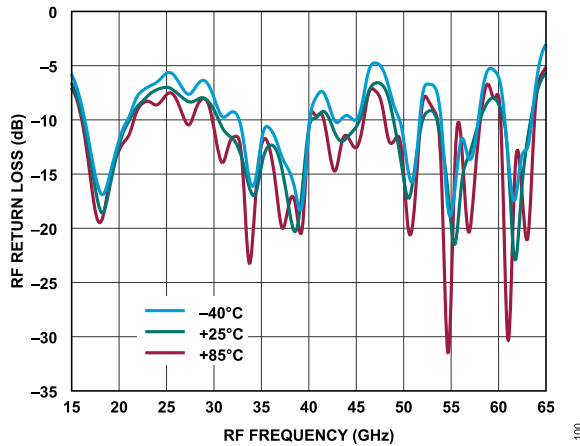

Figure 100. RF Return Loss vs. RF Frequency at Various Temperatures, LO = 15 dBm, LO = 40 GHz

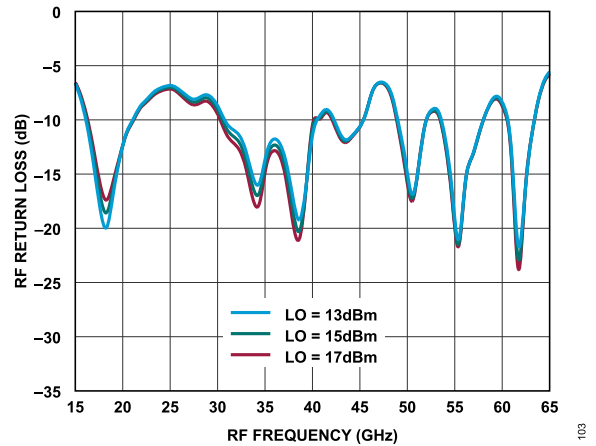

Figure 103. RF Return Loss vs. RF Frequency at Various LO Power Levels, $T_A = 25^\circ\text{C}$, LO = 40 GHz

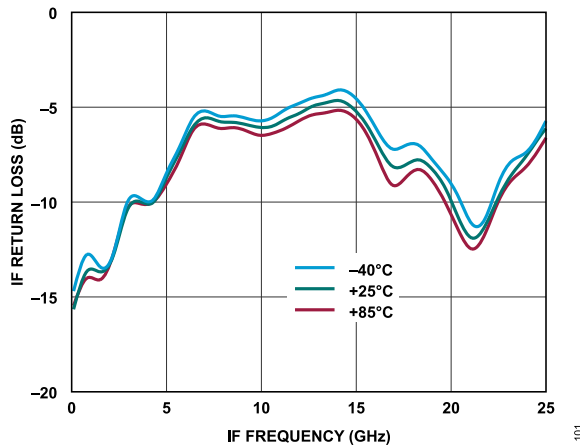

Figure 101. IF Return Loss vs. IF Frequency at Various Temperatures, LO = 15 dBm, LO = 40 GHz

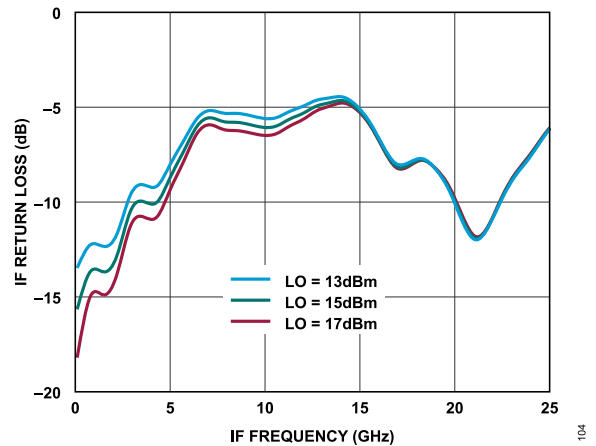

Figure 104. IF Return Loss vs. IF Frequency at Various LO Power Levels, $T_A = 25^\circ\text{C}$, LO = 40 GHz

TYPICAL PERFORMANCE CHARACTERISTICS

IF BANDWIDTH—DOWNCONVERTER

Upper Sideband, LO Frequency = 20 GHz

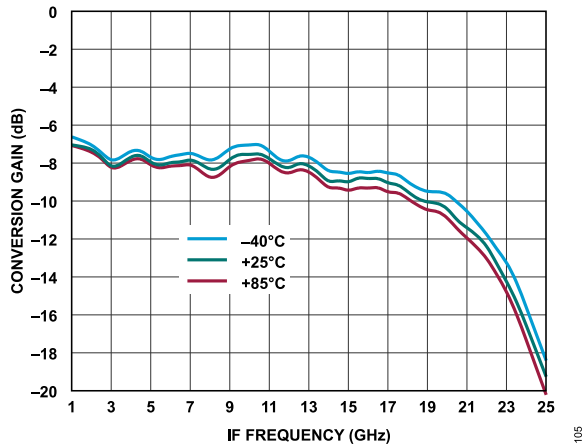

Figure 105. Conversion Gain vs. IF Frequency at Various Temperatures, LO = 15 dBm

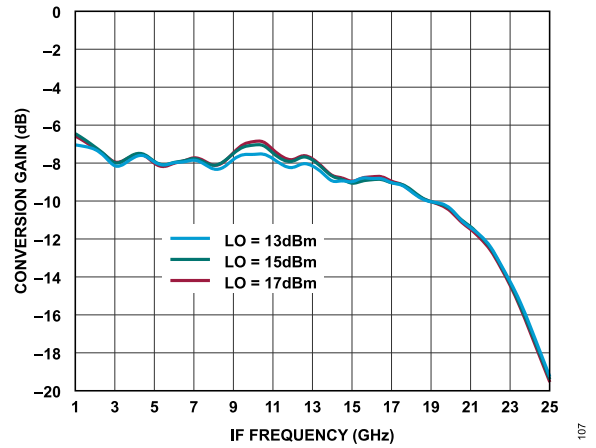

Figure 107. Conversion Gain vs. IF Frequency at Various LO Power Levels, $T_A = 25^\circ\text{C}$

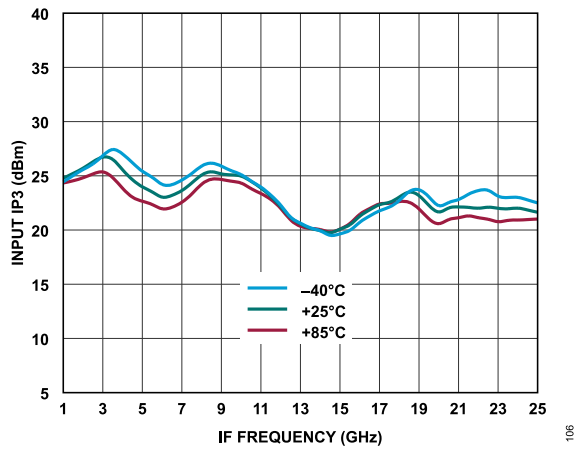

Figure 106. Input IP3 vs. IF Frequency at Various Temperatures, LO = 15 dBm

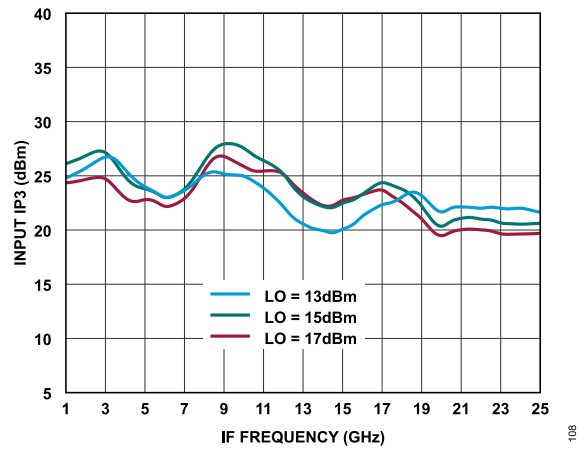

Figure 108. Input IP3 vs. IF Frequency at Various LO Power Levels, $T_A = 25^\circ\text{C}$

TYPICAL PERFORMANCE CHARACTERISTICS

Lower Sideband, LO Frequency = 60 GHz

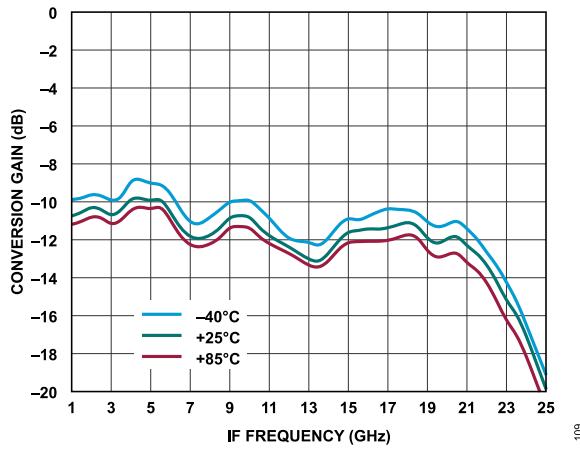

Figure 109. Conversion Gain vs. IF Frequency at Various Temperatures, LO = 15 dBm

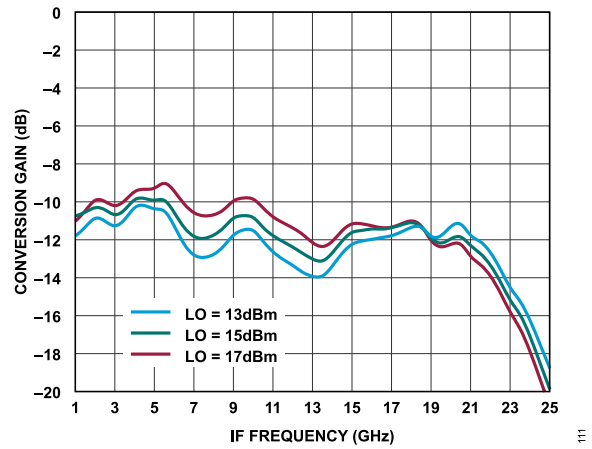

Figure 111. Conversion Gain vs. IF Frequency at Various LO Power Levels, $T_A = 25^\circ\text{C}$

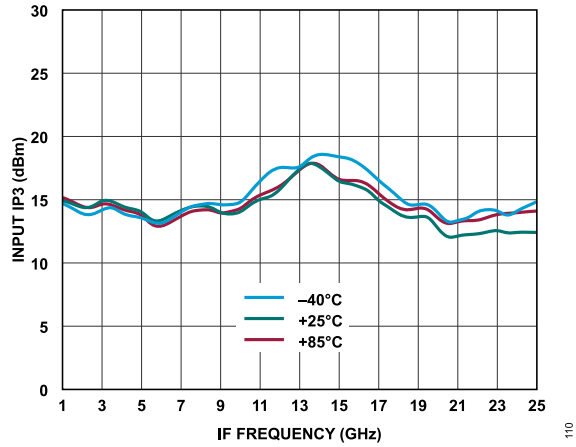

Figure 110. Input IP3 vs. IF Frequency at Various Temperatures, LO = 15 dBm

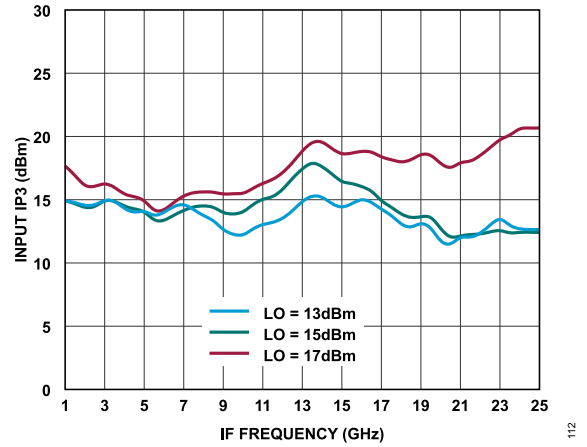

Figure 112. Input IP3 vs. IF Frequency at Various LO Power Levels, $T_A = 25^\circ\text{C}$

TYPICAL PERFORMANCE CHARACTERISTICS

IF BANDWIDTH—UPCONVERTER

Upper Sideband, LO Frequency = 20 GHz

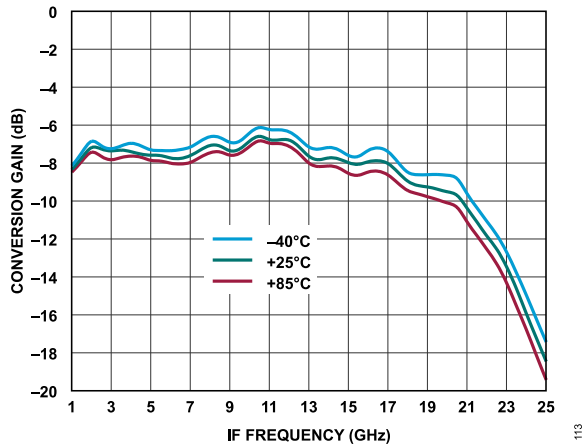

Figure 113. Conversion Gain vs. IF Frequency at Various Temperatures, LO = 15 dBm

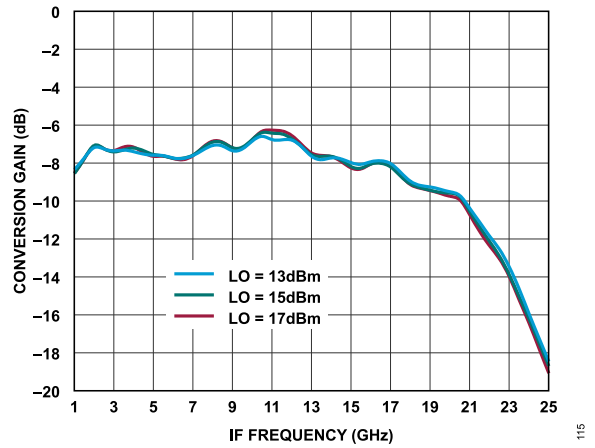

Figure 115. Conversion Gain vs. IF Frequency at Various LO Power Levels, $T_A = 25^\circ\text{C}$

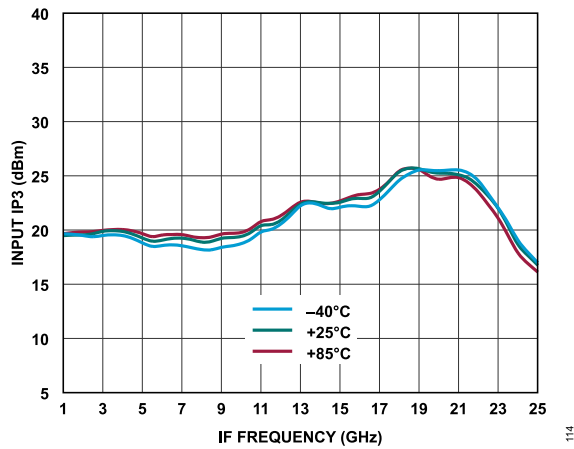

Figure 114. Input IP3 vs. IF Frequency at Various Temperatures, LO = 15 dBm

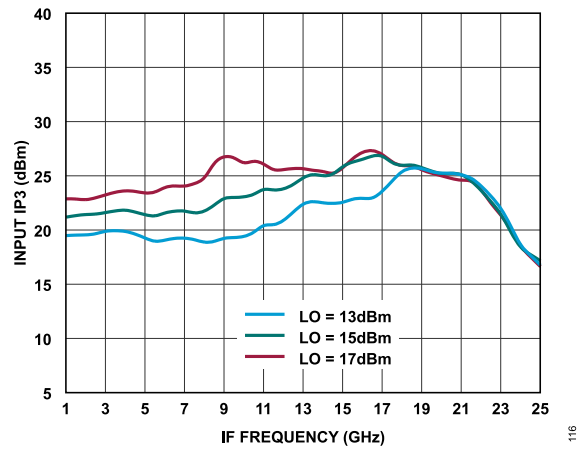

Figure 116. Input IP3 vs. IF Frequency at Various LO Power Levels, $T_A = 25^\circ\text{C}$

TYPICAL PERFORMANCE CHARACTERISTICS

Lower Sideband, LO Frequency = 50 GHz

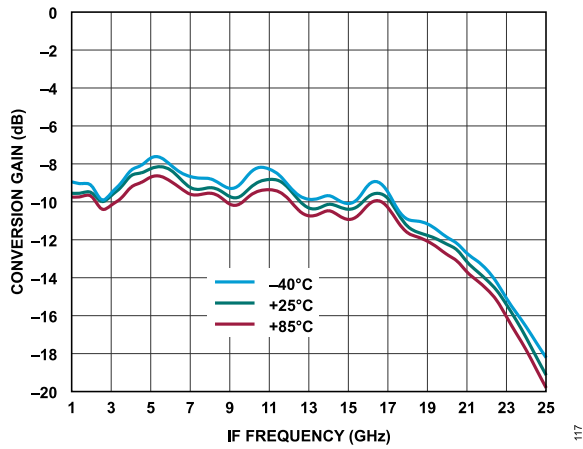

Figure 117. Conversion Gain vs. IF Frequency at Various Temperatures, LO = 15 dBm

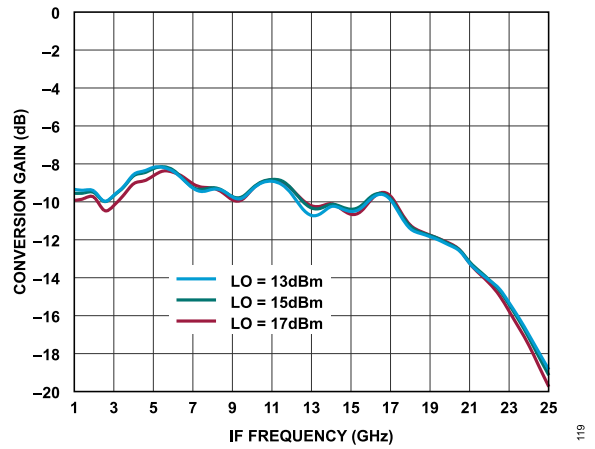

Figure 119. Conversion Gain vs. IF Frequency at Various LO Power Levels, $T_A = 25^\circ\text{C}$

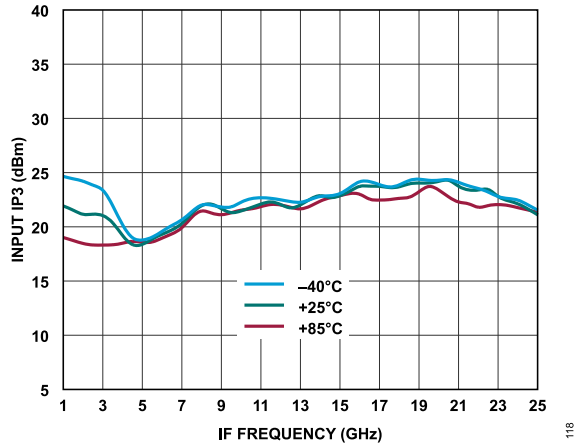

Figure 118. Input IP3 vs. IF Frequency at Various Temperatures, LO = 15 dBm

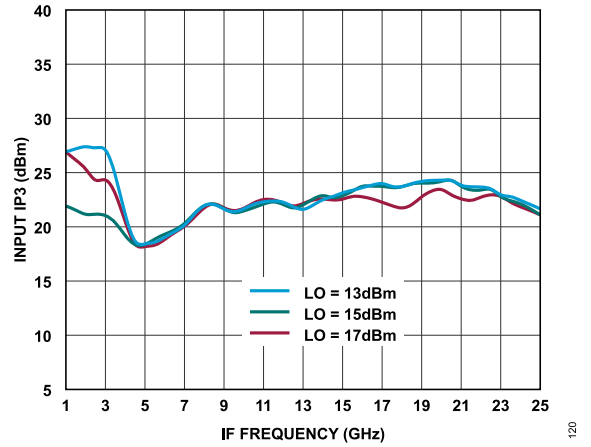

Figure 120. Input IP3 vs. IF Frequency at Various LO Power Levels, $T_A = 25^\circ\text{C}$

TYPICAL PERFORMANCE CHARACTERISTICS

M × N SPURIOUS OUTPUTS

Downconverter, Upper Sideband

Mixer spurious products are measured in dBc from the IF output power level. Spur values are (M × RF) – (N × LO). N/A means not applicable.

IF output (IF_{OUT}) = 1 GHz, RF input (RF_{IN}) = 21 GHz at -10 dBm, and LO = 20 GHz at +15 dBm.

		N × LO				
		0	1	2	3	4
M × RF	0	N/A	4	25	5	5
	1	31	0	35	46	48
	2	63	72	63	57	64
	3	61	61	71	71	73
	4	74	63	56	68	87

IF_{OUT} = 1 GHz, RF_{IN} = 31 GHz at -10 dBm, and LO = 30 GHz at +15 dBm.

		N × LO				
		0	1	2	3	4
M × RF	0	N/A	4	25	25	25
	1	40	0	45	32	32
	2	60	65	69	67	67
	3	68	61	67	87	70
	4	68	69	58	64	88

IF_{OUT} = 1 GHz, RF_{IN} = 41 GHz at -10 dBm, and LO = 40 GHz at +15 dBm.

		N × LO				
		0	1	2	3	4
M × RF	0	N/A	N/A	N/A	N/A	N/A
	1	38	0	58	58	59
	2	59	63	54	62	62
	3	62	61	62	67	64
	4	64	63	62	58	88

IF_{OUT} = 1 GHz, RF_{IN} = 60 GHz at -10 dBm, and LO = 60 GHz at +15 dBm.

		N × LO				
		0	1	2	3	4
M × RF	0	N/A	5	5	5	5
	1	28	0	43	43	43
	2	53	56	53	50	50
	3	50	50	62	53	67
	4	68	67	68	65	68

Downconverter, Lower Sideband

Mixer spurious products are measured in dBc from the IF output power level. Spur values are (M × RF) – (N × LO). N/A means not applicable.

IF output (IF_{OUT}) = 1 GHz, RF input (RF_{IN}) = 19 GHz at -10 dBm, and LO = 20 GHz at +15 dBm.

		N × LO				
		0	1	2	3	4
M × RF	0	N/A	5	25	25	25
	1	36	0	46	33	33
	2	69	66	68	67	60
	3	60	66	68	82	67
	4	66	68	64	70	86

IF_{OUT} = 1 GHz, RF_{IN} = 29 GHz at -10 dBm, and LO = 30 GHz at +15 dBm.

		N × LO				
		0	1	2	3	4
M × RF	0	N/A	1	4	4	4
	1	28	0	55	54	53
	2	53	57	48	56	53
	3	55	55	66	54	63
	4	62	64	63	63	69

IF_{OUT} = 1 GHz, RF_{IN} = 39 GHz at -10 dBm, and LO = 40 GHz at +15 dBm.

		N × LO				
		0	1	2	3	4
M × RF	0	N/A	N/A	N/A	N/A	N/A
	1	46	0	59	56	55
	2	60	62	56	62	61
	3	63	61	64	64	61
	4	60	57	59	63	89

IF_{OUT} = 1 GHz, RF_{IN} = 59 GHz at -10 dBm, and LO = 60 GHz at +15 dBm.

		N × LO				
		0	1	2	3	4
M × RF	0	N/A	4	4	4	4
	1	28	0	55	54	53
	2	53	57	48	56	53
	3	55	55	66	54	63
	4	62	64	63	63	69

TYPICAL PERFORMANCE CHARACTERISTICS

Upconverter, Upper Sideband

Mixer spurious products are measured in dBc from the RF output power level. Spur values are $(M \times IF) + (N \times LO)$. N/A means not applicable.

IF input (IF_{IN}) = 1 GHz, RF output (RF_{OUT}) = 21 GHz at -10 dBm, and LO = 20 GHz at +15 dBm.

		N × LO				
		0	1	2	3	4
M × IF	0	N/A	5	3	3	3
	1	55	0	41	11	11
	2	89	46	61	50	51
	3	89	73	63	65	65
	4	87	74	60	65	65

IF_{IN} = 1 GHz, RF_{OUT} = 31 GHz at -10 dBm, and LO = 30 GHz at +15 dBm.

		N × LO				
		0	1	2	3	4
M × IF	0	N/A	1	8	8	8
	1	55	0	18	18	18
	2	88	46	56	46	56
	3	90	68	66	67	66
	4	89	69	63	65	64

IF_{IN} = 1 GHz, RF_{OUT} = 41 GHz at -10 dBm, and LO = 40 GHz at +15 dBm.

		N × LO				
		0	1	2	3	4
M × IF	0	N/A	N/A	N/A	N/A	N/A
	1	56	0	N/A	N/A	N/A
	2	84	48	48	48	48
	3	87	62	63	64	64
	4	86	62	64	61	62

IF_{IN} = 1 GHz, RF_{OUT} = 61 GHz at -10 dBm, and LO = 60 GHz at +15 dBm.

		N × LO				
		0	1	2	3	4
M × IF	0	N/A	N/A	N/A	N/A	N/A
	1	54	0	N/A	N/A	N/A
	2	68	46	47	46	46
	3	85	39	39	39	40
	4	85	59	62	61	62

Upconverter, Lower Sideband

Mixer spurious products are measured in dBc from the RF output power level. Spur values are $(M \times IF) + (N \times LO)$. N/A means not applicable.

IF input (IF_{IN}) = 1 GHz, RF output (RF_{OUT}) = 19 GHz at -10 dBm, and LO = 20 GHz at +15 dBm.

		N × LO				
		0	1	2	3	4
M × IF	0	N/A	5	4	3	3
	1	54	0	41	12	12
	2	89	47	58	52	52
	3	90	72	64	65	67
	4	88	74	63	66	63

IF_{IN} = 1 GHz, RF_{OUT} = 29 GHz at -10 dBm, and LO = 30 GHz at +15 dBm.

		N × LO				
		0	1	2	3	4
M × IF	0	N/A	7	6	6	6
	1	52	0	17	17	17
	2	87	45	56	56	57
	3	86	66	63	63	65
	4	85	68	64	62	63

IF_{IN} = 1 GHz, RF_{OUT} = 39 GHz at -10 dBm, and LO = 40 GHz at +15 dBm.

		N × LO				
		0	1	2	3	4
M × IF	0	N/A	N/A	N/A	N/A	N/A
	1	57	0	N/A	N/A	N/A
	2	88	49	48	48	48
	3	89	63	63	64	64
	4	90	63	63	64	63

IF_{IN} = 1 GHz, RF_{OUT} = 59 GHz at -10 dBm, and LO = 60 GHz at +15 dBm.

		N × LO				
		0	1	2	3	4
M × IF	0	N/A	N/A	N/A	N/A	N/A
	1	53	0	N/A	N/A	N/A
	2	66	45	45	45	45
	3	82	38	38	38	38
	4	83	61	59	59	58

THEORY OF OPERATION

The ADMV1550 is a general-purpose, double balanced mixer that can be used as an upconverter or a downconverter from 15 GHz to 65 GHz.

When used as a downconverter, the ADMV1550 downconverts radio frequencies between 15 GHz and 65 GHz to intermediate frequencies between DC and 20 GHz.

When used as an upconverter, the mixer upconverts intermediate frequencies between DC and 20 GHz to radio frequencies between 15 GHz and 65 GHz.

APPLICATIONS INFORMATION

TYPICAL APPLICATION CIRCUIT

Figure 121 shows the typical application circuit for the ADMV1550. The ADMV1550 is a passive device that does not require any external components. The LO and RF pins are internally AC-coupled. The IF pin is internally DC-coupled. For applications not requiring operation to DC, DC block this port externally using a series capacitor of a value chosen to pass the necessary IF frequency range. When IF operation to DC is required, do not exceed the IF source and sink current ratings specified in the Absolute Maximum Ratings section.

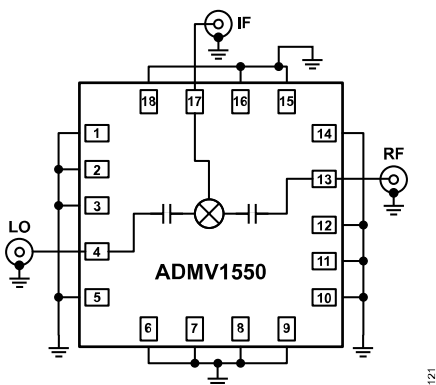

Figure 121. Typical Application Circuit

EVALUATION PCB INFORMATION

The circuit board used in the application must use RF circuit design techniques. Signal lines must have 50 Ω impedance, and the package grounds leads and exposed pad must be connected directly to the ground plane similarly to that shown in Figure 122. Use a sufficient number of via holes to connect the top and bottom ground planes. The evaluation circuit board shown in Figure 122 is available from Analog Devices, Inc., upon request.

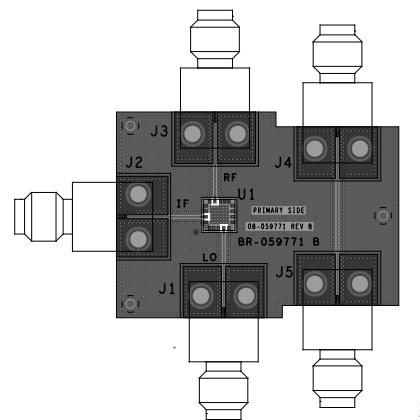

Figure 122. Evaluation PCB Top Layer

Table 7. Bill of Materials for the ADMV1530-EVALZ Evaluation PCB

Quantity	Reference Designator	Description	Manufacturer	Part Number
1		PCB, evaluation board		08-059771
5	J1 to J5	Connectors, 1.85 mm, 67 GHz	Southwest Microwave	1892-04-9
1	U1	Device under test (DUT)	Analog Devices	ADMV1550ACCZ

OUTLINE DIMENSIONS

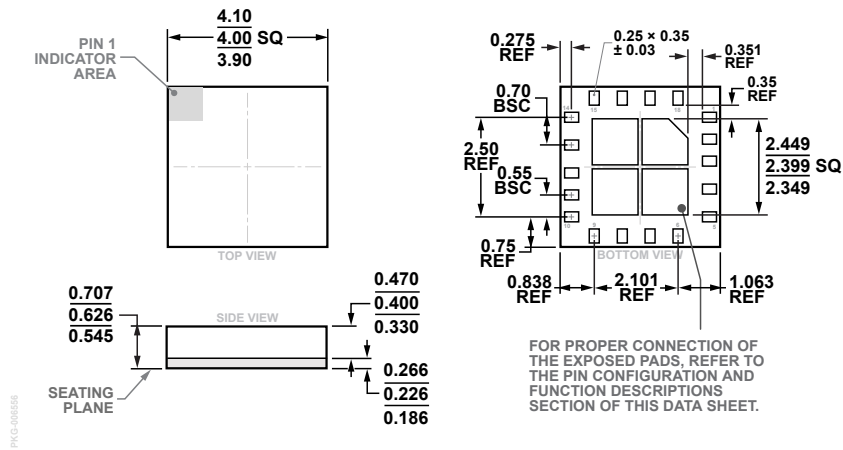

Figure 123. 18-Terminal Land Grid Array [LGA]
(CC-18-2)
Dimensions shown in millimeters

Updated: August 09, 2023

ORDERING GUIDE

Model ¹	Temperature Range	Package Description	Packing Quantity	Package Option
ADMV1550ACCZ	-40°C to +85°C	18-Terminal Land Grid Array [LGA]		CC-18-2
ADMV1550ACCZ-R2	-40°C to +85°C	18-Terminal Land Grid Array [LGA]	Reel, 250	CC-18-2

¹ Z = RoHS Compliant Part.

EVALUATION BOARDS

Table 8. Evaluation Boards

Model ¹	Description
ADMV1550-EVALZ	Evaluation Board

¹ Z = RoHS-Compliant Part.