

8-Channel Multicell Battery Monitor

FEATURES

- ▶ Measures up to 8 battery cells in series
- ▶ Maximum lifetime total measurement error: ± 1.9 mV at 3.3 V per cell (-40°C to $+85^{\circ}\text{C}$)
- ▶ Stackable architecture for high voltage battery packs
- ▶ Built-in isoSPI interface
 - ▶ 2 Mbps isolated serial communications
 - ▶ Uses a single twisted pair, up to 20 meters
 - ▶ Low EMI susceptibility and emissions
 - ▶ Bidirectional for broken wire protection
 - ▶ Capacitor or transformer coupled
- ▶ Hot plug tolerant without external protection
- ▶ Diagnostics for IC and application circuit failure modes
- ▶ 304 μs to measure all cells in a system
- ▶ 16-bit ADC with programmable noise filter
- ▶ Passive cell balancing up to 300 mA per channel with programmable PWM
- ▶ 7 GPIOx or analog inputs
 - ▶ Temperature or other sensor inputs
 - ▶ Configurable as an I²C or SPI controller
- ▶ Sleep state V+ supply current: 5.5 μA typical
- ▶ Cell and temperature monitoring in key-off state (LPCM)
- ▶ 48-lead LFCSP_SS package with exposed pad
- ▶ AEC-Q100 qualified for automotive applications

APPLICATIONS

- ▶ Electric and hybrid electric vehicles
- ▶ Backup battery systems
- ▶ Grid energy storage
- ▶ Large portable power banks

TYPICAL APPLICATION CIRCUIT

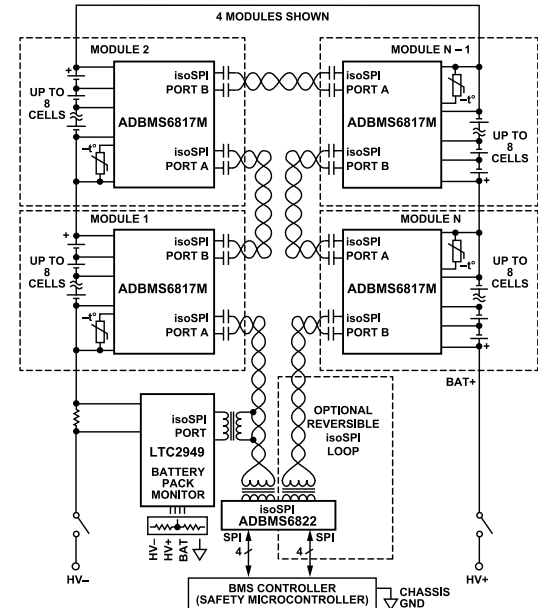

Figure 1. Typical Application Circuit

GENERAL DESCRIPTION

The ADBMS6817M is a multicell battery stack monitor that measures up to eight series connected battery cells with a lifetime total measurement error (TME) of less than 1.9 mV. The cell measurement range of 0 V to 5 V makes the ADBMS6817M suitable for most battery chemistries. All eight cells can be measured in 304 μs , and lower data acquisition rates can be selected for high noise reduction.

Multiple ADBMS6817M devices can be connected in series, permitting simultaneous cell monitoring of long, high voltage battery strings. Each ADBMS6817M has an isolated serial peripheral interface (isoSPI™) interface for high speed, RF immune, long distance communications. Multiple devices are connected in a daisy chain with one host processor connection for all devices. This daisy chain can operate bidirectionally to ensure communication integrity even in the event of a fault along the communication path.

The ADBMS6817M can be powered directly from the battery stack or from an isolated supply. The ADBMS6817M includes passive balancing for each cell, with individual pulse-width modulation (PWM) duty cycle control for each cell. Other features include an on-board 5 V regulator, seven general-purpose input and output (GPIOx) lines, and a sleep state, where current consumption is reduced to 5.5 μA .

For more information about the ADBMS6817M, contact BMS_Doc_Request@analog.com.

NOTES

www.datasheetall.com



©2022 Analog Devices, Inc. All rights reserved. Trademarks and registered trademarks are the property of their respective owners.
One Analog Way, Wilmington, MA 01887-2356, U.S.A.

Rev. Sp0 | 2 of 2